



Catalyst 2960-X and 2960-XR Switch Hardware Installation Guide

First Published: August 05, 2013

Last Modified: April 29, 2014

Americas Headquarters

Cisco Systems, Inc.
170 West Tasman Drive
San Jose, CA 95134-1706
USA
<http://www.cisco.com>
Tel: 408 526-4000
800 553-NETS (6387)
Fax: 408 527-0883

Text Part Number: OL-28309-02

THE SPECIFICATIONS AND INFORMATION REGARDING THE PRODUCTS IN THIS MANUAL ARE SUBJECT TO CHANGE WITHOUT NOTICE. ALL STATEMENTS, INFORMATION, AND RECOMMENDATIONS IN THIS MANUAL ARE BELIEVED TO BE ACCURATE BUT ARE PRESENTED WITHOUT WARRANTY OF ANY KIND, EXPRESS OR IMPLIED. USERS MUST TAKE FULL RESPONSIBILITY FOR THEIR APPLICATION OF ANY PRODUCTS.

THE SOFTWARE LICENSE AND LIMITED WARRANTY FOR THE ACCOMPANYING PRODUCT ARE SET FORTH IN THE INFORMATION PACKET THAT SHIPPED WITH THE PRODUCT AND ARE INCORPORATED HEREIN BY THIS REFERENCE. IF YOU ARE UNABLE TO LOCATE THE SOFTWARE LICENSE OR LIMITED WARRANTY, CONTACT YOUR CISCO REPRESENTATIVE FOR A COPY.

The following information is for FCC compliance of Class A devices: This equipment has been tested and found to comply with the limits for a Class A digital device, pursuant to part 15 of the FCC rules. These limits are designed to provide reasonable protection against harmful interference when the equipment is operated in a commercial environment. This equipment generates, uses, and can radiate radio-frequency energy and, if not installed and used in accordance with the instruction manual, may cause harmful interference to radio communications. Operation of this equipment in a residential area is likely to cause harmful interference, in which case users will be required to correct the interference at their own expense.

The following information is for FCC compliance of Class B devices: This equipment has been tested and found to comply with the limits for a Class B digital device, pursuant to part 15 of the FCC rules. These limits are designed to provide reasonable protection against harmful interference in a residential installation. This equipment generates, uses and can radiate radio frequency energy and, if not installed and used in accordance with the instructions, may cause harmful interference to radio communications. However, there is no guarantee that interference will not occur in a particular installation. If the equipment causes interference to radio or television reception, which can be determined by turning the equipment off and on, users are encouraged to try to correct the interference by using one or more of the following measures:

- Reorient or relocate the receiving antenna.
- Increase the separation between the equipment and receiver.
- Connect the equipment into an outlet on a circuit different from that to which the receiver is connected.
- Consult the dealer or an experienced radio/TV technician for help.

Modifications to this product not authorized by Cisco could void the FCC approval and negate your authority to operate the product

The Cisco implementation of TCP header compression is an adaptation of a program developed by the University of California, Berkeley (UCB) as part of UCB's public domain version of the UNIX operating system. All rights reserved. Copyright © 1981, Regents of the University of California.

NOTWITHSTANDING ANY OTHER WARRANTY HEREIN, ALL DOCUMENT FILES AND SOFTWARE OF THESE SUPPLIERS ARE PROVIDED "AS IS" WITH ALL FAULTS. CISCO AND THE ABOVE-NAMED SUPPLIERS DISCLAIM ALL WARRANTIES, EXPRESSED OR IMPLIED, INCLUDING, WITHOUT LIMITATION, THOSE OF MERCHANTABILITY, FITNESS FOR A PARTICULAR PURPOSE AND NONINFRINGEMENT OR ARISING FROM A COURSE OF DEALING, USAGE, OR TRADE PRACTICE.

IN NO EVENT SHALL CISCO OR ITS SUPPLIERS BE LIABLE FOR ANY INDIRECT, SPECIAL, CONSEQUENTIAL, OR INCIDENTAL DAMAGES, INCLUDING, WITHOUT LIMITATION, LOST PROFITS OR LOSS OR DAMAGE TO DATA ARISING OUT OF THE USE OR INABILITY TO USE THIS MANUAL, EVEN IF CISCO OR ITS SUPPLIERS HAVE BEEN ADVISED OF THE POSSIBILITY OF SUCH DAMAGES.

Any Internet Protocol (IP) addresses and phone numbers used in this document are not intended to be actual addresses and phone numbers. Any examples, command display output, network topology diagrams, and other figures included in the document are shown for illustrative purposes only. Any use of actual IP addresses or phone numbers in illustrative content is unintentional and coincidental.

Cisco and the Cisco logo are trademarks or registered trademarks of Cisco and/or its affiliates in the U.S. and other countries. To view a list of Cisco trademarks, go to this URL: <http://www.cisco.com/go/trademarks>. Third-party trademarks mentioned are the property of their respective owners. The use of the word partner does not imply a partnership relationship between Cisco and any other company. (1110R)

© 2013, 2014 Cisco Systems, Inc. All rights reserved.



CONTENTS

Preface

Preface vii

Document Conventions vii

Related Documentation ix

Obtaining Documentation and Submitting a Service Request ix

CHAPTER 1

Product Overview 1

Switch Models 1

Front Panel 3

PoE and PoE+ Ports 5

10/100/1000 Ports 5

Management Ports 6

USB Type A Port 7

SFP and SFP+ Module Slots 7

LEDs 7

System LED 10

RPS LED 10

IRPS LED 11

Master LED 11

Port LEDs and Modes 11

STACK LED 14

Console LEDs 15

Ethernet Management Port LED 15

Rear Panel 15

FlexStack-Plus Ports and LEDs 17

RPS Connector 18

Cisco RPS 2300 18

AC Power Connector 19

Power Supply Modules (Applies to the Catalyst 2960-XR Switches)	19
Management Options	20
Network Configurations	21

CHAPTER 2**Switch Installation 23**

Safety Warnings	23
Box Contents	26
Tools and Equipment	26
Installation Guidelines	26
Verifying Switch Operation	27
Planning and Installing a Switch Stack (Optional)	28
Stack Guidelines	28
Installing the FlexStack-Plus Module	29
Stack Cabling	31
Stack Bandwidth and Partitioning Examples	32
Power-On Sequence for Switch Stacks	33
Installing the Switch	33
Rack-Mounting	33
Attaching the Rack-Mount Brackets for the Catalyst 2960-X Switches	35
Attaching the Rack-Mount Brackets for the Catalyst 2960-XR Switches	36
Mounting in a Rack	37
Wall-Mounting	38
Attaching the Brackets for Wall-Mounting	38
Attaching the RPS Connector Cover	39
Mounting on a Wall	40
Installing the Switch on a Table or Shelf	41
After Switch Installation	41
Connecting the FlexStack Cables (Optional)	41
Removing a FlexStack Cable	42
Installing the Power Cord Retainer (Optional)	43
Installing SFP and SFP+ Modules	45
Installing an SFP or SFP+ Module	46
Removing an SFP or SFP+ Module	47
Connecting to SFP and SFP+ Modules	47
Connecting to Fiber-Optic SFP and SFP+ Modules	48

Connecting to 1000BASE-T SFP	49
10/100/1000 PoE+ Port Connections	50
10/100/1000 Port Connections	51
Auto-MDIX Connections	51
Where to Go Next	52

CHAPTER 3**Power Supply Installation 53**

Power Supply Module Overview	53
Installation Guidelines	56
Installing or Replacing an AC Power Supply	57
Finding the Serial Number	59

CHAPTER 4**Troubleshooting 61**

Diagnosing Problems	61
Switch POST Results	61
Switch LEDs	61
Switch Connections	62
Bad or Damaged Cable	62
Ethernet and Fiber-Optic Cables	62
Link Status	62
10/100/1000 Port Connections	63
10/100/1000 PoE+ Port Connections	63
SFP and SFP+ Module	63
Interface Settings	64
Ping End Device	64
Spanning Tree Loops	64
Switch Performance	64
Speed, Duplex, and Autonegotiation	64
Autonegotiation and Network Interface Cards	64
Cabling Distance	65
Clearing the Switch IP Address and Configuration	65
Finding the Serial Number	66
Replacing a Failed Stack Member	67

APPENDIX A**Technical Specifications 69**

Environmental Specifications	69
Specifications for the Catalyst 2960-X Switches	70
Specifications for the Catalyst 2960-XR Switches	74

APPENDIX B**Connector and Cable Specifications 77**

Connector Specifications	77
10/100/1000 Ports (Including PoE)	77
SFP Module Connectors	78
Cables and Adapters	78
SFP Module Cables	78
Cable Pinouts	80
Console Port Adapter Pinouts	81

APPENDIX C**Configuring the Switch with the CLI-Based Setup Program 83**

Accessing the CLI Through Express Setup	83
Accessing the CLI Through the Console Port	83
Connecting the RJ-45 Console Port	84
Connecting the USB Console Port	85
Installing the Cisco Microsoft Windows USB Device Driver	86
Installing the Cisco Microsoft Windows XP USB Driver	86
Installing the Cisco Microsoft Windows 2000 USB Driver	87
Installing the Cisco Microsoft Windows Vista and Windows 7 USB Driver	87
Uninstalling the Cisco Microsoft Windows USB Driver	87
Uninstalling the Cisco Microsoft Windows XP and 2000 USB Driver	87
Using the Setup.exe Program	88
Using the Add or Remove Programs Utility	88
Uninstalling the Cisco Microsoft Windows Vista and Windows 7 USB Driver	88
Entering the Initial Configuration Information	89
IP Settings	89
Completing the Setup Program	89



Preface

- [Document Conventions](#), page vii
- [Related Documentation](#), page ix
- [Obtaining Documentation and Submitting a Service Request](#), page ix

Document Conventions

This document uses the following conventions:

Convention	Description
<code>^</code> or <code>Ctrl</code>	Both the <code>^</code> symbol and <code>Ctrl</code> represent the Control (Ctrl) key on a keyboard. For example, the key combination <code>^D</code> or <code>Ctrl-D</code> means that you hold down the Control key while you press the D key. (Keys are indicated in capital letters but are not case sensitive.)
bold font	Commands and keywords and user-entered text appear in bold font .
<i>Italic font</i>	Document titles, new or emphasized terms, and arguments for which you supply values are in <i>italic font</i> .
<code>Courier font</code>	Terminal sessions and information the system displays appear in <code>courier font</code> .
Bold Courier font	Bold Courier font indicates text that the user must enter.
[x]	Elements in square brackets are optional.
...	An ellipsis (three consecutive nonbolded periods without spaces) after a syntax element indicates that the element can be repeated.
	A vertical line, called a pipe, indicates a choice within a set of keywords or arguments.
[x y]	Optional alternative keywords are grouped in brackets and separated by vertical bars.

Convention	Description
{x y}	Required alternative keywords are grouped in braces and separated by vertical bars.
[x {y z}]	Nested set of square brackets or braces indicate optional or required choices within optional or required elements. Braces and a vertical bar within square brackets indicate a required choice within an optional element.
string	A nonquoted set of characters. Do not use quotation marks around the string or the string will include the quotation marks.
<>	Nonprinting characters such as passwords are in angle brackets.
[]	Default responses to system prompts are in square brackets.
!, #	An exclamation point (!) or a pound sign (#) at the beginning of a line of code indicates a comment line.

Reader Alert Conventions

This document may use the following conventions for reader alerts:



Note

Means *reader take note*. Notes contain helpful suggestions or references to material not covered in the manual.



Tip

Means *the following information will help you solve a problem*.



Caution

Means *reader be careful*. In this situation, you might do something that could result in equipment damage or loss of data.



Timesaver

Means *the described action saves time*. You can save time by performing the action described in the paragraph.



Warning

IMPORTANT SAFETY INSTRUCTIONS

This warning symbol means danger. You are in a situation that could cause bodily injury. Before you work on any equipment, be aware of the hazards involved with electrical circuitry and be familiar with standard practices for preventing accidents. Use the statement number provided at the end of each warning to locate its translation in the translated safety warnings that accompanied this device. Statement 1071

SAVE THESE INSTRUCTIONS

Related Documentation

**Note**

Before installing or upgrading the , refer to the release notes.

- Cisco Validated Designs documents, located at:

<http://www.cisco.com/go/designzone>

Obtaining Documentation and Submitting a Service Request

For information on obtaining documentation, submitting a service request, and gathering additional information, see the monthly *What's New in Cisco Product Documentation*, which also lists all new and revised Cisco technical documentation, at:

<http://www.cisco.com/c/en/us/td/docs/general/whatsnew/whatsnew.html>

Subscribe to the *What's New in Cisco Product Documentation* as a Really Simple Syndication (RSS) feed and set content to be delivered directly to your desktop using a reader application. The RSS feeds are a free service and Cisco currently supports RSS version 2.0.



Product Overview

The Catalyst 2960-X and Catalyst 2960-XR family of switches are Ethernet switches to which you can connect devices such as Cisco IP Phones, Cisco Wireless Access Points, workstations, and other network devices such as servers, routers, and other switches.

Some models of the switches support stacking through the Cisco FlexStack-Plus technology. Unless otherwise noted, the term *switch* refers to a standalone switch and to a switch stack.

This chapter contains these topics:

- [Switch Models, page 1](#)
- [Front Panel, page 3](#)
- [Rear Panel, page 15](#)
- [Management Options, page 20](#)
- [Network Configurations, page 21](#)

Switch Models

Table 1: Catalyst 2960-X Switch Models and Descriptions

Switch Model	Supported Software Image	Description
Catalyst 2960X-48FPD-L ¹	LAN Base	48 10/100/1000 Power over Ethernet Plus (PoE+) ports (PoE budget of 740 W) and 2 small form-factor pluggable (SFP)+ ² module slots.
Catalyst 2960X-48LPD-L ¹	LAN Base	48 10/100/1000 PoE+ ports (PoE budget of 370 W) and 2 SFP+ module slots.
Catalyst 2960X-24PD-L ¹	LAN Base	24 10/100/1000 PoE+ ports (PoE budget of 370 W) and 2 SFP+ module slots.

Switch Model	Supported Software Image	Description
Catalyst 2960X-48TD-L ¹	LAN Base	48 10/100/1000 ports and 2 SFP+ module slots.
Catalyst 2960X-24TD-L ¹	LAN Base	24 10/100/1000 ports and 2 SFP+ module slots.
Catalyst 2960X-48FPS-L ¹	LAN Base	48 10/100/1000 PoE+ ports (PoE budget of 740 W) and 4 SFP ³ module slots.
Catalyst 2960X-48LPS-L ¹	LAN Base	48 10/100/1000 PoE+ ports (PoE budget of 370 W) and 4 SFP module slots.
Catalyst 2960X-24PS-L ¹	LAN Base	24 10/100/1000 PoE+ ports (PoE budget of 370 W) and 4 SFP module slots.
Catalyst 2960X-48TS-L ¹	LAN Base	48 10/100/1000 ports and 4 SFP module slots.
Catalyst 2960X-24TS-L ¹	LAN Base	24 10/100/1000 ports and 4 SFP module slots
Catalyst 2960X-48TS-LL	LAN Lite	48 10/100/1000 ports and 2 SFP module slots.
Catalyst 2960X-24TS-LL	LAN Lite	24 10/100/1000 ports and 2 SFP module slots.
Catalyst 2960X-24PSQ-L	LAN Base	24 10/100/1000 (8 PoE- with PoE budget of 110 W) ports, fanless, 2 10/100/1000BaseT copper uplinks, and 2 SFP module slots.

¹ Support Cisco FlexStack-Plus technology.

² SFP+ = 10-Gigabit uplink.

³ SFP = 1-Gigabit uplink.

Table 2: Catalyst 2960-XR Switch Models and Descriptions

Switch Model	Supported Software Image	Description
Catalyst 2960XR-48FPD-I ¹	IP Lite	48 10/100/1000 PoE+ ports (PoE budget of 740 W) 2 SFP+ module slots, 1025-W power supply.
Catalyst 2960XR-48LPD-I ¹	IP Lite	48 10/100/1000 PoE+ ports (PoE budget of 370 W) 2 SFP+ module slots, 640-W power supply.
Catalyst 2960XR-24PD-I ¹	IP Lite	24 10/100/1000 PoE+ ports (PoE budget of 370 W) 2 SFP+ module slots, 640-W power supply.
Catalyst 2960XR-48TD-I ¹	IP Lite	48 10/100/1000 and 2 SFP+ module slots, 250-W power supply.

Switch Model	Supported Software Image	Description
Catalyst 2960XR-24TD-I ¹	IP Lite	24 10/100/1000 and 2 SFP+ module slots, 250-W power supply.
Catalyst 2960XR-48FPS-I ¹	IP Lite	48 10/100/1000 PoE+ ports (PoE budget of 740 W) and 4 SFP module slots, 1025-W power supply.
Catalyst 2960XR-48LPS-I ¹	IP Lite	48 10/100/1000 PoE+ ports (PoE budget of 370 W) and 4 SFP module slots, 640-W power supply.
Catalyst 2960XR-24PS-I ¹	IP Lite	24 10/100/1000 PoE+ ports (PoE budget of 370 W) and 4 SFP module slots, 640-W power supply.
Catalyst 2960XR-48TS-I ¹	IP Lite	48 10/100/1000 and 4 SFP module slots, 250-W power supply.
Catalyst 2960XR-24TS-I ¹	IP Lite	24 10/100/1000 and 4 SFP module slots, 250-W power supply.

Front Panel

This section describes the front panel components:

- 24 or 48 downlink ports of one of these types:
 - 10/100/1000
 - 10/100/1000 PoE+
- SFP ports
- USB Type A connectors
- USB mini-Type B (console) port
- Ethernet management port
- RJ-45 console port
- LEDs
- Mode button

The Catalyst 2960X-48FPD-L switch is shown here as an example. Other switches have similar components.

Figure 1: Catalyst 2960X-48FPD-L Front Panel

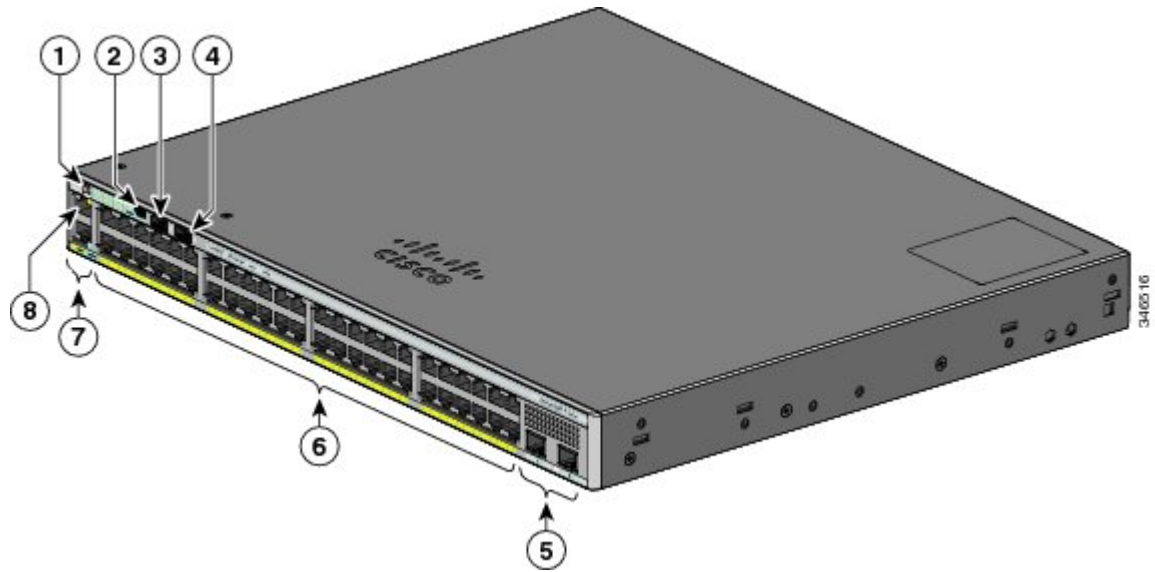

1	Mode button and switch LEDs	5	SFP module slots
2	USB mini-Type B (console) port	6	10/100/1000 PoE+ ports
3	USB Type A port	7	RJ-45 console port
4	USB Type A port	8	Ethernet management port

The Catalyst 2960XR-48LPD-I switch is shown here as an example. Other Catalyst 2960-XR switches have similar components.

Figure 2: Catalyst 2960XR-48LPD-I Front Panel

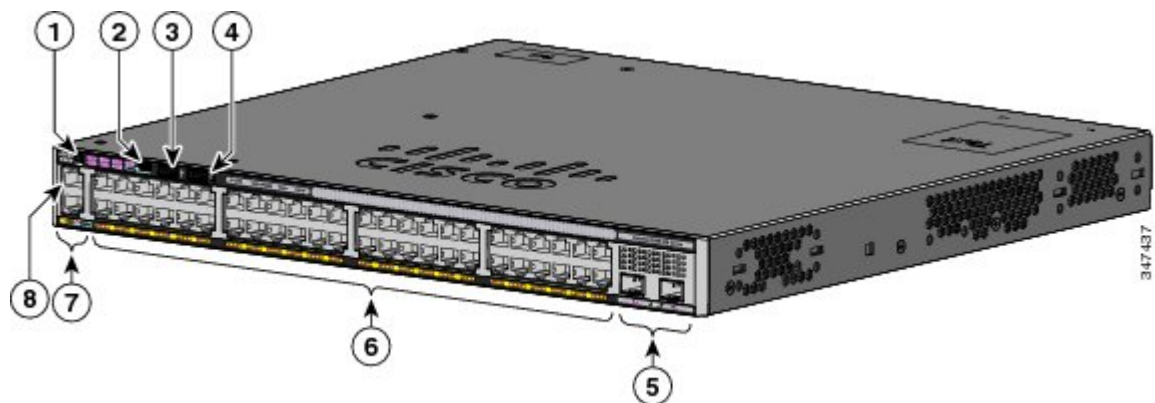

1	Mode button and switch LEDs	5	SFP+ module slots
---	-----------------------------	---	-------------------

2	USB mini-Type B (console) port	6	10/100/1000 PoE+ ports
3	USB Type A port	7	RJ-45 console port
4	USB Type A port	8	Ethernet management port

PoE and PoE+ Ports

The ports provide PoE+ support for devices compliant with IEEE 802.3af, IEEE 802.3at, and ePoE and also provide Cisco prestandard PoE support for Cisco IP Phones and Cisco Aironet Access Points.

The maximum switch power output is either 740 W or 370 W, depending on the switch model. Intelligent power management allows flexible power allocation across all ports.

For switches with a 740 W power budget, you can budget the PoE and PoE+:

- 15.4 W of PoE output on 48 ports
- 30 W of PoE+ on 24 ports

For switches with a 370 W power budget, you can budget the PoE and PoE+:

- 15.4 W of PoE output on 24 ports
- 7.7 W of PoE output on 48 ports
- 30 W of PoE+ on 12 ports
- Total power budget can be allocated among the ports

On a per-port basis, you control whether or not a port automatically provides power when an IP phone or an access point is connected.

The PoE ports use RJ-45 connectors with Ethernet pinouts. The maximum cable length is 328 feet (100 meters). The 10BASE-T, 100BASE-TX, 1000BASE-T traffic requires Category 5, Category 5e, or Category 6 unshielded twisted pair (UTP) cable. The 10BASE-T traffic can use Category 3 or Category 4 UTP cable.

Cisco intelligent power management capabilities include enhanced power negotiation, power reservation, and per-port power policing. For information about configuring and monitoring PoE ports, see the switch software configuration guide on Cisco.com.



Note

The output of the PoE circuit has been evaluated as a Limited Power Source (LPS) per IEC 60950-1.

10/100/1000 Ports

The 10/100/1000 ports use RJ-45 connectors with Ethernet pinouts. The maximum cable length is 328 feet (100 meters). The 100BASE-TX traffic requires Category 5, Category 5e, or Category 6 unshielded twisted pair (UTP) cable. The 10BASE-T traffic can use Category 3 or Category 4 UTP cable.

Related Topics

[10/100/1000 Port Connections, on page 63](#)

Management Ports

The management ports connect the switch to a PC running Microsoft Windows or to a terminal server.

- Ethernet management port.
- RJ-45 console port (EIA/TIA-232).
- USB mini-Type B console port (5-pin connector).

The 10/100 Ethernet management port connection uses a standard RJ-45 crossover or straight-through cable. The RJ-45 console port connection uses the supplied RJ-45-to-DB-9 female cable. The USB console port connection uses a USB Type A to 5-pin mini-Type B cable. The USB console interface speeds are the same as the RJ-45 console interface speeds.

If you use the USB mini-Type B console port, the Cisco Windows USB device driver must be installed on any PC connected to the console port (for operation with Microsoft Windows). Mac OS X or Linux do not require special drivers.

The 4-pin mini-Type B connector resembles the 5-pin mini-Type B connectors. They are not compatible. Use only the 5-pin mini-Type B.

This illustration shows a 5-pin mini-Type B USB port.

Figure 3: USB Mini-Type B Port

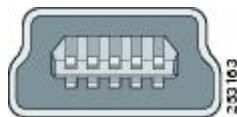

With the Cisco Windows USB device driver, you can connect and disconnect the USB cable from the console port without affecting Windows HyperTerminal operations.

The console output always goes to both the RJ-45 and the USB console connectors, but the console input is active on only one of the console connectors at any one time. The USB console takes precedence over the RJ-45 console. When a cable is connected into the USB console port, the RJ-45 console port becomes inactive. Conversely, when the USB cable is disconnected from the USB console port, the RJ-45 port becomes active.

You can use the command-line interface (CLI) to configure an inactivity timeout which reactivates the RJ-45 console if the USB console has been activated and no input activity has occurred on the USB console for a specified time.

After the USB console deactivates due to inactivity, you cannot use the CLI to reactivate it. Disconnect and reconnect the USB cable to reactivate the USB console. For information on using the CLI to configure the USB console interface, see the software guide.

USB Type A Port

The USB Type A port provides access to external USB flash devices (also known as thumb drives or USB keys).

The port supports Cisco USB flash drives with capacities from 128 MB to 8 GB (USB devices with port densities of 128 MB, 256 MB, 1 GB, 4 GB, and 8 GB are supported). When combined with stacking, you can upgrade other switches in the stack from an USB key inserted in any switch within the stack. Cisco IOS software provides standard file system access to the flash device: read, write, erase, and copy, as well as the ability to format the flash device with a FAT file system.

SFP and SFP+ Module Slots

The switch has either two or four 1-Gigabit SFP or two 10-Gigabit SFP+ module slots. The slots marked *SFP+* support both SFP and SFP+ modules. The *SFP* slots support only the SFP modules.

For Cisco SFP and SFP+ modules documentation, including compatibility matrixes, refer to this URL: http://www.cisco.com/en/US/products/hw/modules/ps5455/products_device_support_tables_list.html

LEDs

You can use the switch LEDs to monitor switch activity and its performance.

This figure shows the switch LEDs and the Mode button that you use to select a port mode.

Figure 4: Switch LEDs and Mode Button for the Catalyst 2960-X Switch

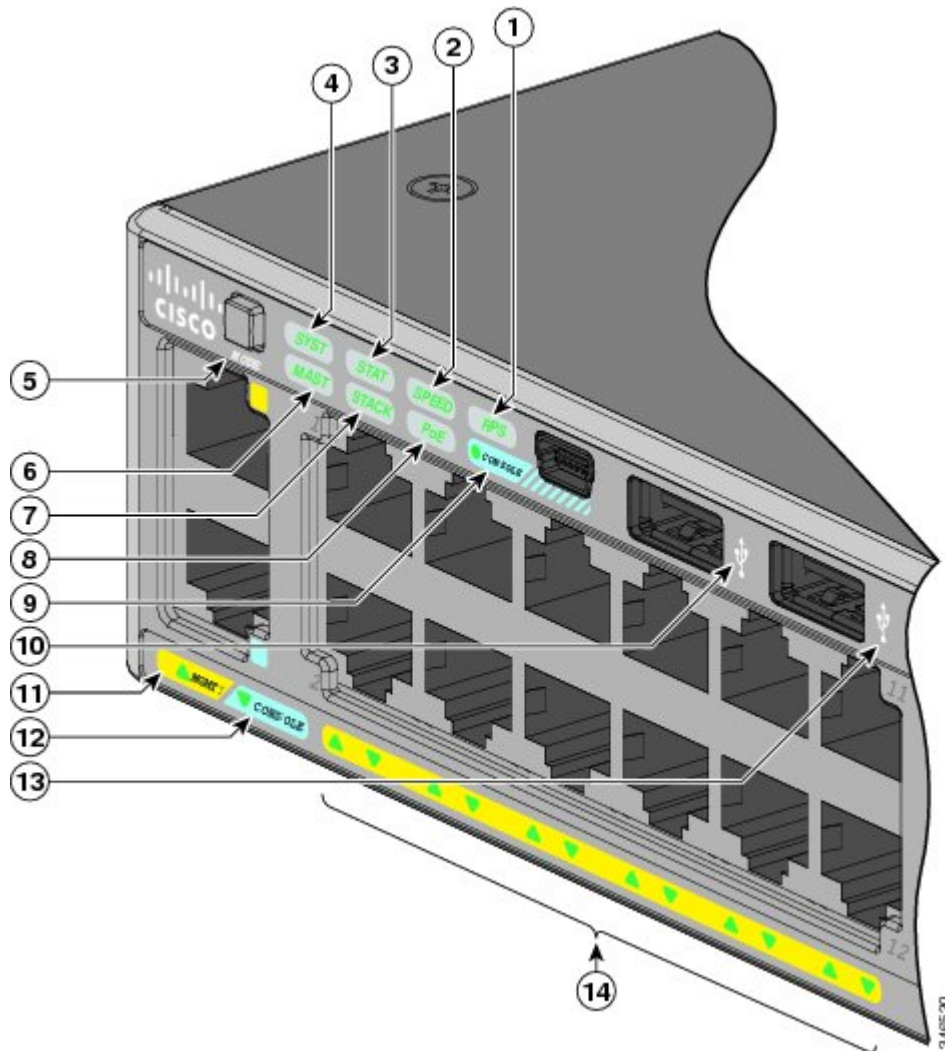

1	RPS LED ⁴	8	PoE LED ⁵
2	SPEED LED	9	USB mini-Type B console port LED
3	STAT LED	10	USB Type A port
4	SYS LED	11	MGMT LED
5	Mode button	12	CONSOLE LED
6	Master LED ⁶	13	USB Type A port
7	STACK LED	14	Port LEDs

- 4 RPS = redundant power system—only on switch models that support RPS.
- 5 Only on switch models that support PoE.
- 6 Only on switch models that support stacking.

This figure shows the switch LEDs and the Mode button that you use to select a port mode.

Figure 5: Switch LEDs and Mode Button for the Catalyst 2960-XR Switch

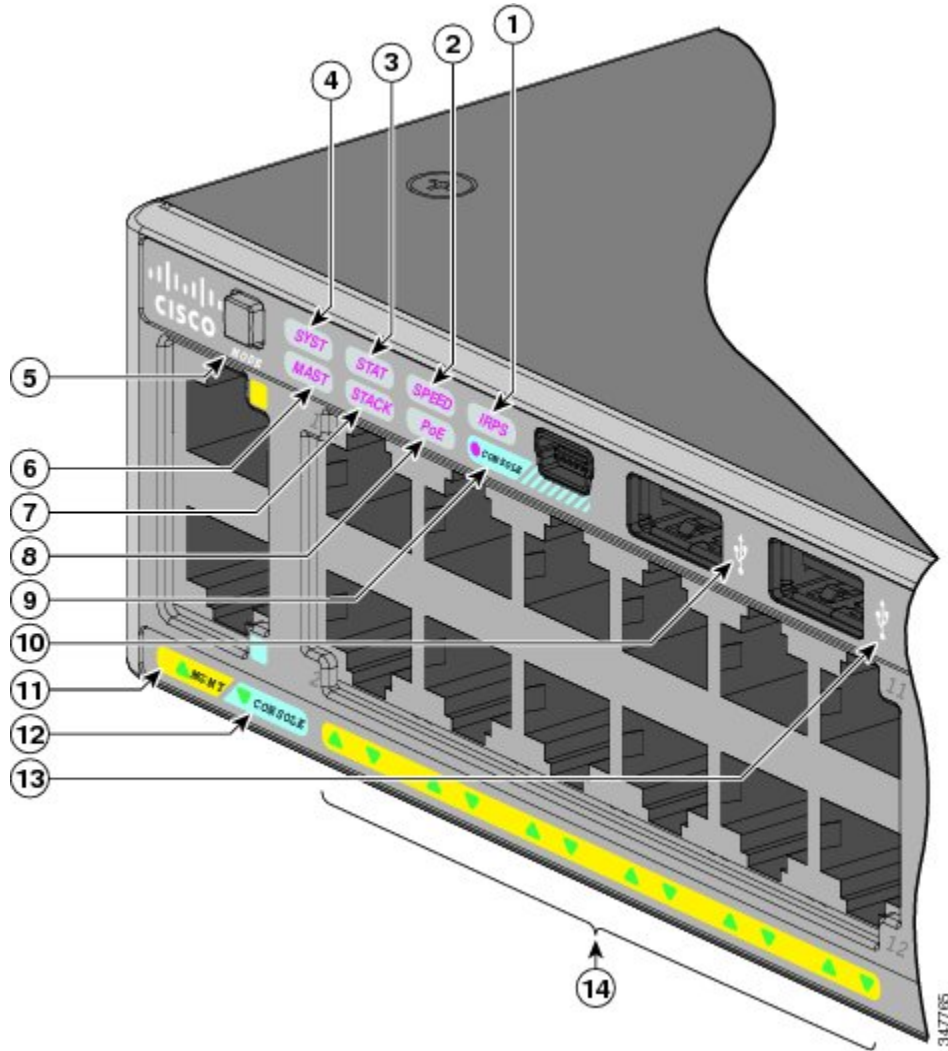

1	IRPS LED	8	PoE LED ²
2	SPEED LED	9	USB mini-Type B console port LED
3	STAT LED	10	USB Type A port
4	SYS LED	11	MGMT LED

5	Mode button	12	CONSOLE LED
6	Master LED ⁸	13	USB Type A port
7	STACK LED	14	Port LEDs

⁷ Only on switch models that support PoE.

⁸ Only on switch models that support stacking.

System LED

Table 3: System LED

Color	System Status
Off	System is not powered on.
Green	System is operating normally.
Blinking green	POST in progress.
Amber	System is receiving power but is not functioning properly.
Blinking amber	System is sleep mode.

RPS LED

The RPS LED is only available on switch models that have an RPS port . This is available only on the Catalyst 2960-X switches.



Note

RPS is not supported on the Catalyst 2960-X 24PSQ-L switches.

Table 4: RPS LED

Color	RPS Status
Off	RPS is off or not properly connected.
Green	RPS is connected and can provide back-up power.
Blinking green	RPS is connected but is unavailable. It is providing power to another device (redundancy has been allocated to the other device).
Amber	The RPS is in standby mode or in a fault condition. See the RPS documentation.

Color	RPS Status
Blinking amber	The power supply in a switch has failed, and the RPS is providing power to the switch (redundancy has been allocated to this device).

IRPS LED

The IRPS LED is only available on Catalyst 2960-XR switches.

Table 5: IRPS LED

Color	RPS Status
Off	Second power supply is not present.
Green	Both power supplies are present and operating.
Amber	The second power supply is present, but the input is not connected.
Blinking amber	The second power supply is present, but the signal is faulty.

Master LED

This table describes the master LEDs.

Table 6: Master LED

Port Mode	Description
Off	Switch is not the stack master.
Green	Switch is the stack master or a standalone switch.
Amber	An error occurred when the stack was electing the stack master switch, or another type of stack error occurred.

Port LEDs and Modes

The port and module slots each has a port LED. As a group or individually, the LEDs show information about the switch and about the ports.

Table 7: Port Mode LEDs

Mode LED	Port Mode	Description
STAT	Port status	The port status. This is the default mode.
SPEED	Port speed	The port operating speed: 10, 100, 1000 Mb/s, or 10 Gb/s.
STACK	Stack member status Stack port status	The stack member status. The stack port status.
PoE	PoE port power	The PoE status.

To select or change a mode, press the Mode button until the desired mode is highlighted. When you change port modes, the meanings of the port LED colors also change.

Table 8: Meanings of LED Colors in Different Modes

Port Mode	Port LED Color	Meaning
PoE	Off	PoE is off. If the powered device is receiving power from an AC power source, the port LED is off even if the powered device is connected to the switch port.
	Green	PoE is on. The port LED is green only when the switch port is providing power.
	Alternating green and amber	PoE is denied because providing power to the powered device will exceed the switch power capacity.
	Blinking amber	PoE is off due to a fault. Noncompliant cabling or powered devices can cause a PoE port fault. Use only standard-compliant cabling to connect Cisco prestandard IP Phones and wireless access points or IEEE 802.3af-compliant devices. You must remove any cable or device that causes a PoE fault.
	Amber	PoE for the port is disabled. (PoE is enabled by default.)

Port Mode	Port LED Color	Meaning
STAT (port status)	Off	No link or port was administratively shut down.
	Green	Link present.
	Blinking green	Activity. Interface is sending or receiving data.
	Alternating green-amber	Link fault. Error frames can affect connectivity, and errors such as excessive collisions, cyclic redundancy check (CRC) errors, and alignment and jabber errors are monitored for a link-fault indication.
	Amber	Port is blocked by Spanning Tree Protocol (STP) and is not forwarding data. After a port is reconfigured, the port LED can remain amber for up to 30 seconds as STP searches the switch for possible loops.
	Blinking amber	Port is blocked by STP and is sending and receiving packets.
SPEED	10/100/1000 ports	
	Off	Port is operating at 10 Mb/s.
	Green	Port is operating at 100 Mb/s.
	Blinking green	Port is operating at 1000 Mb/s.
	SFP module ports	
	Off	Port is operating at 10 Mb/s.
	Green	Port is operating at 100 Mb/s.
	Blinking green	Port is operating at 1000 Mb/s.
	SFP+ module ports (Applies to the Catalyst 2960X-48FPD-L, 2960X-48LPD-L, 2960X-24PD-L, 2960X-48TD-L, and the 2960X-24TD-L switches.) SFP+ module ports (Applies to the Catalyst 2960XR-48FPD-I, 2960XR-48LPD-I, 2960XR-24PD-I, 2960XR-48TD-I, and the 2960XR-24TD-I switches.)	
	Off	Port is not operating.
	Blinking green	Port is operating at 10 Gb/s.
	Green	Port is operating at 1 Gb/s.

Port Mode	Port LED Color	Meaning
STACK (stack member)	Off	No stack member has that member number.
	Blinking green	Stack member number.
	Green	Member numbers of other stack member switches.

If your switches are stacked and you press the Mode button on any switch, all the switches display the same selected mode. For example, if you press the Mode button on the stack master to display SPEED, all the other stack members display SPEED.

Even if PoE mode is not selected, this LED still shows PoE problems if they are detected.

STACK LED

The STACK LED shows the sequence of member switches in a stack. Up to eight switches can be members of a stack. The first eight port LEDs show the switch member number. For example, if you press the Mode button and select Stack, the port LED 1 blinks green. The LEDs for port 2 and 3 are solid green, as these represent the member numbers of other stack members. The other port LEDs are off because there are no more members in the stack.

This figure shows the LEDs on the first switch, which is stack member number 1.

Figure 6: STACK LED

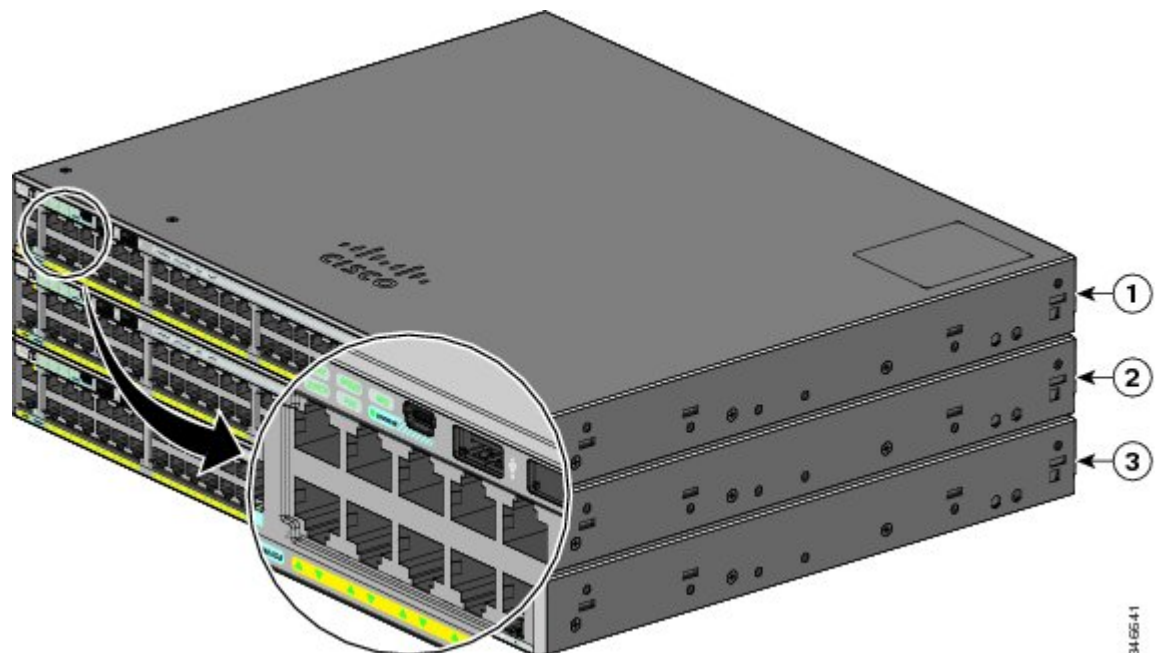

1	Stack member 1	3	Stack member 3
2	Stack member 2		

When you select the STACK LED, the respective STACK LEDs are green when the stack ports (on the switch rear panel) are up, and the respective Stack LEDs are amber when the ports are down. SFP+ module port LEDs 1 and 2 on the switch show the status for stack ports 1 and 2, respectively.

If the port LEDs are green on all the switches in the stack, the stack is operating at full bandwidth. If any port LED is not green, the stack is not operating at full bandwidth.

Console LEDs

The console LEDs show which console port is in use. If you connect a cable to a console port, the switch automatically uses that port for console communication. If you connect two console cables, the USB console port has priority.

Table 9: RJ-45 and USB Console LEDs

LED	Color	Description
RJ-45 console port	Green	RJ-45 console port is active. When this LED is on, the USB console port LED is off.
	Off	The port is not active, and the USB console port is active.
USB console port	Green	USB console port is active. When this LED is on, the RJ-45 console port LED is off.
	Off	The port is not active, and the RJ-45 console port is active.

Ethernet Management Port LED

Table 10: Ethernet Management Port LED

Color	Description
Green	Active link to PC.
Off	Inactive link.
Amber	POST failure.

Rear Panel

The rear panel of the Catalyst 2960-X switches have a FlexStack-Plus module slot, a fan exhaust, an RPS connector, and an AC power connector.

**Note**

The FlexStack-Plus module slot is not available on the Catalyst 2960X-48TS-LL and 2960X-24TS-LL switches. The FlexStack module slot, fan exhaust, and the RPS connector are not available on the Catalyst 2960-X 24PSQ-L switch.

Figure 7: Catalyst 2960-X Switch Rear Panel

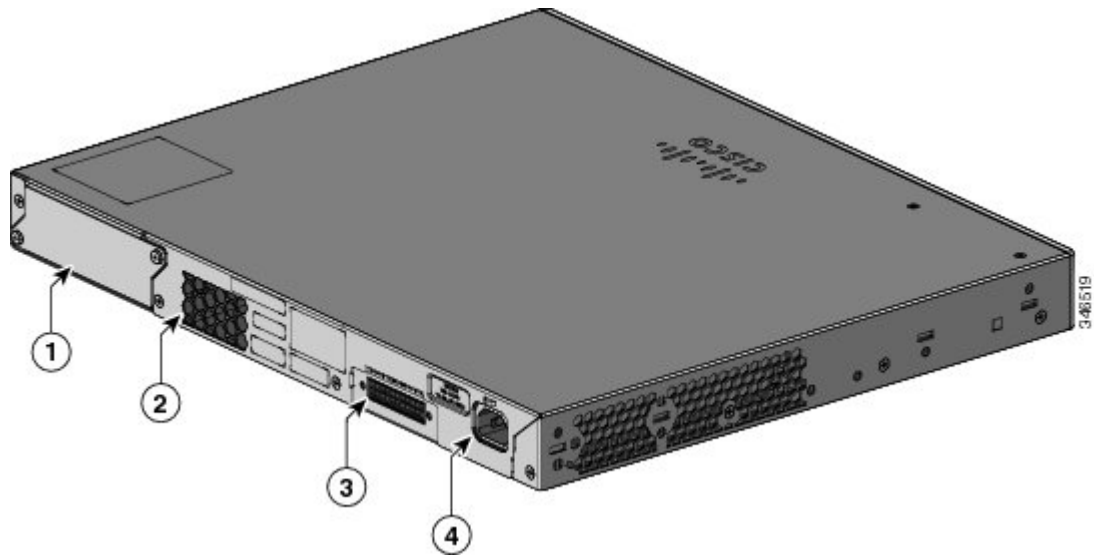

1	FlexStack-Plus module slot and cover	3	RPS Connector
2	Fan Exhaust	4	AC power connector

The rear panel of the Catalyst 2960-XR switches have a FlexStack-Plus module slot and power supply module slots.

Figure 8: Catalyst 2960-XR Switch Rear Panel

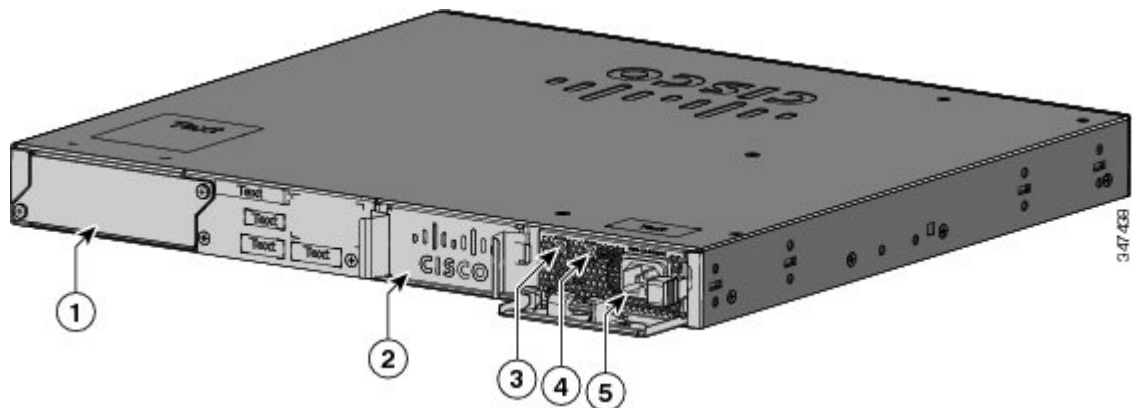

1	FlexStack-Plus module slot and cover	4	PS OK LED
2	Power supply slot (with blank module)	5	AC power connector on the power supply module
3	AC OK LED		

FlexStack-Plus Ports and LEDs

The stacking-capable switch models support stacking with the optional stack kit. It has the FlexStack-Plus module (hot-swappable) that inserts in the slot located in the switch rear panel, and a 0.5-meter FlexStack cable to connect the FlexStack-Plus module ports.

Figure 9: FlexStack-Plus Module

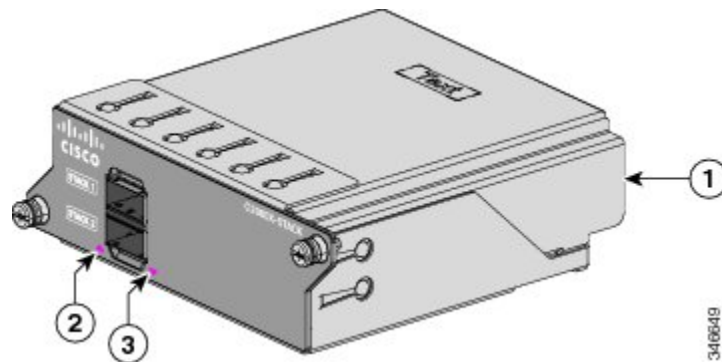

1	FlexStack-Plus module	3	LED for Stack port 2
2	LED for Stack port 1		

This table lists the FlexStack-Plus module LED colors and their meanings.

Table 11: FlexStack-Plus Module LEDs

Color	Description
Green	Port is active, cable is attached.
Off	The port is not active, no cable is attached.

Table 12: Stack Configurations

Switch	Number of Switches in the Stack	Bandwidth
Stack with Catalyst 2960-X stack-capable switches	8	80 G

Switch	Number of Switches in the Stack	Bandwidth
Stack with Catalyst 2960-XR stack-capable switches	8	80 G
Mixed stack with Catalyst 2960-S and Catalyst 2960-X stack-capable switches	4	40 G

RPS Connector

The Cisco RPS 2300 (model PWR-RPS2300) supports the Catalyst 2960-X switch.



Note

RPS is not supported on the Catalyst 2960-X 24PSQ-L switches.



Warning

Attach only the following Cisco RPS model to the RPS receptacle: RPS2300. Statement 370

Connect the switch and the redundant power system to different AC power sources.

Use this cable for the RPS: CAB-RPS2300-E.

Cisco RPS 2300

The Cisco RPS 2300 is a redundant power system that can support six external network devices and provide power to one or two failed devices at a time. It senses when the internal power supply of a connected device fails and provides power to the failed device, preventing loss of network traffic. For more information, see the *Cisco Redundant Power System 2300 Hardware Installation Guide* on Cisco.com at this URL: http://www.cisco.com/en/US/products/ps7148/prod_installation_guides_list.html

The Cisco RPS 2300 has two output levels: -52 V and 12 V with a total maximum output power of 2300 W. All supported and connected switches can simultaneously communicate with the RPS 2300. You can configure these RPS 2300 features through the switch software:

- Enable RPS active or standby mode for each connected switch
- Configure switch priority for RPS support
- List the connected switches and the power-supply module sizes
- Obtain reports when a switch is powered by the RPS
- Obtain status reports for the RPS power-supply module
- Read and monitor backup, failure, and exception history

AC Power Connector



Note This applies to the Catalyst 2960-X switches.

The switch is powered through the internal power supply. The internal power supply is an autoranging unit that supports input voltages between 100 and 240 VAC. Use the supplied AC power cord to plug it into an AC power outlet.

Power Supply Modules (Applies to the Catalyst 2960-XR Switches)

The switch operates with either one or two active power supply modules. You can use two AC modules, or one module and a blank cover.



Note The Catalyst 2960XR-48FPD-I and 2960XR-48FPS-I only support the PWR-C2-1025WAC power supply. You cannot use the PWR-C2-250WAC and PWR-C2-640WAC power supplies in these switches.

Table 13: Power Supply Model Numbers and Description

Part Number	Description
PWR-C2-250WAC=	250-W AC power supply module.
PWR-C2-640WAC=	640-W AC power supply module.
PWR-C2-1025WAC=	1025-W AC power supply module.

The 250-W and 640-W AC power supply modules are autoranging units that support input voltages between 100 and 240 VAC. The 1025-W power supply module is an autoranging unit that supports input voltages between 115 and 240 VAC. All power supply modules have internal fans. All switches ship with a blank cover in the second power supply slot.

Table 14: Available PoE with Different Combinations of Power Supplies

Primary Power Supply	Secondary Power Supply	Available Power for PoE+	Switch Power Redundancy	Available PoE Power when One PS Fails
PWR-C2-250WAC=	—	0	No	—
PWR-C2-250WAC=	PWR-C2-250WAC=	0	Yes	—
PWR-C2-640WAC=	—	370 W	No	—
PWR-C2-640WAC=	PWR-C2-640WAC=	370 W	Yes	370 W

Primary Power Supply	Secondary Power Supply	Available Power for PoE+	Switch Power Redundancy	Available PoE Power when One PS Fails
PWR-C2-1025WAC=	—	740 W	No	—
PWR-C2-1025WAC=	PWR-C2-1025WAC=	740 W	Yes	740 W

Management Options

- Cisco Network Assistant

Cisco Network Assistant is a PC-based network management GUI application for LANs of small and medium-sized businesses. You can use the GUI to configure and manage switch clusters or standalone switches. Cisco Network Assistant is available at no cost and can be downloaded from this URL: <http://www.cisco.com/en/US/products/ps5931/index.html>

For information on starting the Network Assistant application, see the *Getting Started with Cisco Network Assistant* guide on Cisco.com.

- Device Manager

You can use Device Manager in the switch memory to manage individual and standalone switches. This web interface provides configuration and monitoring from anywhere in your network. For information, see the switch getting started guide and the Device Manager online help.

- Cisco IOS CLI

You can configure and monitor the switch and switch cluster members from the CLI. Access the CLI by connecting your management station to the switch console port or by using Telnet from a remote management station. See the switch command reference on Cisco.com for information.

- Cisco Prime Infrastructure

Cisco Prime Infrastructure combines the wireless functionality of Cisco Prime Network Control System (NCS) and the wired functionality of Cisco Prime LAN Management Solution (LMS), with application performance monitoring and troubleshooting capabilities of Cisco Prime Assurance Manager. For more information, see the Cisco Prime Infrastructure documentation on Cisco.com.

- Catalyst Smart Operations

The Smart Install feature provides a single point of management (director) in a network. You can use it to provide a zero touch image and configuration upgrade of newly deployed switches and image and configuration downloads for any client switches. For information, see the *Cisco Smart Install Configuration Guide* on Cisco.com.

Auto Smartports macros dynamically configure ports based on the device type detected on the port. When the switch detects a new device, it applies the appropriate Auto Smartports macro on the port. For information about configuring Auto Smartports, see the switch software configuration guide on Cisco.com.

Network Configurations

See the switch software configuration guide on [Cisco.com](https://www.cisco.com) for network configuration concepts and examples of using the switch to create dedicated network segments and interconnecting the segments through Fast Ethernet and Gigabit Ethernet connections.



Switch Installation

For initial switch setup, assigning the switch IP address, and powering on information, see the switch getting started guide on Cisco.com.

This chapter contains these topics:

- [Safety Warnings, page 23](#)
- [Box Contents, page 26](#)
- [Tools and Equipment, page 26](#)
- [Installation Guidelines, page 26](#)
- [Verifying Switch Operation, page 27](#)
- [Planning and Installing a Switch Stack \(Optional\), page 28](#)
- [Installing the Switch, page 33](#)
- [Connecting the FlexStack Cables \(Optional\), page 41](#)
- [Installing the Power Cord Retainer \(Optional\), page 43](#)
- [Installing SFP and SFP+ Modules, page 45](#)
- [Connecting to SFP and SFP+ Modules, page 47](#)
- [10/100/1000 PoE+ Port Connections, page 50](#)
- [10/100/1000 Port Connections, page 51](#)
- [Where to Go Next, page 52](#)

Safety Warnings

This section includes the basic installation caution and warning statements. Read this section before you start the installation procedure. Translations of the warning statements appear in the RCSI guide on Cisco.com.

**Warning**

Before working on equipment that is connected to power lines, remove jewelry (including rings, necklaces, and watches). Metal objects will heat up when connected to power and ground and can cause serious burns or weld the metal object to the terminals. Statement 43

**Warning**

Do not stack the chassis on any other equipment. If the chassis falls, it can cause severe bodily injury and equipment damage. Statement 48

**Warning**

This product must be connected to a power-over-ethernet (PoE) IEEE 802.3af compliant power source or an IEC60950 compliant limited power source. Statement 353

**Warning**

Read the wall-mounting instructions carefully before beginning installation. Failure to use the correct hardware or to follow the correct procedures could result in a hazardous situation to people and damage to the system. Statement 378

**Warning**

If a Cisco external power system is not connected to the switch, install the provided connector cover on the back of the switch. Statement 386

**Warning**

Attach only the following Cisco external power system to the switch: PWR-RPS2300 Statement 387

**Warning**

Do not work on the system or connect or disconnect cables during periods of lightning activity. Statement 1001

**Warning**

Read the installation instructions before connecting the system to the power source. Statement 1004

**Warning**

To prevent bodily injury when mounting or servicing this unit in a rack, you must take special precautions to ensure that the system remains stable. The following guidelines are provided to ensure your safety:

- This unit should be mounted at the bottom of the rack if it is the only unit in the rack.
- When mounting this unit in a partially filled rack, load the rack from the bottom to the top with the heaviest component at the bottom of the rack.
- If the rack is provided with stabilizing devices, install the stabilizers before mounting or servicing the unit in the rack.

Statement 1006

- 
Warning Class 1 laser product. Statement 1008

- 
Warning This unit is intended for installation in restricted access areas. A restricted access area can be accessed only through the use of a special tool, lock and key, or other means of security. Statement 1017

- 
Warning The plug-socket combination must be accessible at all times, because it serves as the main disconnecting device. Statement 1019

- 
Warning This equipment must be grounded. Never defeat the ground conductor or operate the equipment in the absence of a suitably installed ground conductor. Contact the appropriate electrical inspection authority or an electrician if you are uncertain that suitable grounding is available. Statement 1024

- 
Warning This unit might have more than one power supply connection. All connections must be removed to de-energize the unit. Statement 1028

- 
Warning Only trained and qualified personnel should be allowed to install, replace, or service this equipment. Statement 1030

- 
Warning Ultimate disposal of this product should be handled according to all national laws and regulations. Statement 1040

- 
Warning For connections outside the building where the equipment is installed, the following ports must be connected through an approved network termination unit with integral circuit protection: 10/100/1000 Ethernet. Statement 1044

- 
Warning When installing or replacing the unit, the ground connection must always be made first and disconnected last. Statement 1046

- 
Warning To prevent the system from overheating, do not operate it in an area that exceeds the maximum recommended ambient temperature of: <113°F (45°C). Statement 1047

**Warning**

This warning symbol means danger. You are in a situation that could cause bodily injury. Before you work on any equipment, be aware of the hazards involved with electrical circuitry and be familiar with standard practices for preventing accidents. Use the statement number provided at the end of each warning to locate its translation in the translated safety warnings that accompanied this device. Statement 1071

**Warning**

Voltages that present a shock hazard may exist on Power over Ethernet (PoE) circuits if interconnections are made using uninsulated exposed metal contacts, conductors, or terminals. Avoid using such interconnection methods, unless the exposed metal parts are located within a restricted access location and users and service people who are authorized within the restricted access location are made aware of the hazard. A restricted access area can be accessed only through the use of a special tool, lock and key or other means of security. Statement 1072

**Warning**

No user-serviceable parts inside. Do not open. Statement 1073

**Warning**

Installation of the equipment must comply with local and national electrical codes. Statement 1074

**Warning**

To prevent airflow restriction, allow clearance around the ventilation openings to be at least: 3 inches (7.6 cm). Statement 1076

**Warning**

Hot surface. Statement 1079

Applies to the Catalyst 2960X-24PSQ-L switches.

Box Contents

The switch getting started guide describes the box contents. If any item is missing or damaged, contact your Cisco representative or reseller for support.

Tools and Equipment

Obtain these necessary tools and equipment:

- A number-2 Phillips screwdriver to rack-mount the switch.

Installation Guidelines

When determining where to install the switch, verify that these guidelines are met:

- Clearance to the switch front and rear panel meets these conditions:
 - Front-panel LEDs can be easily read.
 - Access to ports is sufficient for unrestricted cabling.
 - AC power cord can reach from the AC power outlet to the connector on the switch rear panel.
 - Access to the rear of the rack is sufficient for connecting FlexStack cables to stacked switches, or connecting the optional Cisco Redundant Power Supply (RPS) 2300.
- Cabling is away from sources of electrical noise, such as radios, power lines, and fluorescent lighting fixtures. Make sure that the cabling is safely away from other devices that might damage the cables.
- For switches with the optional 1025-W power-supply module, first rack-mount the switch before installing the power-supply module.
- Make sure power-supply modules are securely inserted in the chassis before moving the switch.
- When connecting or disconnecting the power cord on a switch that is installed above or below a 1025-W power supply-equipped switch, you might need to remove the module from the switch to access the power cord.
- Airflow around the switch and through the vents is unrestricted.
- For the Catalyst 2960X-24PSQ-L switches: Allow these clearances:
 - Top and bottom: 1.75 in. (44.44 mm)
 - Back of switch: 3 in. (76.19 mm)
- Temperature around the unit does not exceed 113°F (45°C). If the switch is installed in a closed or multirack assembly, the temperature around it might be greater than normal room temperature.
- Humidity around the switch does not exceed 95 percent.
- Altitude at the installation site is not greater than 10,000 feet.
- For 10/100/1000 fixed ports, the cable length from a switch to a connected device cannot exceed 328 feet (100 meters).
- Cooling mechanisms, such as fans and blowers in the switch, can draw dust and other particles causing contaminant buildup inside the chassis, which can result in system malfunction. You must install this equipment in an environment as free from dust and foreign conductive material (such as metal flakes from construction activities) as is possible.

Verifying Switch Operation

Before you install the switch in a rack, on a wall, or on a table or shelf, power on the switch and verify that it passes POST.

To power on the switch, plug one end of the AC power cord into the switch AC power connector, and plug the other end into an AC power outlet.

As the switch powers on, it begins the POST, a series of tests that runs automatically to ensure that the switch functions properly. LEDs can blink during the test. POST lasts approximately 1 minute. When the switch

begins POST, the SYST, RPS, STAT, and SPEED LEDs turn green. The SYST LED blinks green, and the other LEDs remain solid green.

When the switch completes POST successfully, the SYST LED remains green. The RPS LED remains green for some time and then reflects the switch operating status. The other LEDs turn off and then reflect the switch operating status. If a switch fails POST, the SYST LED turns amber.

POST failures are usually fatal. Call Cisco technical support representative if your switch fails POST.

After a successful POST, unplug the power cord from the switch and install the switch in a rack, on a wall, on a table, or on a shelf.

If your configuration has an RPS, connect the switch and the RPS to different AC power sources. See the Cisco RPS documentation for information.

**Note**

When you connect the RPS to the switch, put the RPS in standby mode. Set the RPS to active mode during normal operation.

**Warning**

Attach only the following Cisco external power system to the switch: PWR-RPS2300 Statement 387

Planning and Installing a Switch Stack (Optional)

**Note**

This section applies only to the Catalyst 2960-X and 2960-XR stacking-capable switches.

Stack Guidelines

- Connect only Catalyst 2960-X or 2960-S switches in a mixed switch stack.

**Note**

You can only create mixed stacks with Catalyst 2960-X or 2960-S switches (up to four switches). You cannot create mixed stacks with other switches. Catalyst 2960-XR switches cannot be added to mixed stacks. They can only stack with other Catalyst 2960-XR switches.

- Install the FlexStack-Plus module and the FlexStack cable.

**Note**

The FlexStack-Plus module is hot-swappable and can be inserted while the switch is powered on.

- Order the appropriate cable from your Cisco sales representative. The length of FlexStack cable depends on your configuration. These are the different sizes available:

- CAB-STK-E-0.5M= (0.5-meter cable)
 - CAB-STK-E-1M= (1-meter cable)
 - CAB-STK-E-3M= (3-meter cable)
- Make sure that you have access to the switch rear panel and to the rear of the rack.

Installing the FlexStack-Plus Module

**Note**

The switch should always have a blank module installed when a FlexStack-Plus module is not used.

The Catalyst 2960X-48P-L switch is shown as an example. You can install the module in other switches as shown.

Procedure

- Step 1** Use a number 2 Phillips-head screwdriver to remove the FlexStack-Plus module blank cover on the switch back panel.

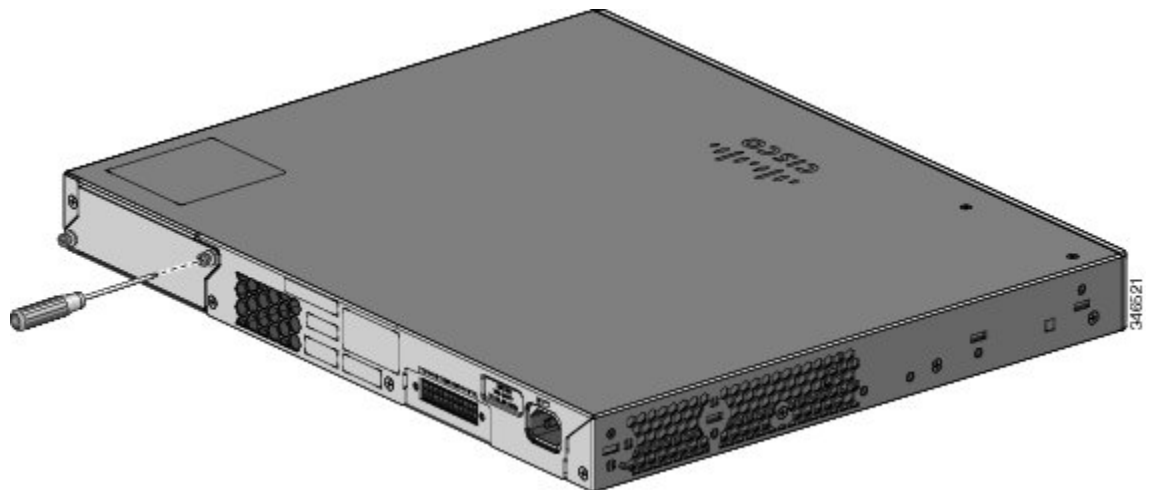

- Step 2** Grasp the FlexStack-Plus module on the sides, and insert it into the module slot. Push the module in completely until you feel it snap into place.

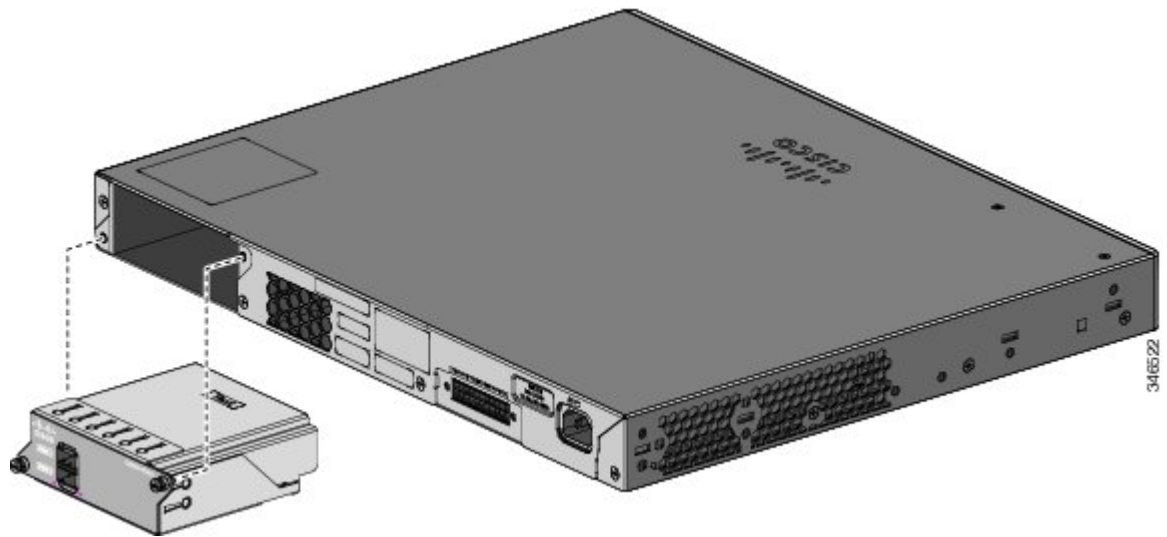

Step 3 Secure the screws on each side of the module.

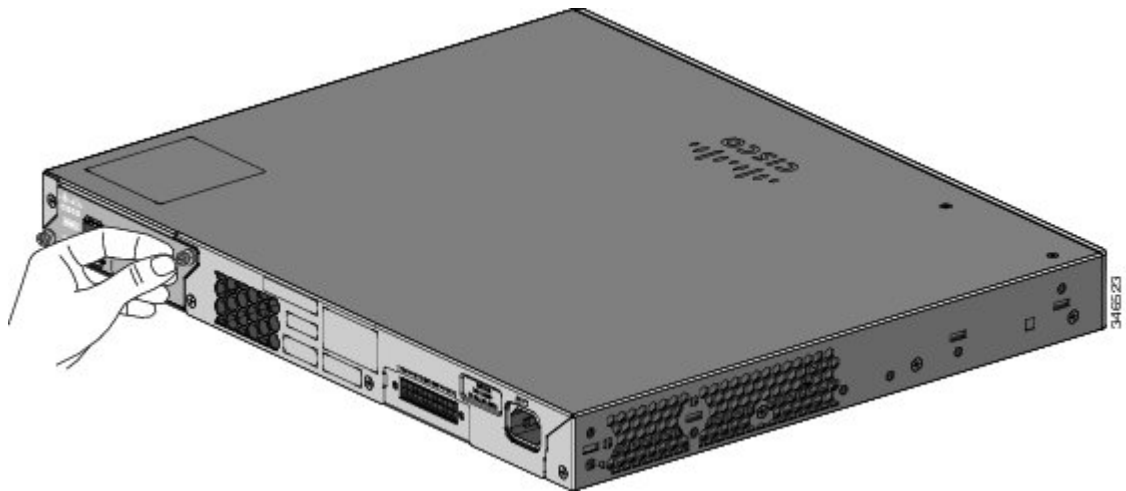

Note Avoid overtightening the screws.

Stack Cabling

These figures show the switches stacked in a vertical rack or on a table. The connections are redundant. A Catalyst 2960-X switch is shown in the examples, the Catalyst 2960-XR switch can be stacked in the same way.

Figure 10: Stacking Switches with the 0.5-meter FlexStack Cable

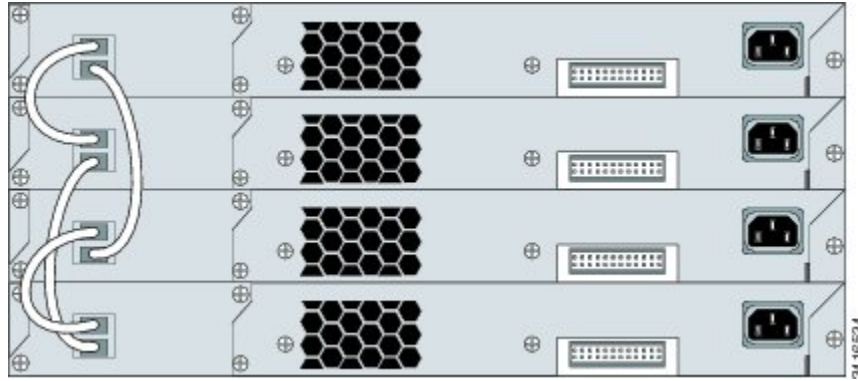
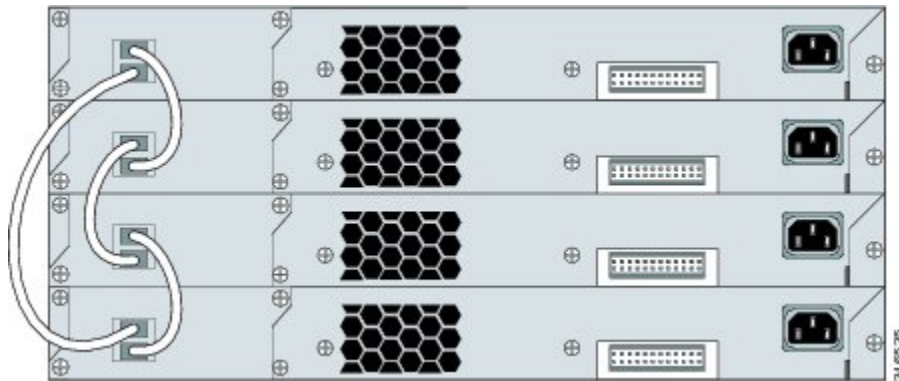

Figure 11: Stacking Switches with 0.5-meter and 3-meter FlexStack Cables



Stack Bandwidth and Partitioning Examples

This figure shows a stack that provides full bandwidth with redundant connections.

Figure 12: Stack with Full Bandwidth Connections

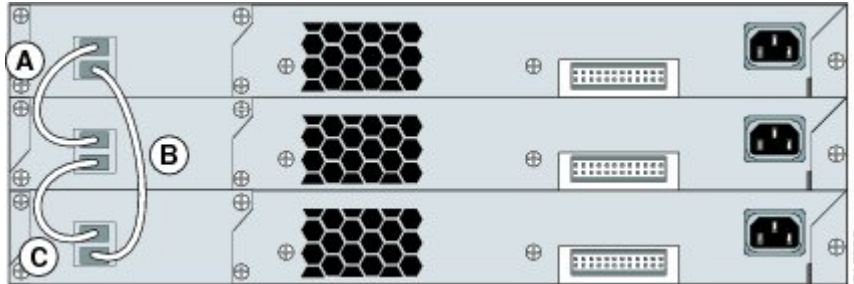

This figure shows a stack with incomplete stack cabling connections. This stack provides only half bandwidth and does not have redundant connections.

Figure 13: Stack with Half Bandwidth Connections

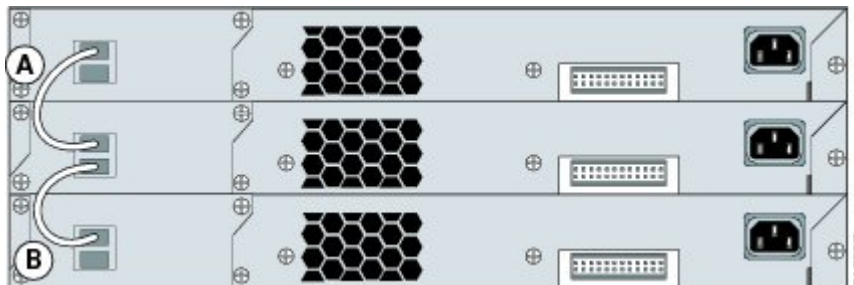

This figure shows a stack with a bad FlexStack cable in link B. This stack provides only half bandwidth and does not have redundant connections.

Figure 14: Stack with a Failover Condition

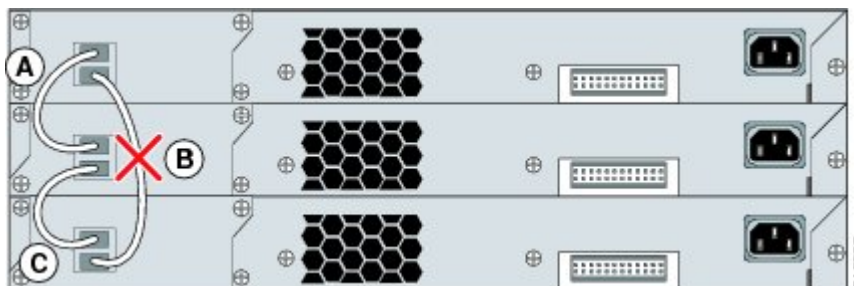

This figure shows a stack with a bad link B. This stack partitions into two stacks, and switch 1 and switch 3 are stack masters.

Figure 15: Partitioned Stack with a Failover Condition

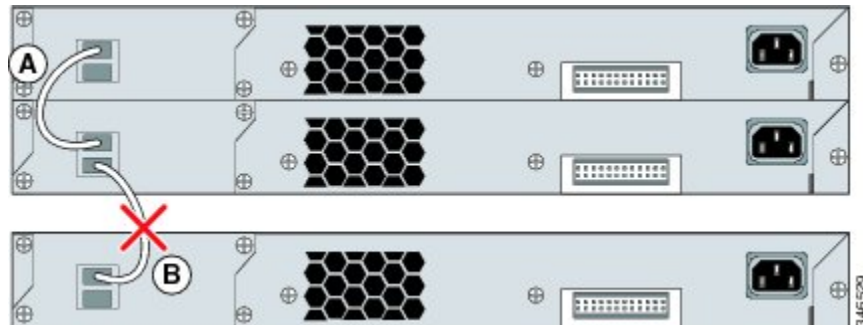

Power-On Sequence for Switch Stacks

Consider these guidelines before you power on the switches in a stack:

- The sequence in which the switches are first powered on might affect the switch that becomes the stack master.
- If you want a particular switch to be the stack master, power on that switch first. This switch becomes the stack master and remains the stack master until a master reelection. After 2 minutes, power on the other stack switches.
- If you have no preference as to which switch becomes the stack master, power on all the switches in the stack within a 1-minute timeframe. These switches participate in the stack master election. Switches powered on after the 1-minute timeframe do not participate in the election.
- Power off a switch before you add it to or remove it from an existing switch stack.

For conditions that can cause a stack master reelection or to manually elect the stack master, see the *Catalyst 2960-X Switch Stacking Configuration Guide* or *Catalyst 2960-XR Switch Stacking Configuration Guide* on Cisco.com.

Installing the Switch

Rack-Mounting

Installation in other than 19-inch racks requires a bracket kit not included with the switch.

**Warning**

To prevent bodily injury when mounting or servicing this unit in a rack, you must take special precautions to ensure that the system remains stable. The following guidelines are provided to ensure your safety:

- This unit should be mounted at the bottom of the rack if it is the only unit in the rack.
- When mounting this unit in a partially filled rack, load the rack from the bottom to the top with the heaviest component at the bottom of the rack.
- If the rack is provided with stabilizing devices, install the stabilizers before mounting or servicing the unit in the rack.

Statement 1006

This figure shows the standard 19-inch brackets and other optional mounting brackets. You can order the optional brackets from your Cisco sales representative.

Figure 16: Rack-Mounting Brackets

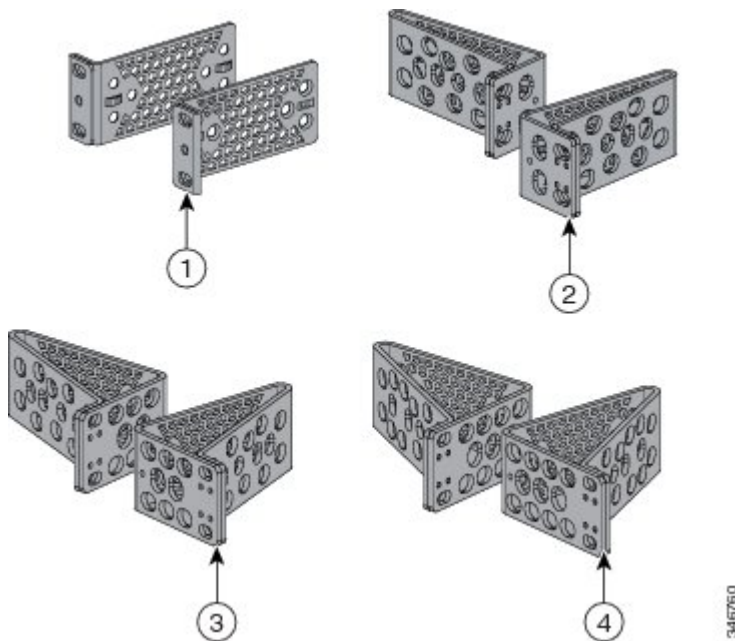

1	19-inch brackets	3	23-inch brackets
2	ETSI brackets	4	24-inch brackets

Attaching the Rack-Mount Brackets for the Catalyst 2960-X Switches

Procedure

Use two Phillips flat-head screws to attach the long side of the bracket to each side of the switch.

Figure 17: Attaching Brackets for 19-inch Racks

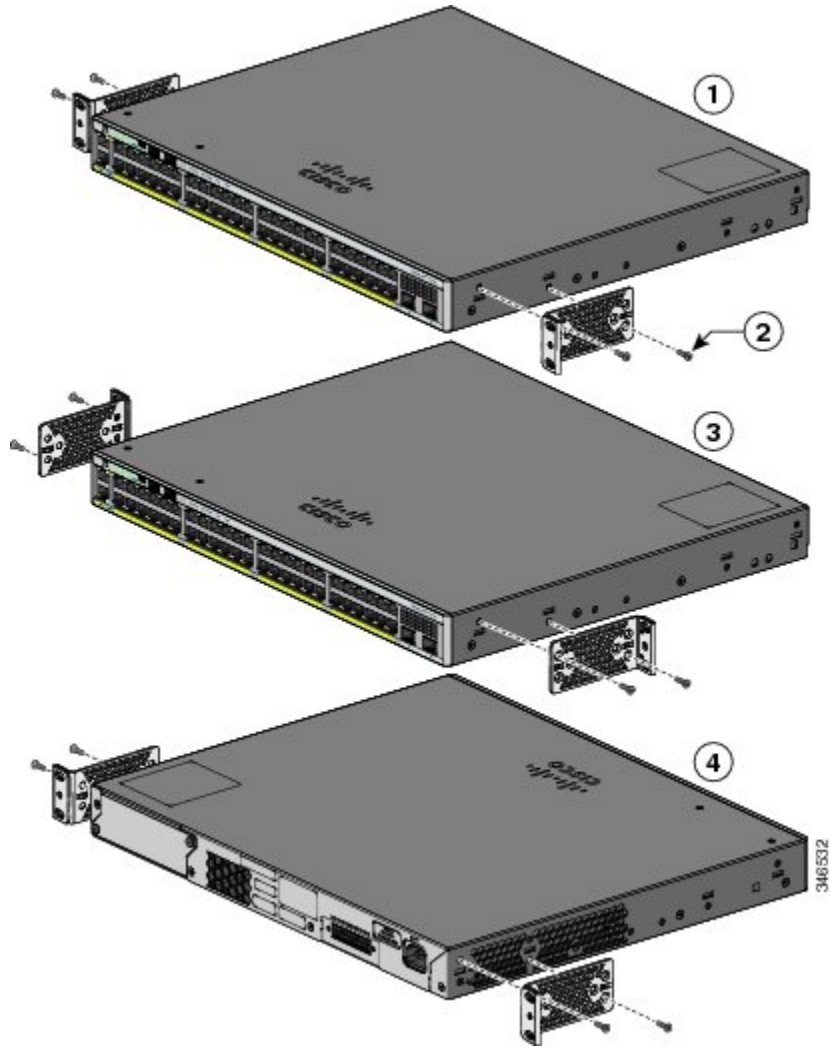

1	Front-mounting position	3	Mid-mounting position
2	Number-8 Phillips flat-head screws (48-2927-01)	4	Rear-mounting position

Attaching the Rack-Mount Brackets for the Catalyst 2960-XR Switches

Procedure

Use four Phillips flat-head screws to attach the long side of the bracket to each side of the switch.

Figure 18: Attaching Brackets for 19-inch Racks

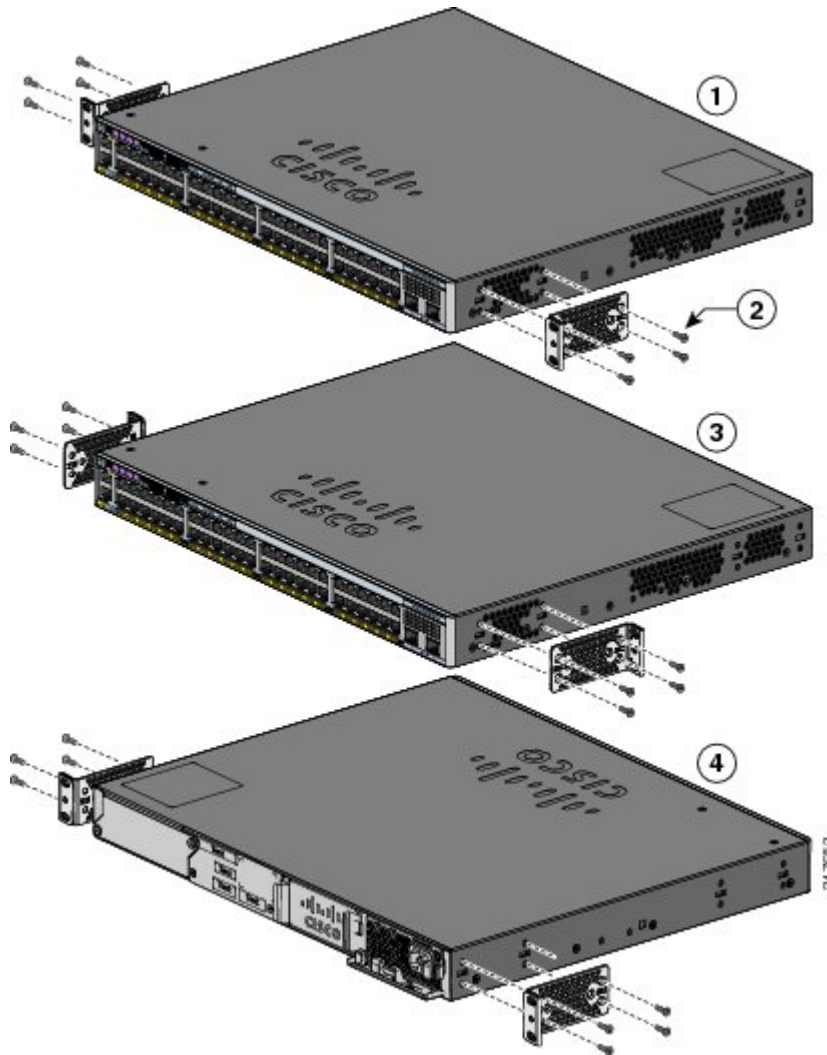

1	Front-mounting position	3	Mid-mounting position
2	Number-8 Phillips flat-head screws (48-2927-01)	4	Rear-mounting position

Mounting in a Rack

Procedure

- Step 1** Use the four supplied Phillips machine screws to attach the brackets to the rack.
- Step 2** Use the black Phillips machine screw to attach the cable guide to the left or right bracket.

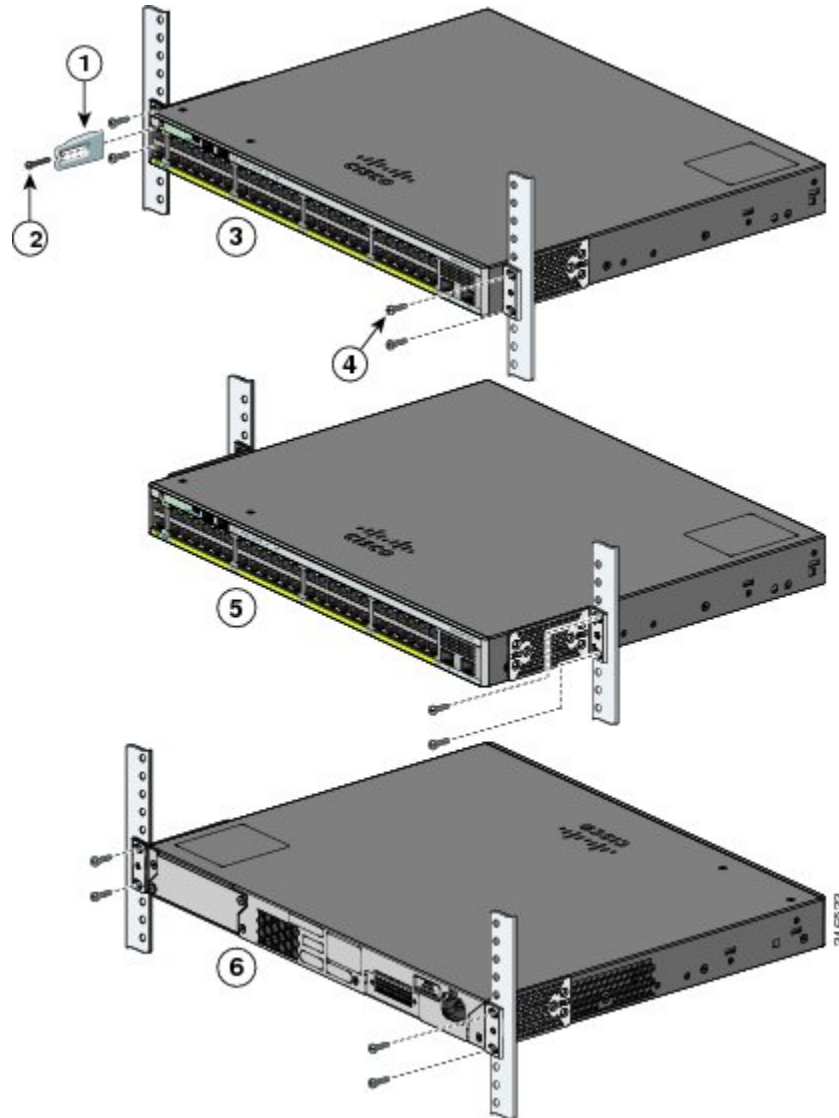

1	Cable guide	4	Number-12 Phillips pan-head screws (48-0523-01) or Number-10 Phillips pan-head screws (48-0627-01)
2	Phillips machine screw, black (48-0654-01)	5	Mid-mounting position

3	Front-mounting position	6	Rear-mounting position
---	-------------------------	---	------------------------

Wall-Mounting



Warning

Read the wall-mounting instructions carefully before beginning installation. Failure to use the correct hardware or to follow the correct procedures could result in a hazardous situation to people and damage to the system. Statement 378

Attaching the Brackets for Wall-Mounting

Procedure

- Step 1** Attach a 19-inch bracket to one side of the switch.
- Step 2** Follow the same steps to attach the second bracket to the opposite side.

Figure 19: Attaching the 19-inch Brackets for Wall-Mounting

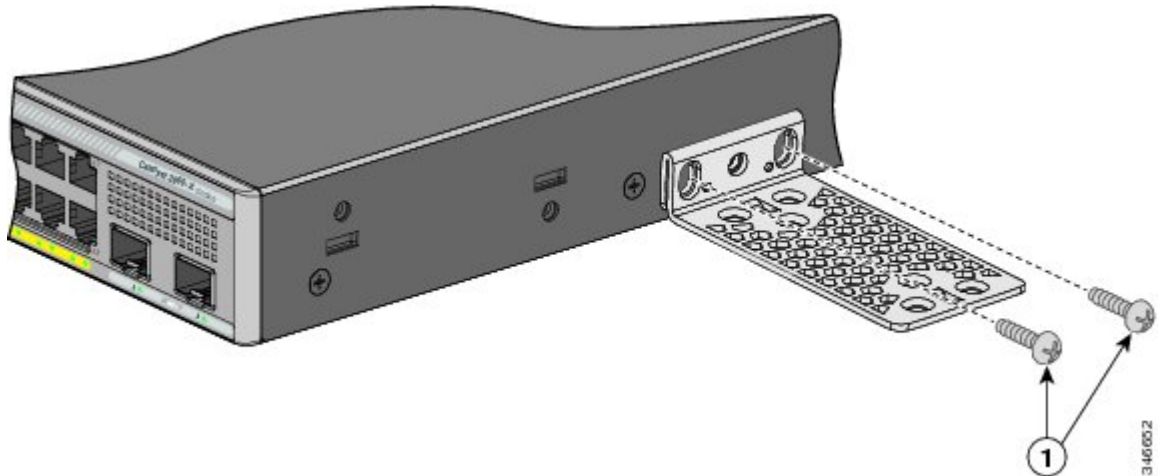

1	Number-8 phillips flat-head screws (48-2927-01)
---	---

Attaching the RPS Connector Cover

This section only applies to the switches that have an RPS port.

Warning

If an RPS is not connected to the switch, install an RPS connector cover on the back of the switch. Statement 265

Before You Begin



Note

The Catalyst 2960X-24PSQ-L switches do not have an RPS connector and a cover is not needed.

Procedure

If you are not using an RPS with your switch, use the two Phillips pan-head screws to attach the RPS connector cover to the back of the switch.

Figure 20: Attaching the RPS Connector Cover

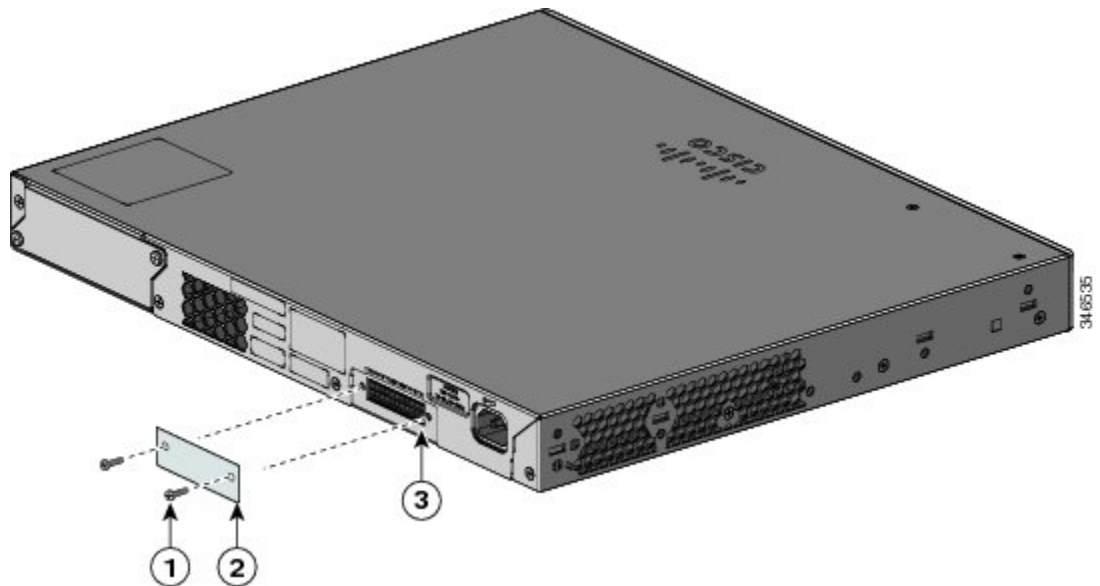

1	Phillips pan-head screws (48-0482-01)	3	RPS connector
2	RPS connector cover		

Mounting on a Wall

For the best support of the switch and cables, make sure that the switch is attached securely to wall studs or to a firmly attached plywood-mounting backboard. Mount the switch with the front panel facing down.



Warning

Read the wall-mounting instructions carefully before beginning installation. Failure to use the correct hardware or to follow the correct procedures could result in a hazardous situation to people and damage to the system. Statement 378



Caution

Following safety regulations, wall-mount the switch with its front panel facing down.

Figure 21: Mounting on a Wall

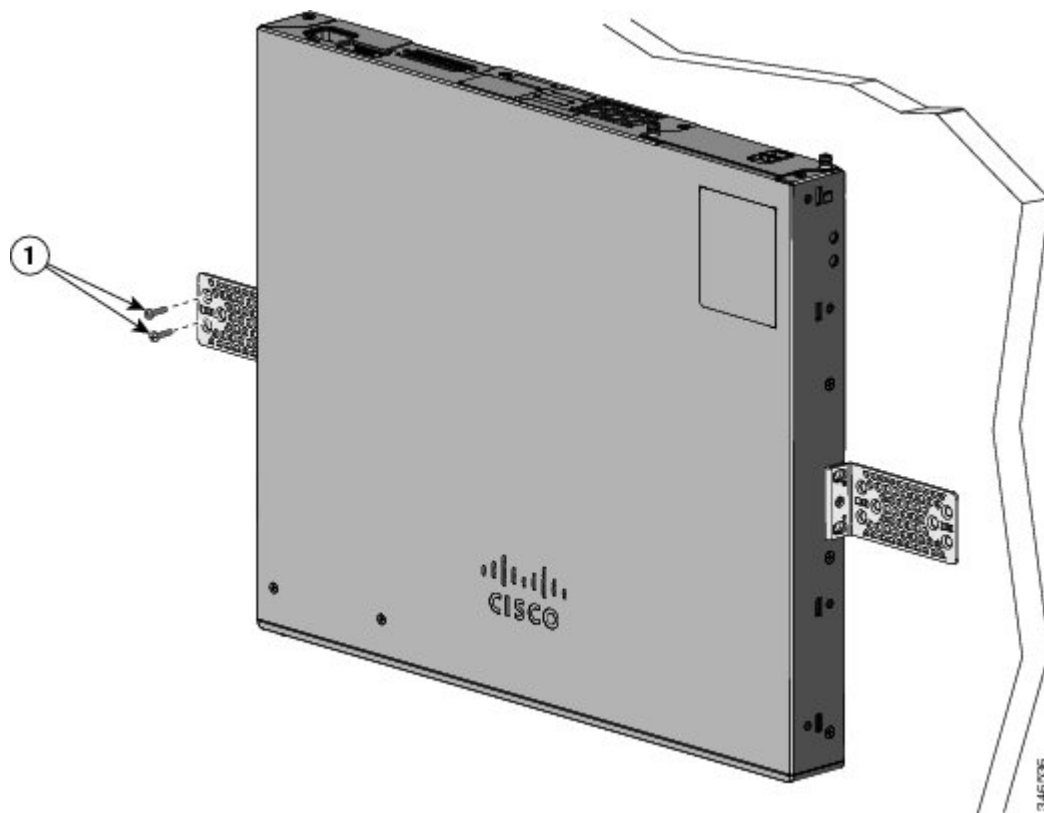

1	User-supplied screws (for example, you can use # 6 wood screws with a washer head 1-inch long).
---	---

When you complete the switch installation, see [After Switch Installation](#), on page 41 for information on switch configuration.

Installing the Switch on a Table or Shelf

Procedure

- Step 1** To install the switch on a table or shelf, locate the adhesive strip with the rubber feet in the mounting-kit envelope.
- Step 2** Attach the four rubber feet to the four circular etches on the bottom of the chassis.
- Step 3** Place the switch on the table or shelf near an AC power source.
- Step 4** When you complete the switch installation, see [After Switch Installation, on page 41](#) for information on switch configuration.
-

After Switch Installation

- Configure the switch by running Express Setup to enter the initial switch configuration. See the switch getting started guide on Cisco.com.
- Use the CLI setup program to enter the initial switch configuration.
- Connect to the stack ports.
- Install the power cord retainer (optional).
- Connect to the front-panel ports.

Related Topics

- [Connecting the FlexStack Cables \(Optional\), on page 41](#)
- [Installing the Power Cord Retainer \(Optional\), on page 43](#)
- [Installing an SFP or SFP+ Module, on page 46](#)
- [10/100/1000 PoE+ Port Connections, on page 50](#)

Connecting the FlexStack Cables (Optional)

Always use a Cisco-approved FlexStack cable to connect the switches.



Note

This is only supported on the stack-capable switches.



Caution

Use only approved cables, and connect only to other Catalyst 2960-X or 2960-S switches. Equipment might be damaged if connected to other nonapproved Cisco cables or equipment.

Procedure

-
- Step 1** Remove the dust covers from the FlexStack cables, and store them for future use.
- Step 2** Insert one end of the FlexStack cable into the stack port of the first switch. Insert the other end of the cable into the stack port on the other switch. Make sure that you insert the cables in completely until you feel them snap into place.

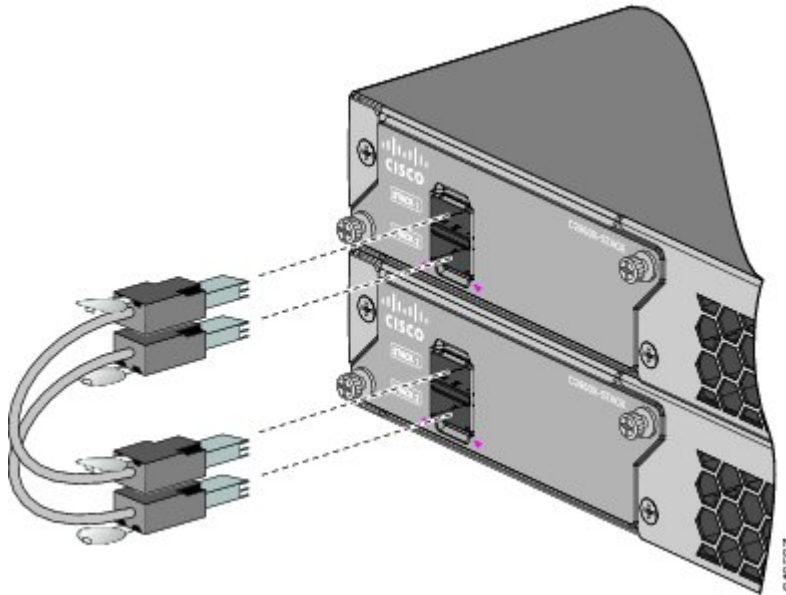

Note When you connect the FlexStack cable to the STACK 1 port, the tab should be above the connector. When you connect the FlexStack cable to the STACK 2 port, the tab should be below the connector.

- Step 3** Replace the dust covers when you remove the FlexStack cables from the connectors.

Caution Removing and installing the FlexStack cable can shorten its useful life. Do not remove and insert the cable more often than is absolutely necessary.

Removing a FlexStack Cable

Procedure

-
- Step 1** To remove a FlexStack cable, grasp the tab on the cable connector and gently pull straight out.
- Step 2** When you remove the FlexStack cables from the connectors, replace the dust covers to protect them from dust.
- Caution** Removing and installing the FlexStack cable can shorten its useful life. Do not remove and insert the cable more often than is absolutely necessary.
-

Installing the Power Cord Retainer (Optional)



Note This section applies only to the Catalyst 2960-X switches.

The power cord retainer is optional (part number [PWR-CLP=]). You can order it when you order your switch, or you can order it later from your Cisco representative.

Procedure

- Step 1** Choose the sleeve size of the power cord retainer based on the thickness of the cord. The smaller sleeve can be snapped off and used for thin cords.
- Step 2** Slide the retainer around the AC power cord, and pass it around the loop on the switch.

Figure 22: Inserting the Retainer Through the Lanced Loop

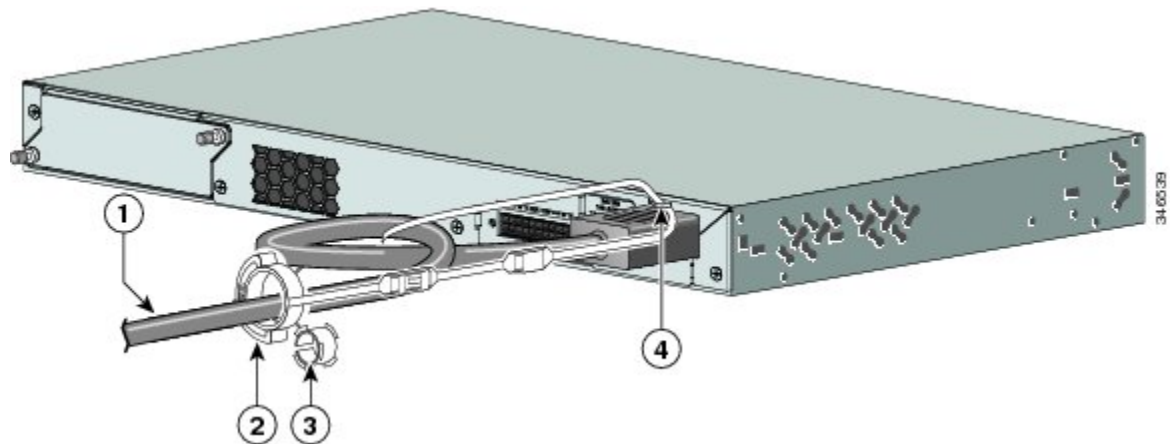

1	AC power cord	3	Sleeve for thinner power cords
2	Power cord retainer	4	Loop

Step 3 Slide the retainer through the first latch.

Figure 23: Sliding the Retainer Through the Latch

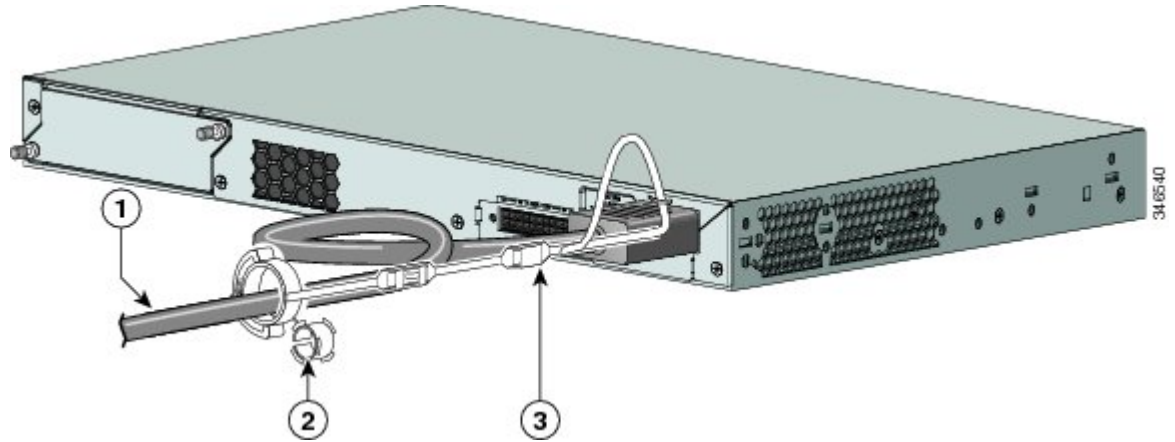

1	AC power cord	3	Latch
2	Smaller sleeve for thin power cords		

Step 4 Slide the retainer through the other latches to lock it.

Figure 24: Locking the Retainer

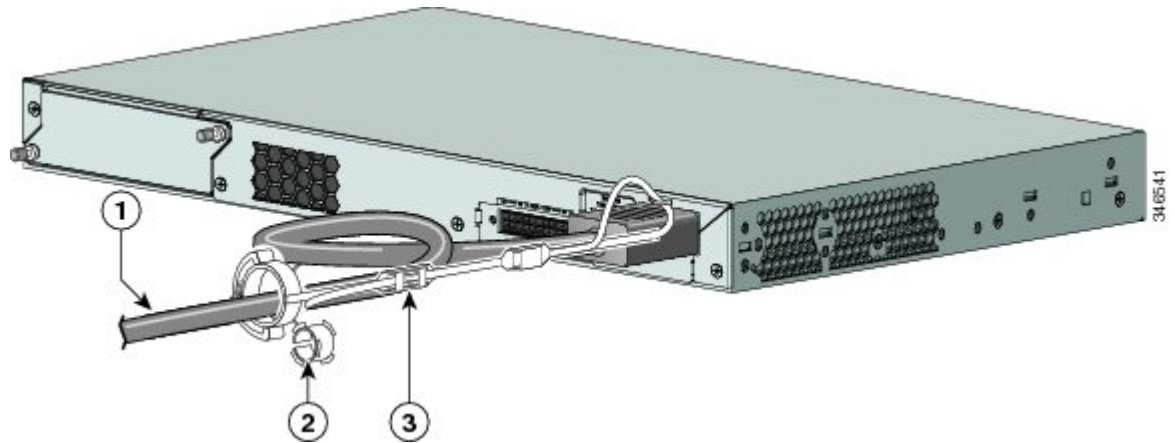

1	AC power cord	3	Latches
2	Sleeve for thin power cords		

- Step 5** (Optional) Use the small sleeve for thin power cords. Use the small sleeve to provide greater stability for thin cords. Detach the sleeve, and slide it over the power cord.

Figure 25: Sleeve Around the Power Cord

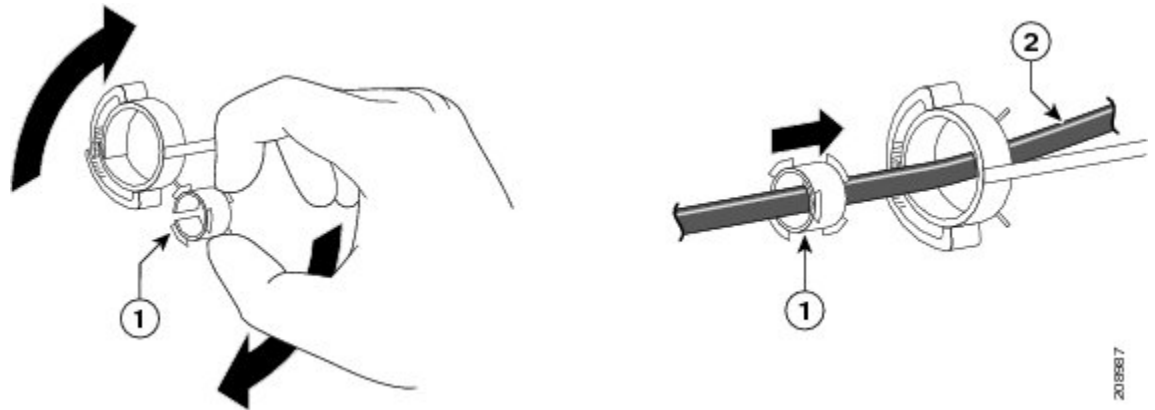

1	Sleeve for thin power cords	2	AC power cord
---	-----------------------------	---	---------------

- Step 6** Secure the AC power cord by pressing on the retainer.

Figure 26: Securing the Power Cord in the Retainer

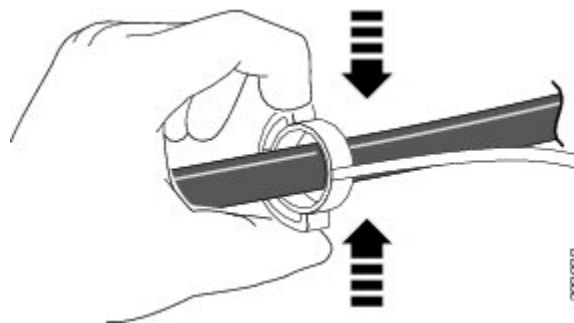

Installing SFP and SFP+ Modules

Some switch models support SFP modules, SFP+ modules, or both. The *SFP* slots support only the SFP modules. The *SFP+* slots support both SFP and SFP+ modules.

See the switch release notes on Cisco.com for the list of supported SFP modules. Use only Cisco SFP modules on the switch. Each Cisco module has an internal serial EEPROM that is encoded with security information. This encoding provides a way for Cisco to identify and validate that the module meets the requirements for the switch.

For information about installing, removing, cabling, and troubleshooting SFP modules, see the module documentation that shipped with your device.

Related Topics

[SFP and SFP+ Module Slots](#), on page 7

Installing an SFP or SFP+ Module

Before You Begin

When installing SFP or SFP+ modules, observe these guidelines:

- Do not remove the dust plugs from the modules or the rubber caps from the fiber-optic cable until you are ready to connect the cable. The plugs and caps protect the module ports and cables from contamination and ambient light.
- To prevent ESD damage, follow your normal board and component handling procedures when connecting cables to the switch and other devices.



Caution

Removing and installing an SFP or SFP+ module can shorten its useful life. Do not remove and insert any module more often than is absolutely necessary.

Procedure

- Step 1** Attach an ESD-preventive wrist strap to your wrist and to a bare metal surface.
- Step 2** Find the send (TX) and receive (RX) markings on the module top.
On some SFP or SFP+ modules, the send and receive (TX and RX) markings might be replaced by arrows that show the direction of the connection.

- Step 3** If the module has a bale-clasp latch, move it to the open, unlocked position.
- Step 4** Align the module in front of the slot opening, and push until you feel the connector snap into place.
- Step 5** If the module has a bale-clasp latch, close it.
- Step 6** For fiber-optic SFP or SFP+ modules, remove the dust plugs and save.
- Step 7** Connect the SFP cables.

Figure 27: Installing an SFP Module



Removing an SFP or SFP+ Module

Procedure

- Step 1** Attach an ESD-preventive wrist strap to your wrist and to a bare metal surface.
- Step 2** Disconnect the cable from the SFP module. For reattachment, note which cable connector plug is send (TX) and which is receive (RX).
- Step 3** Insert a dust plug into the optical ports of the SFP or SFP+ module to keep the optical interfaces clean.
- Step 4** If the module has a bale-clasp latch, pull the bale out and down to eject the module. If the latch is obstructed and you cannot use your finger, use a small, flat-blade screwdriver or other long, narrow instrument to open the latch.
- Step 5** Grasp the SFP or SFP+ module, and carefully remove it from the module slot.
- Step 6** Place the module in an antistatic bag or other protective environment.

Connecting to SFP and SFP+ Modules

Related Topics

[SFP and SFP+ Module Slots](#), on page 7

Connecting to Fiber-Optic SFP and SFP+ Modules

Warning

Class 1 laser product. Statement 1008



Caution

Do not remove the rubber plugs from the SFP or SFP+ module port or the rubber caps from the fiber-optic cable until you are ready to connect the cable. The plugs and caps protect the SFP module ports and cables from contamination and ambient light. Before connecting to the SFP module, be sure that you understand the port and cabling stipulations.

Procedure

- Step 1** Remove the rubber plugs from the module port and fiber-optic cable, and store them for future use.
- Step 2** Insert one end of the fiber-optic cable into the SFP or SFP+ module port.
- Step 3** Insert the other cable end into a fiber-optic receptacle on a target device.

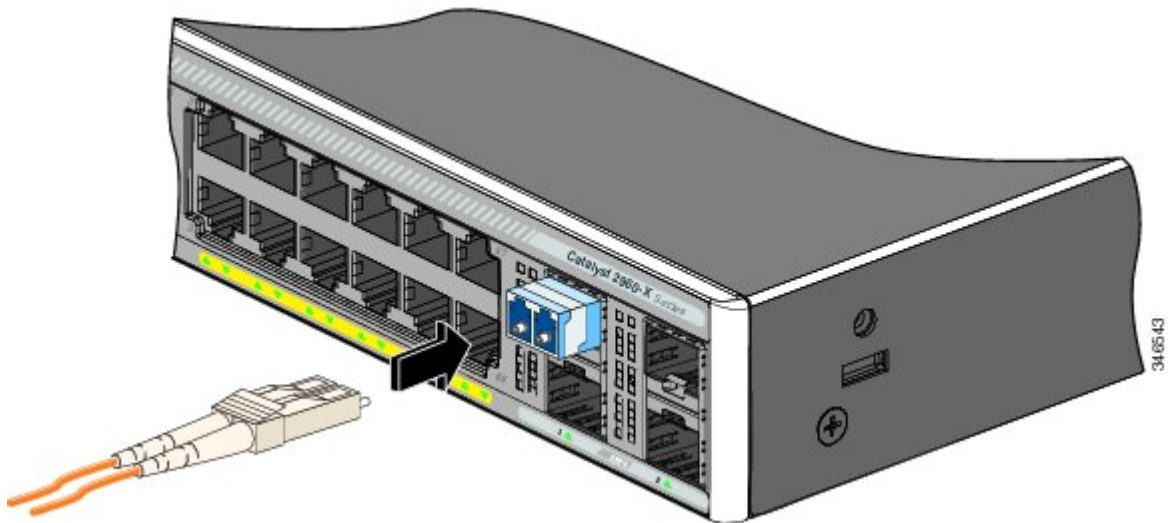
Figure 28: Connecting to a Fiber-Optic SFP Module Port



- Step 4** Observe the port status LED.

The LED turns green when the switch and the target device have an established link.

The LED turns amber while the STP discovers the network topology and searches for loops. This process takes about 30 seconds, and then the port LED turns green.

If the LED is off, the target device might not be turned on, there might be a cable problem, or there might be problem with the adapter installed in the target device.

Related Topics

[SFP Module Connectors](#), on page 78

Connecting to 1000BASE-T SFP

When connecting to a 1000BASE-T device, be sure to use a four twisted-pair, Category 5 or higher cable.

**Note**

The automatic medium-dependent interface crossover (auto-MDIX) feature is enabled by default. For configuration information for this feature, see the switch software configuration guide or the switch command reference on Cisco.com.

**Caution**

To prevent ESD damage, follow your normal board and component handling procedures.

Procedure

- Step 1** Connect one end of the cable to the SFP module port. Insert a four twisted-pair, straight-through cable when you connect to servers, workstations, and routers. Insert a four twisted-pair, crossover cable when you connect to switches or repeaters.
- Step 2** Connect the other end of the cable to an RJ-45 connector on the other device.

Figure 29: Connecting to a 1000BASE-T SFP Module

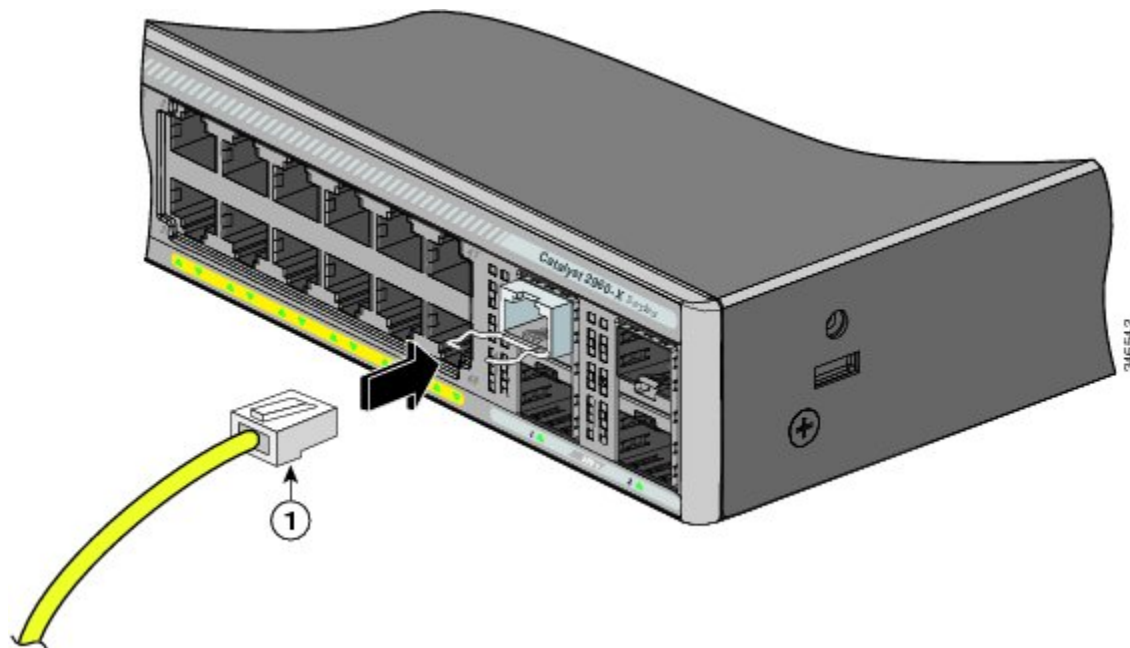

1	RJ-45 connector
---	-----------------

Step 3 Observe the port status LED.

- The LED turns green when the switch and the other device have an established link.
- The LED turns amber while the STP discovers the network topology and searches for loops. This process takes about 30 seconds, and then the port LED turns green.
- If the LED is off, the other device might not be turned on, there might be a cable problem, or there might be a problem with the adapter in the other device.

Step 4 If necessary, reconfigure and restart the switch or other device.

10/100/1000 PoE+ Port Connections

The ports provide PoE support for devices compliant with IEEE 802.3af and 802.3at (PoE+), and also provide Cisco prestandard PoE support for Cisco IP Phones and Cisco Aironet Access Points.

On a per-port basis, you can control whether or not a port automatically provides power when an IP phone or an access point is connected.

To access an advanced PoE planning tool, use the Cisco Power Calculator available on Cisco.com at this URL: <http://tools.cisco.com/cpc/launch.jsp>

You can use this application to calculate the power supply requirements for a specific PoE configuration. The results show output current, output power, and system heat dissipation.



Warning

Voltages that present a shock hazard may exist on Power over Ethernet (PoE) circuits if interconnections are made using uninsulated exposed metal contacts, conductors, or terminals. Avoid using such interconnection methods, unless the exposed metal parts are located within a restricted access location and users and service people who are authorized within the restricted access location are made aware of the hazard. A restricted access area can be accessed only through the use of a special tool, lock and key or other means of security. Statement 1072



Caution

Category 5e and Category 6 cables can store high levels of static electricity. Always ground the cables to a suitable and safe earth ground before connecting them to the switch or other devices.



Caution

Noncompliant cabling or powered devices can cause a PoE port fault. Use only standard-compliant cabling to connect Cisco prestandard IP Phones and wireless access points, IEEE 802.3af, or 802.3at (PoE+)-compliant devices. You must remove any cable or device that causes a PoE fault.

Procedure

-
- Step 1** Connect one end of the cable to the switch PoE port.
- Step 2** Connect the other end of the cable to an RJ-45 connector on the other device. The port LED turns on when both devices have established link.
The port LED is amber while STP discovers the topology and searches for loops. This process takes about 30 seconds, and then the port LED turns green. If the LED is off, the other device might not be turned on, there might be a cable problem, or there might be a problem with the adapter in the other device.
- Step 3** Reconfigure and reboot the connected device if needed.
- Step 4** Repeat Steps 1 through 3 to connect each device.
- Note** Many legacy powered devices, including older Cisco IP phones and access points that do not fully support IEEE 802.3af, might not support PoE when connected to the switches by a crossover cable.
-

10/100/1000 Port Connections

The switch 10/100/1000 port configuration changes to operate at the speed of the attached device. If the attached ports do not support autonegotiation, you can manually set the speed and duplex parameters. Connecting devices that do not autonegotiate or that have the speed and duplex parameters manually set can reduce performance or result in no linkage.

To maximize performance, choose one of these methods for configuring the Ethernet ports:

- Let the ports autonegotiate both speed and duplex.
- Set the interface speed and duplex parameters on both ends of the connection.

Auto-MDIX Connections

The autonegotiation and the auto-MDIX features are enabled by default on the switch.

With autonegotiation, the switch port configurations change to operate at the speed of the attached device. If the attached device does not support autonegotiation, you can manually set the switch interface speed and duplex parameters.

With auto-MDIX, the switch detects the required cable type for copper Ethernet connections and configures the interface accordingly.

If auto-MDIX is disabled, use the guidelines in this table to select the correct cable.

Table 15: Recommended Ethernet Cables (When Auto-MDIX is Disabled)

Device	Crossover Cable ⁹	Straight-Through Cable
Switch to switch	Yes	No
Switch to hub	Yes	No

Device	Crossover Cable ⁹	Straight-Through Cable
Switch to computer or server	No	Yes
Switch to router	No	Yes
Switch to IP phone	No	Yes

⁹ 10BASE-TX and 100BASE-T traffic requires twisted four-pair, Category 5, Category 5e, or Category 6 cable. 10BASE-T traffic can use Category 3 or Category 4 cable.

Where to Go Next

If the default configuration is satisfactory, the switch does not need further configuration. You can use any of these management options to change the default configuration:

- Start the Network Assistant application, which is described in the getting started guide. Through this GUI, you can configure and monitor a switch cluster or an individual switch.
- Use the CLI to configure the switch as a member of a cluster or as an individual switch from the console.
- Use the Cisco Prime Infrastructure application.



Power Supply Installation

This chapter applies only to the Catalyst 2960-XR switches. It contains these topics:

- [Power Supply Module Overview](#), page 53
- [Installation Guidelines](#), page 56
- [Installing or Replacing an AC Power Supply](#), page 57
- [Finding the Serial Number](#), page 59

Power Supply Module Overview

The switch operates with either one or two active power supply modules. You can use two AC modules, or one module and a blank cover.



Note

The Catalyst 2960XR-48FPD-I and 2960XR-48FPS-I only support the PWR-C2-1025WAC power supply. You cannot use the PWR-C2-250WAC and PWR-C2-640WAC power supplies in these switches.

Table 16: Power Supply Model Numbers and Description

Part Number	Description
PWR-C2-250WAC=	250-W AC power supply module
PWR-C2-640WAC=	640-W AC power supply module
PWR-C2-1025WAC=	1025-W AC power supply module

The 250-W and 640-W AC power supply modules are autoranging units that support input voltages between 100 and 240 VAC. The 1025-W power supply module is an autoranging unit that supports input voltages between 115 and 240 VAC. All power supply modules have internal fans. All switches ship with a blank cover in the second power supply slot.

Each AC power supply module has a power cord for connection to an AC power outlet.

Figure 30: PWR-C2-1025WAC Power Supply

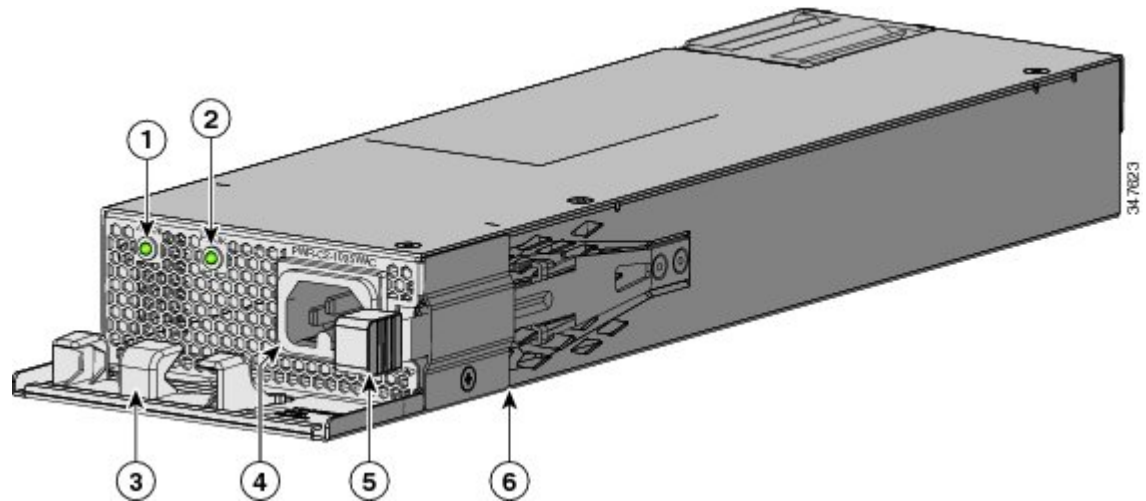

1	AC OK LED	4	AC power cord connector
2	PS OK LED	5	Release latch
3	AC power cord retainer	6	Power supply

Figure 31: PWR-C2-640WAC Power Supply

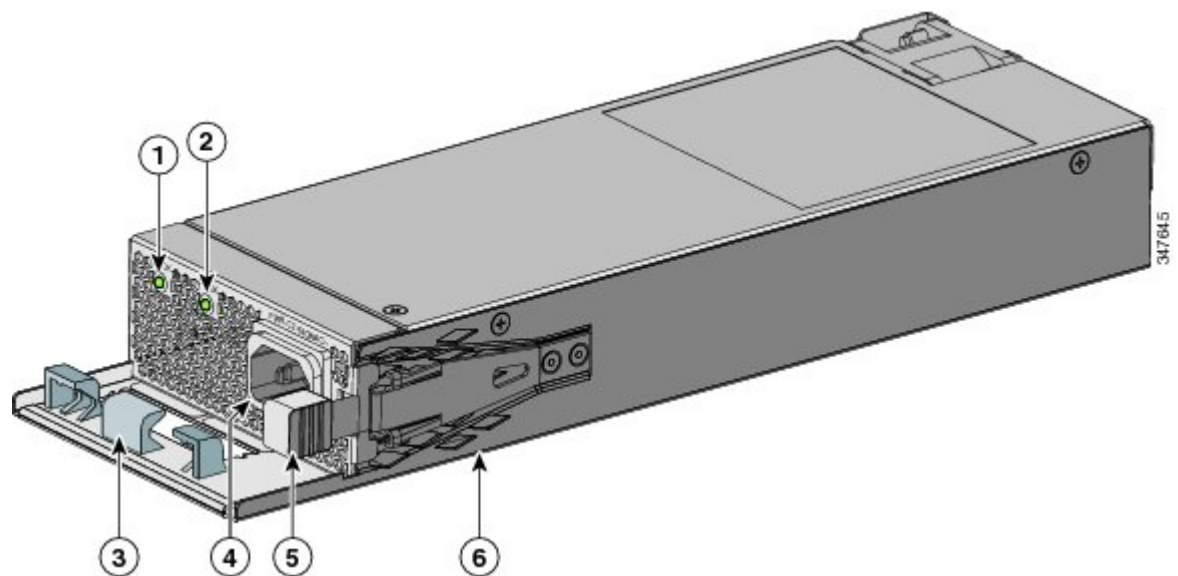

1	AC OK LED	4	AC power cord connector
---	-----------	---	-------------------------

2	PS OK LED	5	Release latch
3	AC power cord retainer	6	Power supply

Figure 32: PWR-C2-250WAC Power Supply

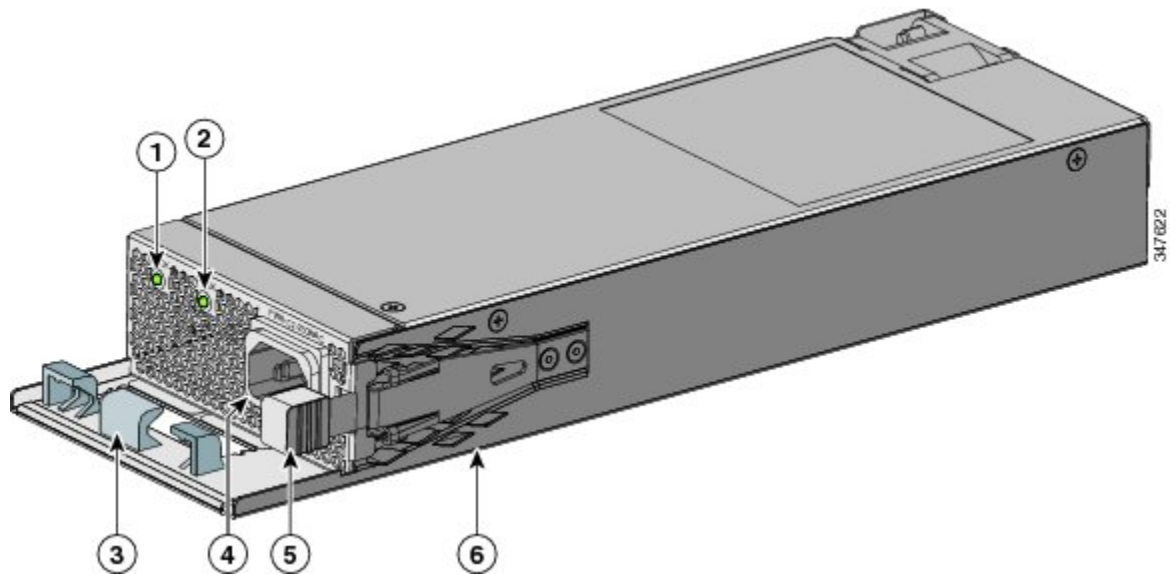

1	AC OK LED	4	AC power cord connector
2	PS OK LED	5	Release latch
3	AC power cord retainer	6	Power supply

If no power supply is installed in a power supply slot, install a power supply slot cover.

Figure 33: Power Supply Slot Cover

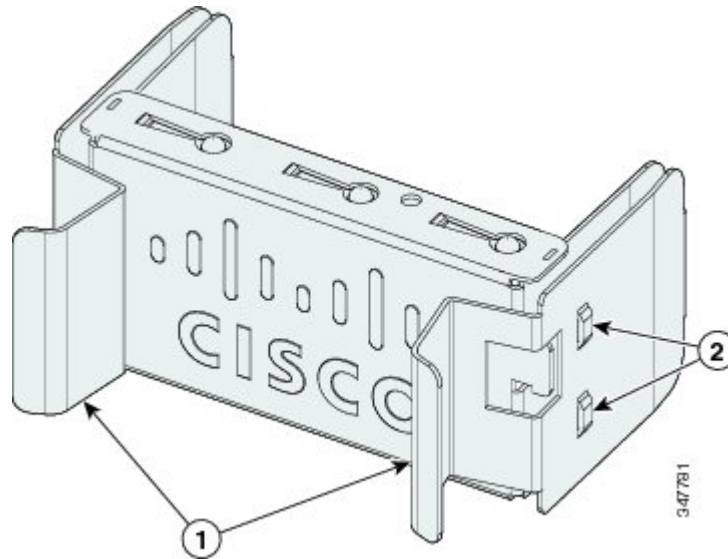

1	Release handles	2	Retainer clips
---	-----------------	---	----------------

The power supply modules have two status LEDs.

AC OK	Description	PS OK	Description
Off (AC LED is off)	No AC input power.	Off	Output is disabled, or input is outside operating range.
Green	AC input power is present.	Green	Power output to switch.
		Red	Output has failed.

Installation Guidelines

Observe these guidelines when removing or installing a power supply module:

- Do not force the power supply module into the slot. This can damage the pins on the switch if they are not aligned with the module.
- A power supply that is only partially connected to the switch can disrupt the system operation.
- Remove power from the power-supply module before removing or installing the module.

- The power supply is hot-swappable.

**Caution**

Do not operate the switch with one power-supply module slot empty. For proper chassis cooling, both module slots must be populated, with either a power supply or a blank module.

**Warning**

Blank faceplates and cover panels serve three important functions: they prevent exposure to hazardous voltages and currents inside the chassis; they contain electromagnetic interference (EMI) that might disrupt other equipment; and they direct the flow of cooling air through the chassis. Do not operate the system unless all cards, faceplates, front covers, and rear covers are in place. Statement 1024

**Warning**

Do not reach into a vacant slot or chassis while you install or remove a module. Exposed circuitry could constitute an energy hazard. Statement 206

**Warning**

Only trained and qualified personnel should be allowed to install, replace, or service this equipment. Statement 1030

**Warning**

If a Cisco external power system is not connected to the switch, install the provided connector cover on the back of the switch. Statement 386

Installing or Replacing an AC Power Supply

Procedure

- Step 1** Turn off the power at its source.
- Step 2** Remove the power cord from the power cord retainer.
- Step 3** Remove the power cord from the power connector.
- Step 4** Press the release latch at the right side of the power supply module inward and slide the power supply out.
 - Note** Do not leave the power-supply slot open for more than 90 seconds while the switch is operating.
 - Warning** This unit might have more than one power supply connection. All connections must be removed to de-energize the unit. Statement 1028

- Step 5** Insert the new power supply into the power-supply slot, and gently push it into the slot. When correctly inserted, the 250-W and 640-W power supplies (excluding the power cord retainer) are flush with the switch rear panel. The 1025-W power-supply module extends inches from the switch rear panel.

Figure 34: Inserting the AC-Power Supply in the Switch

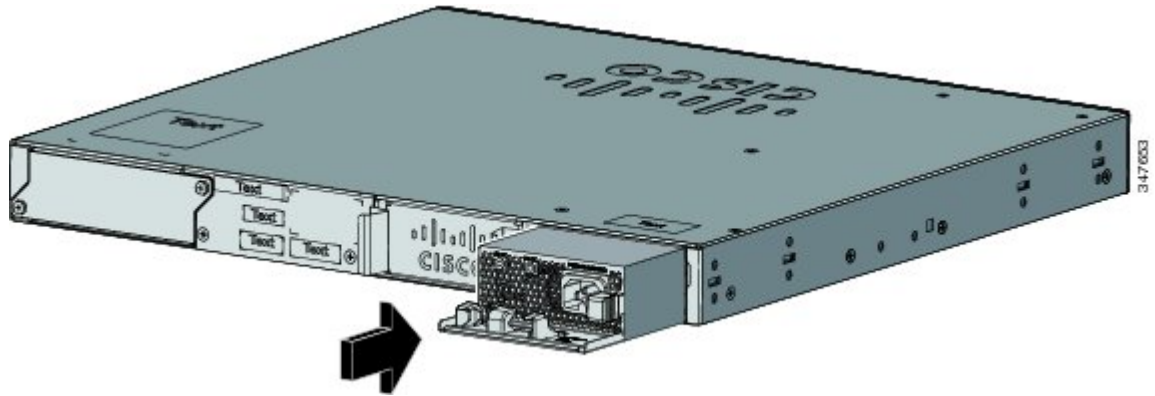

- Step 6** (Optional) Make a loop in the power cord and thread it through the power cord retainer.

Figure 35: AC-Power Supply with Power Cord Retainer

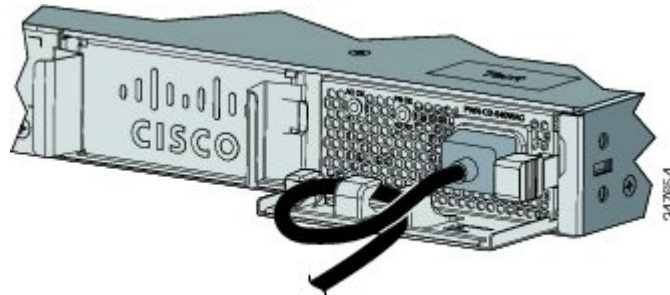

- Step 7** Connect the power cord to the power supply and to an AC power outlet. Turn on the power at the power source.
- Step 8** Confirm that the power supply AC OK and PS OK LEDs are green.
- Step 9** Repeat the steps to install a second power supply.
- Note** When you install the second power supply the LEDs on the power supply might blink momentarily.

Finding the Serial Number

If you contact Cisco Technical Assistance, you need to know the switch serial number. You can also use the `show version` privileged EXEC command to see the switch serial number.

Figure 36: 1025-W AC Power Supply Serial Number

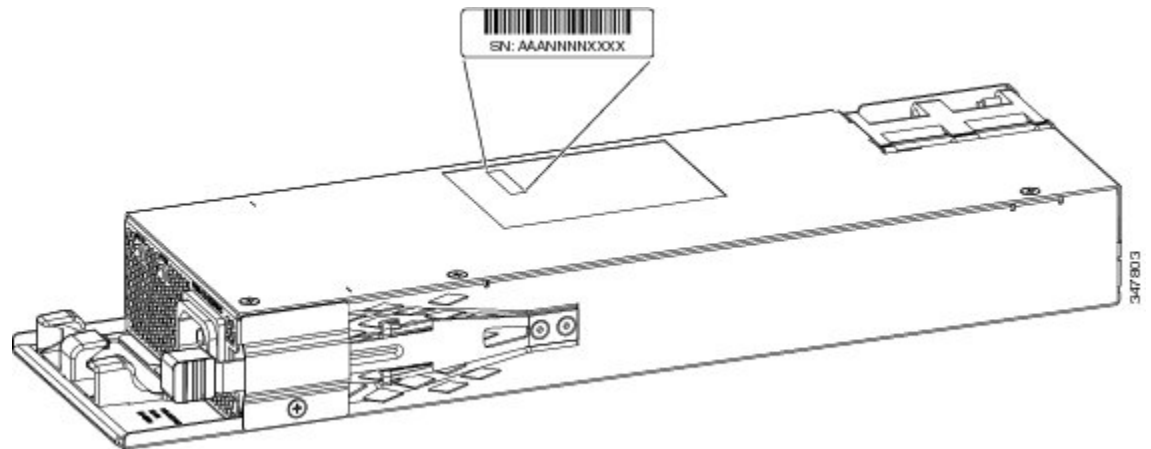
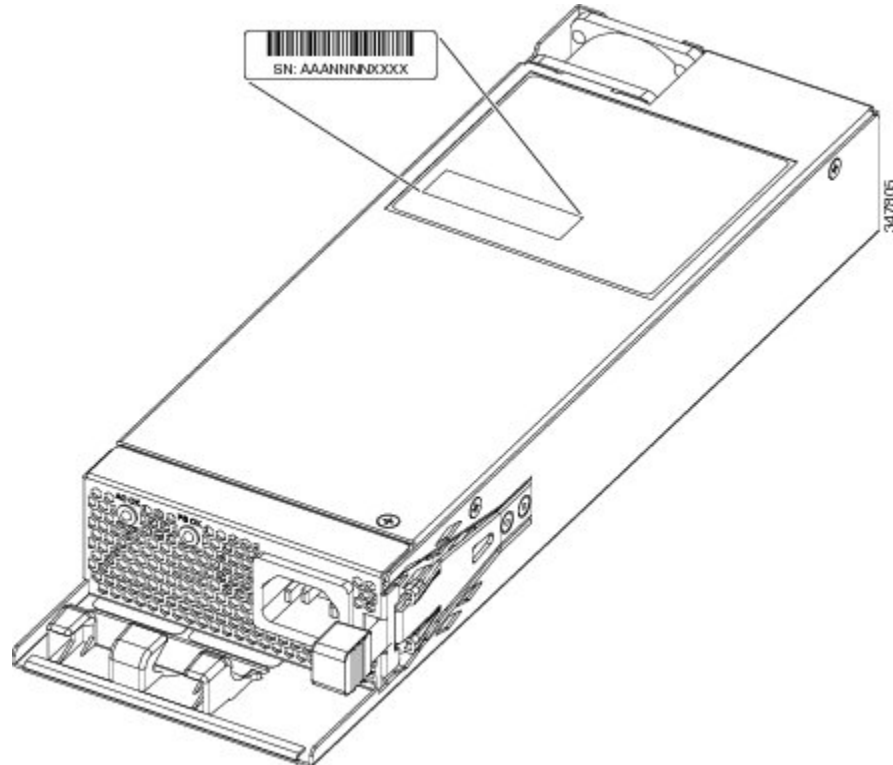

Figure 37: 250-W and 640-W AC Power Supply Serial Number





Troubleshooting

This chapter contains these topics:

- [Diagnosing Problems, page 61](#)
- [Clearing the Switch IP Address and Configuration, page 65](#)
- [Finding the Serial Number, page 66](#)
- [Replacing a Failed Stack Member, page 67](#)

Diagnosing Problems

The LEDs on the front panel provide troubleshooting information about the switch. They show POST failures, port-connectivity problems, and overall switch performance. You can also get statistics from Device Manager, from the CLI, or from an SNMP workstation.

Switch POST Results



Note

POST failures are usually fatal. Contact your Cisco technical support representative if your switch does not pass POST.

Switch LEDs

If you have physical access to the switch, look at the port LEDs for troubleshooting information about the switch. See the LED section for a description of the LED colors and their meanings.

Switch Connections

Bad or Damaged Cable

Always examine the cable for marginal damage or failure. A cable might be just good enough to connect at the physical layer, but it could corrupt packets as a result of subtle damage to the wiring or connectors. You can identify this situation because the port has many packet errors or the port constantly flaps (loses and regains link).

- Examine or exchange the copper or fiber-optic cable with a known, good cable.
- Look for broken or missing pins on cable connectors.
- Rule out any bad patch panel connections or media converters between the source and the destination. If possible, bypass the patch panel, or eliminate faulty media converters (fiber-optic-to-copper).
- Try the cable in another port or interface, if possible, to see if the problem follows the cable.
- Remove and inspect the stack cable and stack port for bent pins or damaged connectors. If the cable is bad, replace it with a known good cable.

Ethernet and Fiber-Optic Cables

Make sure that you have the correct cable for the connection.

- For Ethernet, use Category 3 copper cable for 10 Mb/s UTP connections. Use either Category 5, Category 5e, or Category 6 UTP for 10/100/1000 Mb/s connections.
- For fiber-optic cables, verify that you have the correct cable for the distance and port type. Make sure that the connected device ports both match and use the same type encoding, optical frequency, and fiber type.
- For copper connections, determine if a crossover cable was used when a straight-through was required or the reverse. Enable auto-MDIX on the switch, or replace the cable.

Link Status

Verify that both sides have link. A single broken wire or a shutdown port can cause one side to show link even though the other side does not have link.

A port LED that is on does not guarantee that the cable is fully functional. The cable might have encountered physical stress that causes it to function at a marginal level. If the port LED does not turn on:

- Connect the cable from the switch to a known good device.
- Make sure that both ends of the cable are connected to the correct ports.
- Verify that both devices have power.
- Verify that you are using the correct cable type.
- Look for loose connections. Sometimes a cable appears to be seated, but is not. Disconnect the cable and then reconnect it.

10/100/1000 Port Connections

A port appears to malfunction:

- Use the Mode button to show the status for all ports.
- Use the **show interfaces** privileged EXEC command to see if the port is error-disabled, disabled, or shutdown. Reenable the port if necessary.

10/100/1000 PoE+ Port Connections

A powered device connected to a PoE port does not receive power:

- Use the Mode button to show the PoE status for all ports.
- Use the **show interfaces** privileged EXEC command to see if the port is in error-disabled, disabled, or shutdown. Reenable the port if necessary.
- Verify that the power supply installed in the switch meets the power requirements of your connected devices.
- Verify that there is sufficient PoE power budget to provide power to the attached device. Use the **show power inline** global configuration command to check on the available PoE power budget.
- Verify the cable type. Many legacy powered devices, including older Cisco IP phones and access points that do not fully support IEEE 802.3af, might not support PoE when connected to the switch by a crossover cable. Replace the crossover cable with a straight-through cable.



Caution

Noncompliant cabling or powered devices can cause a PoE port fault. Use only standard-compliant cabling to connect Cisco prestandard IP Phones and wireless access points or IEEE 802.3af-compliant devices. You must remove any cable or device that causes a PoE fault.

SFP and SFP+ Module

Use only Cisco SFP or SFP+ modules in the switch. Each Cisco module has an internal serial EEPROM that is encoded with security information. This encoding provides a way for Cisco to identify and validate that the module meets the requirements for the switch.

- Inspect the SFP module. Exchange the suspect module with a known good module. Verify that the module is supported on this platform. (The switch release notes on Cisco.com list the SFP modules that the switch supports.)
- Use the **show interfaces** privileged EXEC command to see if the port or module is error-disabled, disabled, or shutdown. Reenable the port if needed.
- Make sure that all fiber-optic connections are properly cleaned and securely connected.

Interface Settings

Verify that the interface is not disabled or powered off. If an interface is manually shut down on either side of the link, it does not come up until you reenables the interface. Use the **show interfaces** privileged EXEC command to see if the interface is error-disabled, disabled, or shutdown on either side of the connection. If needed, reenables the interface.

Ping End Device

Ping from the directly connected switch first, and then work your way back port by port, interface by interface, trunk by trunk, until you find the source of the connectivity issue. Make sure that each switch can identify the end device MAC address in its Content-Addressable Memory (CAM) table.

Spanning Tree Loops

STP loops can cause serious performance issues that look like port or interface problems.

A unidirectional link can cause loops. It occurs when the traffic sent by the switch is received by its neighbor, but the traffic from the neighbor is not received by the switch. A broken fiber-optic cable, other cabling problems, or a port issue could cause this one-way communication.

You can enable UniDirectional Link Detection (UDLD) on the switch to help identify unidirectional link problems.

Switch Performance

Speed, Duplex, and Autonegotiation

If the port statistics show a large amount of alignment errors, frame check sequence (FCS), or late-collisions errors, this might mean a speed or duplex mismatch.

A common issue with speed and duplex occurs when duplex and speed settings are mismatched between two switches, between a switch and a router, or between the switch and a workstation or server. Mismatches can happen when manually setting the speed and duplex or from autonegotiation issues between the two devices.

To maximize switch performance and to ensure a link, follow one of these guidelines when changing the duplex or the speed settings.

- Let both ports autonegotiate both speed and duplex.
- Manually set the speed and duplex parameters for the interfaces on both ends of the connection.
- If a remote device does not autonegotiate, use the same duplex settings on the two ports. The speed parameter adjusts itself even if the connected port does not autonegotiate.

Autonegotiation and Network Interface Cards

Problems sometimes occur between the switch and third-party network interface cards (NICs). By default, the switch ports and interfaces autonegotiate. Laptops or other devices are commonly set to autonegotiate, yet sometimes autonegotiation issues occur.

To troubleshoot autonegotiation problems, try manually setting both sides of the connection. If this does not solve the problem, there could be a problem with the firmware or software on your NIC. You can resolve this by upgrading the NIC driver to the latest version.

Cabling Distance

If the port statistics show excessive FCS, late-collision, or alignment errors, verify that the cable distance from the switch to the connected device meets the recommended guidelines.

Clearing the Switch IP Address and Configuration

If you have configured a new switch with a wrong IP address, or if all of the switch LEDs start blinking when you are trying to enter Express Setup mode, you can clear the configured IP address. The switch returns to the factory default settings.

**Note**

This procedure clears the IP address and all configuration information stored on the switch. Do not follow this procedure unless you want to completely reconfigure the switch.

Procedure

- Step 1** Press and hold the Mode button. The switch LEDs blink after about 2 seconds. If the switch is not configured, the LEDs above the Mode button turn green. You can omit the next step.
- Step 2** Continue holding down the Mode button. The LEDs stop blinking after 8 seconds, and then the switch reboots. You can now configure the switch by using Express Setup as described in the switch getting started guide. You can also configure the switch by using the CLI setup procedure described in the appendix.
-

Finding the Serial Number

If you contact Cisco Technical Assistance, you need to know the switch serial number. You can also use the `show version` privileged EXEC command to see the switch serial number.

Figure 38: Serial Number Location for the Catalyst 2960-X Switches

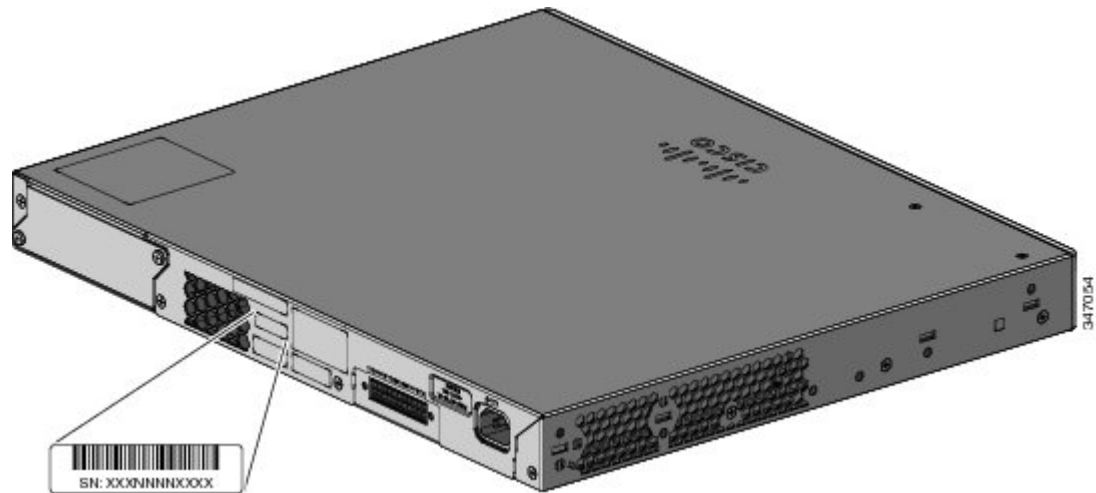

Figure 39: Serial Number Location for the FlexStack-Plus Module

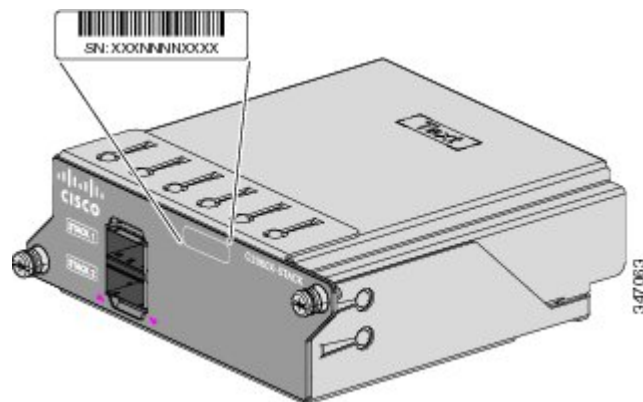
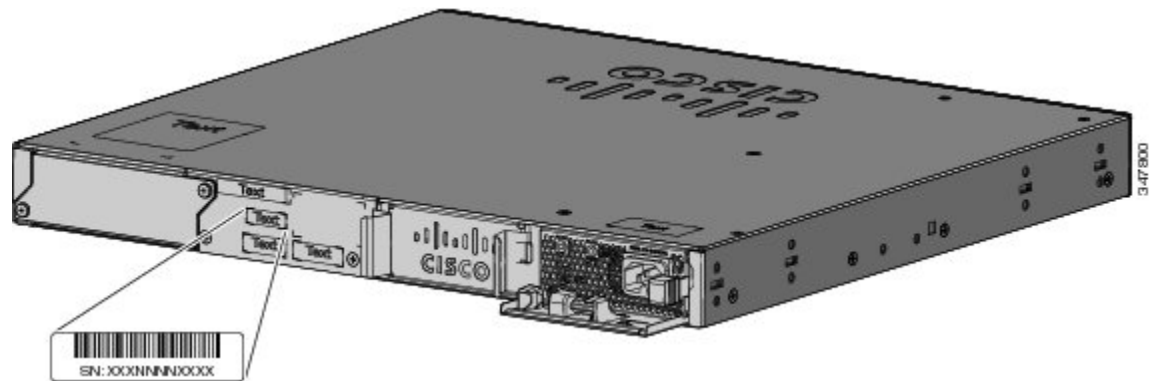

Figure 40: Serial Number Location for the Catalyst 2960-XR Switches



Replacing a Failed Stack Member

Procedure

- Step 1** Get a replacement switch that has the same model number as the failed switch.
- Step 2** Power down the failed switch.
- Step 3** Make sure that the replacement switch is off and that the FlexStack-Plus module is installed.
- Step 4** Connect the switch to the stack.
- Step 5** Make the same connections on the replacement switch that were on the failed switch.
- Step 6** Reinstall any modules, and make cable connections.
- Step 7** Power on the replacement switch.
The replacement switch has the same configuration for all the interfaces as the failed switch and functions the same as the failed switch.

If you had manually set the member numbers for any stack members, you need to manually assign the replacement switch with the same member number as the failed switch. See the *Catalyst 2960-X Switch Stacking Command Reference* on Cisco.com.



Technical Specifications

This appendix contains these topics:

- [Environmental Specifications, page 69](#)
- [Specifications for the Catalyst 2960-X Switches, page 70](#)
- [Specifications for the Catalyst 2960-XR Switches, page 74](#)

Environmental Specifications

This table describes the environmental specifications.

Table 17: Environmental Specifications for All Catalyst 2960-X and 2960-XR Switches

Environmental Ranges	
Operating temperature 10	23 to 113°F (–5 to 45°C) up to 5,000 ft (1500 m) 23 to 104°F (–5 to 40°C) up to 10,000 ft (3000 m)
Storage temperature	–40 to 158°F (–40 to 70°C) up to 15,000 ft (4500 m)
Relative humidity	10 to 95% (noncondensing)
Storage altitude	Up to 15,000 ft (4500 m)

¹⁰ Minimum ambient temperature for cold start is 32°F (0°C)

Table 18: Environmental and Physical Specification for the AC Power Supplies for the Catalyst 2960-XR Switches

Power Requirements	
Operating temperature	23 to 113°F (–5 to 45°C)
Storage temperature	–40 to 158°F (–40 to 70°C)

Relative humidity	10-95% (non-condensing)
Altitude	Up to 10,000 ft (3,000 m)
Weight	<ul style="list-style-type: none"> • PWR-C2-250WAC: 2.5 lb (1.1 kg) • PWR-C2-640WAC: 3.1 lb (1.4 kg) • PWR-C2-1025WAC: 3.4 lb (1.6 kg)
Dimensions	<ul style="list-style-type: none"> • PWR-C2-250WAC: 1.58 x 10.22 x 3.75 in. (3.5 x 26 x 9.53 cm) • PWR-C2-640WAC: 1.58 x 10.22 x 3.75 in. (3.5 x 26 x 9.53 cm) • PWR-C2-1025WAC: 1.58 x 11.72 x 3.75 in. (3.5 x 29.8 x 9.53 cm) <p>Note Dimensions shown exclude the extraction handle, which measures 1.55 in. (3.9 cm).</p>

Specifications for the Catalyst 2960-X Switches

Table 19: Catalyst 2960X-48FPD-L, 2960X-48LPD-L, 2960X-24PD-L, 2960X-48FPS-L, 2960X-48LPS-L, 2960X-24PSQ-L, and 2960X-24PS-L Switch Specifications

Power Requirements	
AC input voltage	100 to 240 VAC (autoranging) <ul style="list-style-type: none"> • 9 to 4 A, 50 to 60 Hz (Catalyst 2960X-48FPD-L) • 5 to 2 A, 50 to 60 Hz (Catalyst 2960X-48LPD-L) • 5 to 2 A, 50 to 60 Hz (Catalyst 2960X-24PD-L) • 9 to 4 A, 50 to 60 Hz (Catalyst 2960X-48FPS-L) • 5 to 2 A, 50 to 60 Hz (Catalyst 2960X-48LPS-L) • 5 to 2 A, 50 to 60 Hz (Catalyst 2960X-24PS-L) • 2 to 4 A, 50 to 60 Hz (Catalyst 2960X-24PSQ-L)

<p>DC input voltage for RPS 2300</p>	<ul style="list-style-type: none"> • +12 V @ 4 A, -53 V @ 15 A (Catalyst 2960X-48FPD-L) • +12 V @ 4 A, -53 V @ 8 A (Catalyst 2960X-48LPD-L) • +12 V @ 3A, -53 V @ 8 A (Catalyst 2960X-24PD-L) • 12 V @ 4 A, -53 V @ 15 A (Catalyst 2960X-48FPS-L) • +12 V @ 4 A, -53 V @ 8 A (Catalyst 2960X-48LPS-L) • +12 V @ 3 A, -53 V @ 8 A (Catalyst 2960X-24PS-L) <p>Note The Catalyst 2960X-24PSQ-L does not support the RPS 2300</p>
<p>Power consumption¹¹</p>	<ul style="list-style-type: none"> • 149 W, 508 BTUs per hour (Catalyst 2960X-48FPD-L) • 103 W, 351 BTUs per hour (Catalyst 2960X-48LPD-L) • 92 W, 313 BTUs per hour (Catalyst 2960X-24PD-L) • 149 W, 508 BTUs per hour (Catalyst 2960X-48FPS-L) • 102 W, 348 BTUs per hour (Catalyst 2960X-48LPS-L) • 90 W, 307 BTUs per hour (Catalyst 2960X-24PS-L) • 34.8 W, 119 BTUs per hour (Catalyst 2960X-24PSQ-L)
<p>Power rating¹²</p>	<ul style="list-style-type: none"> • 0.89 KVA (Catalyst 2960X-48FPD-L) • 0.48 KVA (Catalyst 2960X-48LPD-L) • 0.47 KVA (Catalyst 2960X-24PD-L) • 0.89 KVA (Catalyst 2960X-48FPS-L) • 0.49 KVA (Catalyst 2960X-48LPS-L) • 0.49 KVA (Catalyst 2960X-24PS-L) • 0.16 KVA (Catalyst 2960X-24PSQ-L)
<p>PoE+</p>	
<ul style="list-style-type: none"> • 30 W-per-port maximum, 740-W switch maximum (Catalyst 2960X-48FPD-L and 2960X-48FPS-L switches) • 15.4 W-per-port maximum, 370-W switch maximum (Catalyst 2960X-48LPD-L, 2960X-24PD-L, 2960X-48LPS-L, and 2960X-24PS-L switches) <p>Note The Catalyst 2960X-48LPD-L and 2960X-48LPS-L can support up to 12 ports of PoE+ (30 W-per-port).</p> <ul style="list-style-type: none"> • 30 W-per-port maximum, 110-W switch maximum (Catalyst 2960X-24PSQ-L switch) 	

Physical Dimensions	
Weight	<ul style="list-style-type: none"> • 12.9 lb (5.8 kg) (Catalyst 2960X-48FPD-L) • 12.8 lb (5.8 kg) (Catalyst 2960X-48LPD-L) • 12.7 lb (5.8 kg) (Catalyst 2960X-24PD-L) • 13.2 (6.0 kg) (Catalyst 2960X-48FPS-L) • 12.9 lb (5.8 kg) (Catalyst 2960X-48LPS-L) • 12.8 lb (5.8 kg) (Catalyst 2960X-24PS-L) • 12.8 lb (5.8 kg) (Catalyst 2960X-24PSQ-L)
Dimensions (H x D x W)	<p>1.75 x 14.50 x 17.5 in. (4.45 x 36.83 x 44.5 cm). Applies to all PoE switches except the Catalyst 2960X-24PSQ-L switch.</p> <p>1.75 x 11.02 x 17.5 in. (4.45 x 28.0 x 44.5 cm). Applies to the Catalyst 2960X-24PSQ-L switch.</p>

- ¹¹ Power consumption values for the power consumed internally by the switch at 120 VAC 60 Hz. The information is based on the rating of the power supply (maximum) and does not reflect the actual measured consumption numbers. For the actual power consumption based on measurement, see the data sheet at: http://www.cisco.com/en/US/prod/collateral/switches/ps5718/ps12995/data_sheet_c78-728232.html
- ¹² Power rating values for the switch input power.

Table 20: Catalyst 2960X-48TD-L, 2960X-24TD-L, 2960X-48TS-L, 2960X-24TS-L, 2960X-48TS-LL, 2960X-F24TS-LL, Switch Specifications

Power Requirements	
AC input voltage	<p>100 to 240 VAC (autoranging)</p> <ul style="list-style-type: none"> • 1 to 0.5 A, 50 to 60 Hz (Catalyst 2960X-48TD-L) • 1 to 0.5 A, 50 to 60 Hz (Catalyst 2960X-24TD-L) • 1 to 0.5, 50 to 60 Hz (Catalyst 2960X-48TS-L) • 1 to 0.5 A, 50 to 60 Hz (Catalyst 2960X-24TS-L) • 1 to 0.5 A, 50 to 60 Hz (Catalyst 2960X-48TS-LL) • 1 to 0.5 A,, 50 to 60 Hz (Catalyst 2960X-24TS-LL)
DC input voltage for RPS 2300	<ul style="list-style-type: none"> • +12 V @ 4 A, -53 V @ 8 A (Catalyst 2960X-48TD-L) • +12 V @ 3 A, (Catalyst 2960X-24TD-L) • +12 V @ 5 A, (Catalyst 2960X-48TS-L) • +12 V @ 4 A, (Catalyst 2960X-24TS-L)

Power consumption ¹³	<ul style="list-style-type: none"> • 47 W, 161 BTUs per hour (Catalyst 2960X-48TD-L) • 32 W, 110 BTUs per hour (Catalyst 2960X-24TD-L) • 49 W, 168 BTUs per hour (Catalyst 2960X-48TS-L) • 37 W, 126 BTUs per hour (Catalyst 2960X-24TS-L) • 55 W, 187 BTUs per hour (Catalyst 2960X-48TS-LL) • 37 W, 126 BTUs per hour (Catalyst 2960X-24TS-LL)
Power rating ¹⁴	<ul style="list-style-type: none"> • 0.049 KVA (Catalyst 2960X-48TD-L) • 0.034 KVA (Catalyst 2960X-24TD-L) • 0.051 KVA (Catalyst 2960X-48TS-L) • 0.039 KVA (Catalyst 2960X-24TS-L) • 0.46 KVA (Catalyst 2960X-48TS-LL) • 0.035 KVA (Catalyst 2960X-24TS-LL)
<p>Physical Dimensions</p>	
Weight Dimensions (H x D x W)	9.6 lb (4.3 kg) Catalyst 2960X-48TD-L 8.9 lb (4.0 kg) Catalyst 2960X-24TD-L 9.4 lb (4.2 kg) Catalyst 2960X-48TS-L 8.9 lb (4.0 kg) Catalyst 2960X-24TS-L 8.9 lb (4.0 kg) Catalyst 2960X-48TS-LL 8.2 lb (3.7 kg) Catalyst 2960X-24TS-LL
1.75 x 11 x 17.50 in. (4.45 x 27.94 x 44.5 cm) All non-PoE switches.	

¹³ Power consumption values for the power consumed internally by the switch at 120 VAC 60 Hz. The information is based on the rating of the power supply (maximum) and does not reflect the actual measured consumption numbers. For the actual power consumption based on measurement, see the data sheet at: http://www.cisco.com/en/US/prod/collateral/switches/ps5718/ps12995/data_sheet_c78-728232.html

¹⁴ Power rating values for the switch input power.

Specifications for the Catalyst 2960-XR Switches

Table 21: Physical Specifications for the Catalyst 2960-XR Switches

Physical Dimensions	
Weight	<ul style="list-style-type: none"> • 3.55 lb (1.61 kg) • 3.1 lb (1.41 kg) • 2.55 lb (1.16 kg) • 2.75 lb (1.25 kg) • 0.2 lb (0.09 kg) <p>Weights do not include power supplies.</p>
Dimensions (H x D x W)	<p>1.75 x 16.1 x 17.5 in. (4.45 x 41.9 x 44.5 cm)</p> <p>Dimensions do not include power supplies.</p> <ul style="list-style-type: none"> • Add an additional depth of 1.6 in (4.1 cm) for PWR-C2-250WAC and PWR-C2-640WAC power supplies • Add an additional depth of 3.1 in (7.9 cm) for the PWR-C2-1025WAC power supply

Table 22: Power Specifications for the AC Power Catalyst 2960-XR Switches

Power Requirements	
Maximum output power	<ul style="list-style-type: none"> • PWR-C2-250WAC: 250 W • PWR-C2-640WAC: 640 W • PWR-C2-1025WAC: 1025 W
Input voltage and Frequency	<ul style="list-style-type: none"> • PWR-C2-250WAC: 250 W, 100-240 VAC, (autoranging) 50-60 Hz • PWR-C2-640WAC: 640 W, 100-240 VAC, (autoranging) 50-60 Hz • PWR-C2-1025WAC: 1025 W, 115-240 VAC, (autoranging) 50-60 Hz

Input current 15	<ul style="list-style-type: none"> • PWR-C2-250WAC: 4–2 A • PWR-C2-640WAC: 8–4 A • PWR-C2-1025WAC: 12–6 A
Output ratings	<ul style="list-style-type: none"> • PWR-C2-250WAC: +12 V @ 20.83 A • PWR-C2-640WAC: +12 V @ 20.83 A, –54 V@7.36 A • PWR-C2-1025WAC: +12 V @ 20.83 A, –54 V@14.6 A
Total input BTU ¹⁶	<ul style="list-style-type: none"> • PWR-C2-250WAC: 945 BTUs per hour, 277 W • PWR-C2-640WAC: 2371 BTUs per hour, 695 W • PWR-C2-1025WAC: 3801 BTUs per hour, 1114 W
Total output BTU ¹	<ul style="list-style-type: none"> • PWR-C2-250WAC: 853 BTUs per hour, 250 W • PWR-C2-640WAC: 2183 BTUs per hour, 640 W • PWR-C2-1025WAC: 3497 BTUs per hour, 1025 W

¹⁵ The information is based on the rating of the power supply (max.) and does not reflect the actual measured consumption numbers. For the actual power consumption based on measurement, see the data sheet at: http://www.cisco.com/en/US/prod/collateral/switches/ps5718/ps12995/data_sheet_c78-728232.html

¹⁶ The total input and total output BTU ratings refer to input power to the power supply and output power to the switch. The BTU ratings are based on 100 VAC for the 250-W and 640-W power supplies and 115 VAC for the 1025-W power supply .

Table 23: Power Supply Module Specifications

Physical Dimensions	
Weight PWR-C2-1025WAC= PWR-C2-640WAC= PWR-C2-250WAC= PWR-C2-BLANK=	<ul style="list-style-type: none"> • 3.55 lb (1.61 kg) • 3.1 lb (1.41 kg) • 2.55 lb (1.16 kg) • 0.2 lb (0.09 kg) <p>Weights do not include power supplies.</p>
Dimensions (H x W x D) PWR-C2-1025WAC PWR-C2-640WAC PWR-C2-250WAC	<ul style="list-style-type: none"> • 1.58 x 3.75 x 13.25 in. (4.0 x 9.5 x 33.7 cm) • 1.58 x 3.75 x 11.75 in. (4.0 x 9.5 x 29.8 cm) • 1.58 x 3.75 x 11.75 in. (4.0 x 9.5 x 29.8 cm)

Recommendations

- An additional 10.3 in. depth is required behind the power supply handle for power supply removal
- An additional 1.5 in. depth is required behind the power supply for power cord bend radius
- An additional 4.7 in. depth is required behind the chassis rear for stack module removal
- An additional 5.2 in. depth is required behind the chassis rear for stack cable bend radius



Connector and Cable Specifications

This appendix contains these topics:

- [Connector Specifications, page 77](#)
- [Cables and Adapters, page 78](#)

Connector Specifications

10/100/1000 Ports (Including PoE)

All 10/100/1000 ports use standard RJ-45 connectors and Ethernet pinouts.

Figure 41: 10/100/1000 Port Pinouts

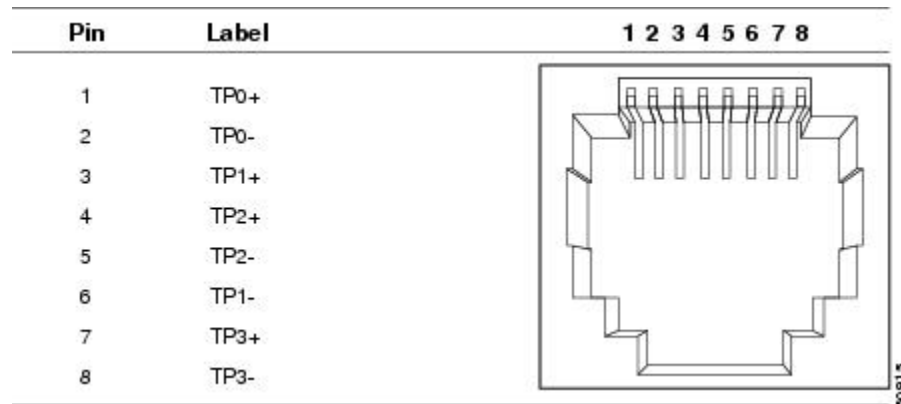

SFP Module Connectors

Figure 42: Duplex LC Cable Connector



Figure 43: Simplex LC Cable Connector

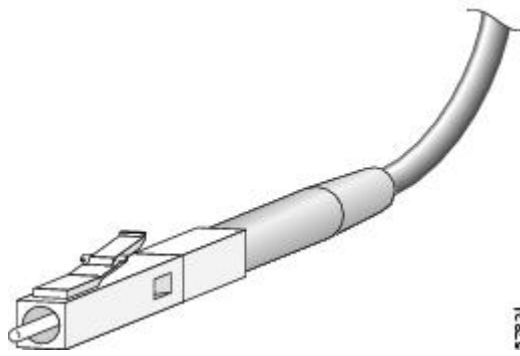

Figure 44: Copper SFP Module LC Connector

Pin	Label	1	2	3	4	5	6	7	8
1	TP0+								
2	TP0-								
3	TP1+								
4	TP2+								
5	TP2-								
6	TP1-								
7	TP3+								
8	TP3-								

Cables and Adapters

SFP Module Cables

For cabling specifications, refer to the following notes:

- [Cisco SFP and SFP+ Transceiver Module Installation Notes](#)
- [Cisco 40-Gigabit QSFP+ Transceiver Modules Installation Note](#)

Each port must match the wave-length specifications on the other end of the cable, and the cable must not exceed the stipulated cable length. Copper 1000BASE-T SFP module transceivers use standard four twisted-pair, Category 5 cable at lengths up to 328 feet (100 meters).

Cable Pinouts

Figure 45: Four Twisted-Pair Straight-Through Cable Schematic

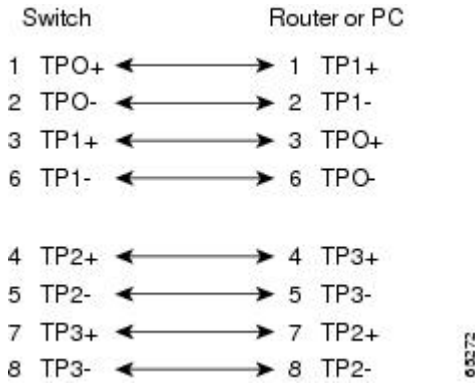

Figure 46: Four Twisted-Pair Semi-Cross Cable Schematic

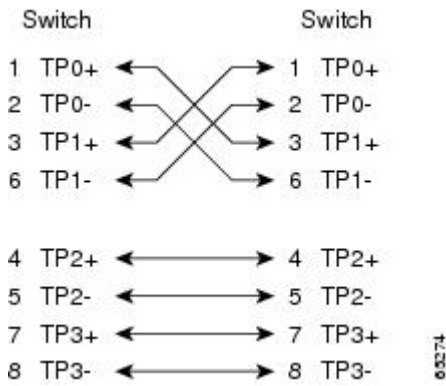

Figure 47: Two Twisted-Pair Straight-Through Cable Schematic

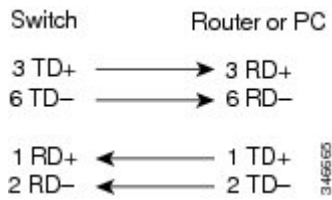
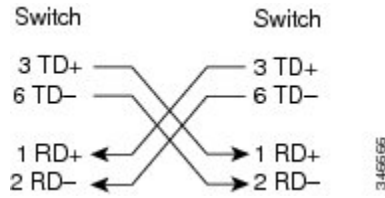

Figure 48: Two Twisted-Pair Crossover Cable Schematic



Identifying a Crossover Cable

To identify a crossover cable, compare the two modular ends of the cable. Hold the cable ends side-by-side, with the tab at the back. The wire connected to the pin on the outside of the left plug should be a different color from the wire connected to the pin on the inside of the right plug.

Figure 49: Identifying a Crossover Cable

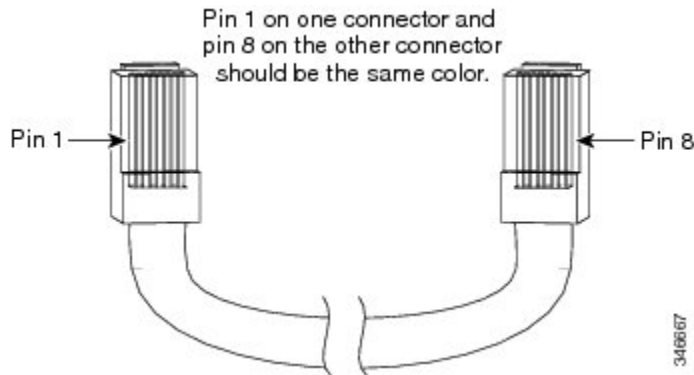

Console Port Adapter Pinouts

The RS-232 console port uses an 8-pin RJ-45 connector. Use an RJ-45-to-DB-9 adapter cable to connect the switch console port to a console PC. You need to provide a RJ-45-to-DB-25 female DTE adapter to connect the switch console port to a terminal. You can order the kit (part number ACS-DSBUASYN=) from Cisco.

Table 24: Console Port Signaling with a DB-9 Adapter

Switch Console Port (DTE)	RJ-45-to-DB-9 Terminal Adapter	Console Device
Signal	DB-9 Pin	Signal
RTS	8	CTS
DTR	6	DSR
TxD	2	RxD
GND	5	GND
GND	5	GND

Switch Console Port (DTE)	RJ-45-to-DB-9 Terminal Adapter	Console Device
Signal	DB-9 Pin	Signal
RxD	3	TxD
DSR	4	DTR
CTS	7	RTS

Table 25: Console Port Signaling with a DB-25 Adapter

Switch Console Port (DTE)	RJ-45-to-DB-25 Terminal Adapter	Console Device
Signal	DB-25 Pin	Signal
RTS	5	CTS
DTR	6	DSR
TxD	3	RxD
GND	7	GND
GND	7	GND
RxD	2	TxD
DSR	20	DTR
CTS	4	RTS



Configuring the Switch with the CLI-Based Setup Program

This appendix contains these topics:

- [Accessing the CLI Through Express Setup, page 83](#)
- [Accessing the CLI Through the Console Port, page 83](#)
- [Entering the Initial Configuration Information, page 89](#)

Accessing the CLI Through Express Setup

You can access the CLI on an unconfigured switch. Set the switch in Express Setup mode and connect a switch Ethernet port to an Ethernet port on your PC or workstation. Follow the steps described in the getting started guide for turning on the switch and using Express Setup.

When the switch is in Express Setup mode, open a Telnet session to the switch by entering the IP address 10.0.0.1. Enter the **setup** user EXEC command. Enter the information described in [IP Settings, on page 89](#) and [Completing the Setup Program, on page 89](#).

After you have entered the configuration information for the switch, save it to flash memory by using the **write memory** privileged EXEC command.

**Note**

In Express Setup mode, the IP address 10.0.0.1 remains active on the switch until you enter the **write memory** command. You lose the Telnet connection after entering the **write memory** command.

Accessing the CLI Through the Console Port

You can access the CLI on a configured or unconfigured switch by connecting the RJ-45 console port or USB console port of the switch to your PC or workstation and accessing the switch through a terminal emulation program.

**Note**

If you have stacked your switches, connect to the console port of one of the switches in the stack. You can initially configure the entire stack from any member switch.

Connecting the RJ-45 Console Port

Procedure

- Step 1** Connect the RJ-45-to-DB-9 adapter cable to the 9-pin serial port on the PC. Connect the other end of the cable to the switch console port.
- Step 2** Start the terminal-emulation program on the PC or the terminal. The program, frequently a PC application such as HyperTerminal or ProcommPlus, makes communication between the switch and your PC or terminal possible.
- Step 3** Configure the baud rate and character format of the PC or terminal to match the console port default characteristics:
- 9600 baud
 - 8 data bits
 - 1 stop bit
 - No parity
 - None (flow control)
- Step 4** Power on the switch as described in the switch getting started guide.
- Step 5** The PC or terminal displays the bootloader sequence. Press **Enter** to display the setup prompt. Follow the steps in [Entering the Initial Configuration Information](#), on page 89.
-

Connecting the USB Console Port

Procedure

Step 1 If you are connecting the switch USB console port to a Windows-based PC for the first time, install the USB driver. See [Installing the Cisco Microsoft Windows USB Device Driver](#), on page 86.

Figure 50: Connecting the USB Console Cable to the Switch

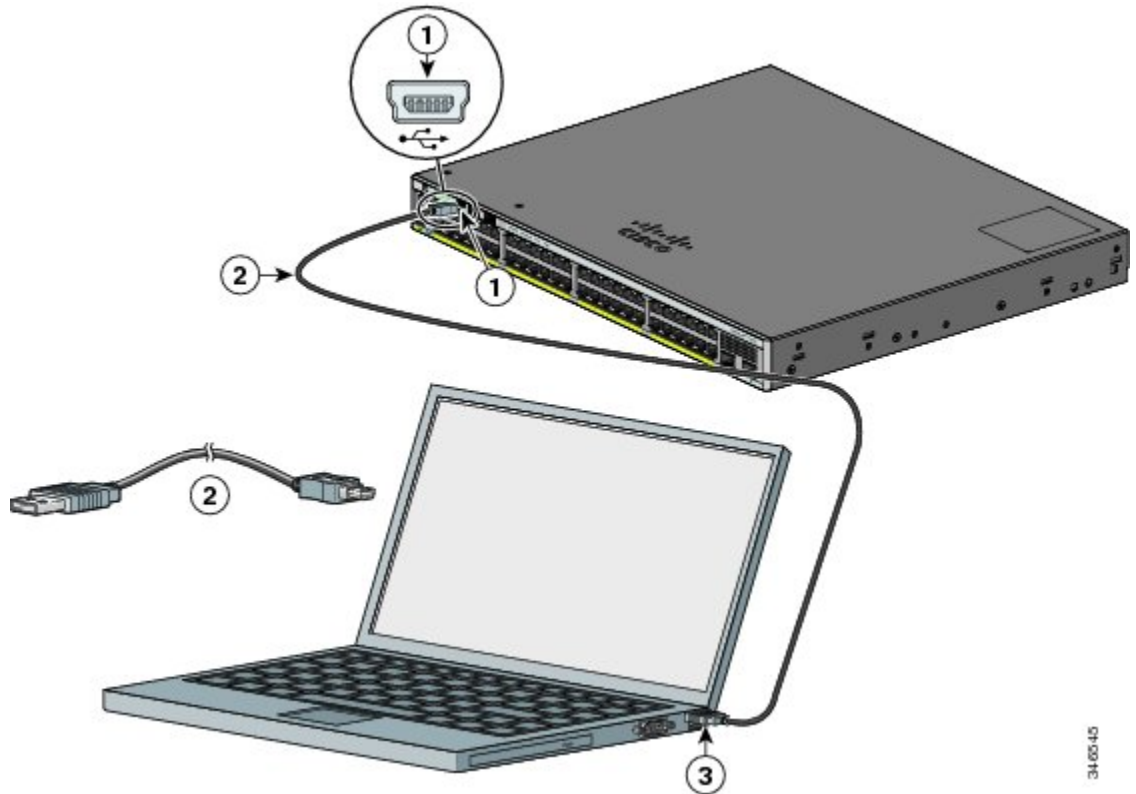

1	USB console port (5-pin mini-Type B)	3	USB Type A connection on the laptop
2	USB Type A to 5-pin mini-Type B cable		

- Step 2** Connect a USB cable to the PC USB port. Connect the other end of the cable to the switch mini-B (5-pin-connector) USB console port.
- Step 3** Start the terminal-emulation program on the PC or the terminal. The program, frequently a PC application such as HyperTerminal or ProcommPlus, makes communication between the switch and your PC or terminal possible.
- Step 4** Configure the baud rate and character format of the PC or terminal to match the console port default characteristics:

- 9600 baud
- 8 data bits
- 1 stop bit
- No parity
- None (flow control)

Step 5 Power on the switch as described in the switch getting started guide.

Step 6 The PC or terminal displays the bootloader sequence. Press **Enter** to display the setup prompt. Follow the steps in the Setup program.

Installing the Cisco Microsoft Windows USB Device Driver

A USB device driver must be installed the first time a Microsoft Windows-based PC is connected to the USB console port on the switch.

- [Installing the Cisco Microsoft Windows XP USB Driver](#)
- [Installing the Cisco Microsoft Windows 2000 USB Driver](#)
- [Installing the Cisco Microsoft Windows Vista and Windows 7 USB Driver](#)

Installing the Cisco Microsoft Windows XP USB Driver

Procedure

Step 1 Obtain the Cisco USB console driver file from the Cisco.com web site and unzip it.

Note You can download the driver file from the Cisco.com site for downloading the switch software.

Step 2 If using 32-bit Windows XP, double-click the setup.exe file in the Windows_32 folder. If using 64-bit Windows XP, double-click the setup(x64).exe file in the Windows_64 folder.

Step 3 The Cisco Virtual Com InstallShield Wizard begins.

Step 4 The Ready to Install the Program window appears. Click **Install**.

Step 5 The InstallShield Wizard Completed window appears. Click **Finish**.

Step 6 Connect the USB cable to the PC and the switch console port. The USB console port LED turns green, and the Found New Hardware Wizard appears. Follow the instructions to complete the driver installation.

Installing the Cisco Microsoft Windows 2000 USB Driver

Procedure

- Step 1** Obtain the Cisco USB console driver file from the Cisco.com web site and unzip it.
- Note** You can download the driver file from the Cisco.com site for downloading the switch software.
- Step 2** Double-click the setup.exe file.
- Step 3** The Cisco Virtual Com InstallShield Wizard begins. Click **Next**.
- Step 4** The Ready to Install the Program window appears. Click **Install**.
- Step 5** The InstallShield Wizard Completed window appears. Click **Finish**.
- Step 6** Connect the USB cable to the PC and the switch console port. The USB console port LED turns green, and the Found New Hardware Wizard appears. Follow the instructions to complete the driver installation.
-

Installing the Cisco Microsoft Windows Vista and Windows 7 USB Driver

Procedure

- Step 1** Obtain the Cisco USB console driver file from the Cisco.com web site and unzip it.
- Note** You can download the driver file from the Cisco.com site for downloading the switch software.
- Step 2** If using 32-bit Windows Vista or Windows 7, double-click the setup.exe file in the Windows_32 folder. If using 64-bit Windows Vista or Windows 7, double-click the setup(x64).exe file in the Windows_64 folder.
- Step 3** The Cisco Virtual Com InstallShield Wizard begins. Click **Next**.
- Step 4** The Ready to Install the Program window appears. Click **Install**.
- Note** If a User Account Control warning appears, click **Allow - I trust this program** to proceed.
- Step 5** The InstallShield Wizard Completed window appears. Click **Finish**.
- Step 6** Connect the USB cable to the PC and the switch console port. The USB console port LED turns green, and the Found New Hardware Wizard appears. Follow the instructions to complete the driver installation.
-

Uninstalling the Cisco Microsoft Windows USB Driver

Uninstalling the Cisco Microsoft Windows XP and 2000 USB Driver

Use the Windows Add or Remove Programs utility or the setup.exe file.

Using the Setup.exe Program

Before You Begin

Disconnect the switch console terminal before uninstalling the driver.

Procedure

- Step 1** Run setup.exe for Windows 32-bit or setup(x64).exe for Windows-64bit. Click **Next**.
 - Step 2** The InstallShield Wizard for Cisco Virtual Com appears. Click **Next**.
 - Step 3** When the Program Maintenance window appears, select the Remove radio button. Click **Next**.
 - Step 4** When the Remove the Program window appears, click **Remove**.
 - Step 5** When the InstallShield Wizard Completed window appears, click **Finish**.
-

Using the Add or Remove Programs Utility

Before You Begin

Disconnect the switch console terminal before uninstalling the driver.

Procedure

- Step 1** Click **Start > Control Panel > Add or Remove Programs**.
 - Step 2** Scroll to Cisco Virtual Com and click **Remove**.
 - Step 3** When the Program Maintenance window appears, select the **Remove** radio button. Click **Next**.
-

Uninstalling the Cisco Microsoft Windows Vista and Windows 7 USB Driver

Before You Begin

Disconnect the switch console terminal before uninstalling the driver.

Procedure

- Step 1** Run setup.exe for Windows 32-bit or setup(x64).exe for Windows-64bit. Click **Next**.
 - Step 2** The InstallShield Wizard for Cisco Virtual Com appears. Click **Next**.
 - Step 3** When the Program Maintenance window appears, select the Remove radio button. Click **Next**.
 - Step 4** When the Remove the Program window appears, click **Remove**.
- Note** If a User Account Control warning appears, click **Allow - I trust this program to proceed**.

Step 5 When the InstallShield Wizard Completed window appears, click **Finish**.

Entering the Initial Configuration Information

To set up the switch, you need to complete the setup program, which runs automatically after the switch is powered on. You must assign an IP address and other configuration information necessary for the switch to communicate with the local routers and the Internet. This information is also needed to use Device Manager or Cisco Network Assistant to configure and manage the switch.

IP Settings

Obtain this information from your network administrator before you start the setup program:

- Switch IP address
- Subnet mask (IP netmask)
- Default gateway (router)
- Enable secret password
- Enable password
- Telnet password

Completing the Setup Program

If your switches are stacked and there are multiple console connections to individual switches in the stack, the initial setup dialog box appears at the console where you first press **Enter**.

Procedure

Step 1 Enter **Yes** at these two prompts:

```
Would you like to enter the initial configuration dialog? [yes/no]: yes
```

```
At any point you may enter a question mark '?' for help.  
Use ctrl-c to abort configuration dialog at any prompt.  
Default settings are in square brackets '['].
```

```
Basic management setup configures only enough connectivity  
for management of the system, extended setup will ask you  
to configure each interface on the system.
```

```
Would you like to enter basic management setup? [yes/no]: yes
```

Step 2 Enter a host name for the switch, and press **Return**.

On a command switch, the host name is limited to 28 characters; on a member switch the name is limited to 31 characters. Do not use *-n*, where *n* is a number, as the last character in a host name for any switch.

```
Enter host name [Switch]: host_name
```

Step 3 Enter an enable secret password, and press **Return**.

The password can be from 1 to 25 alphanumeric characters, can start with a number, is case sensitive, allows spaces, but ignores leading spaces. The secret password is encrypted, and the enable password is in plain text.

```
Enter enable secret: secret_password
```

Step 4 Enter an enable password, and press **Return**.

```
Enter enable password: enable_password
```

Step 5 Enter a virtual terminal (Telnet) password, and press **Return**.

The password can be from 1 to 25 alphanumeric characters, is case sensitive, allows spaces, but ignores leading spaces.

```
Enter virtual terminal password: terminal-password
```

Step 6 To configure the country code, enter **yes** and press **Return**.

```
Do you want to configure country code? [no]: yes
```

Step 7 Enter the country code, and press **Return**.

```
Enter the country code[US]: us
```

Step 8 (Optional) Configure Simple Network Management Protocol (SNMP) by responding to the prompts. You can also configure SNMP later through the CLI, Device Manager, or the Network Assistant application. To configure SNMP later, enter **no**.

```
Configure SNMP Network Management? [no]: no
```

Step 9 Enter the interface name (physical interface or VLAN name) of the connection to the management network, and press **Return**. For this release, always use **vlan1** as that interface.

```
Enter interface name used to connect to the
management network from the above interface summary: vlan1
```

Step 10 Configure the interface by entering the switch IP address and subnet mask and pressing **Return**. The IP address and subnet masks shown are examples.

```
Configuring interface vlan1:
Configure IP on this interface? [yes]: yes
IP address for this interface: 10.4.120.106
Subnet mask for this interface [255.0.0.0]: 255.0.0.0
```

Step 11 Enter **Y** to configure the switch as the cluster command switch. Enter **N** to configure it as a member switch or as a standalone switch.

If you enter **N**, the switch appears as a candidate switch in the Network Assistant GUI. You can configure the switch as a command switch later through the CLI, Device Manager, or the Network Assistant application. To configure it later, enter **no**.

```
Would you like to enable as a cluster command switch? [yes/no]: no
```

You have now completed the initial configuration of the switch. This is an example of the configuration output that appears:

The following configuration command script was created:

```
hostname switch1
enable secret 5 $1$U1q8$D1A/OiaEb190WcBPd9cOn1
enable password enable_password
line vty 0 15
password terminal-password
no snmp-server
!
no ip routing

!
interface Vlan1
no shutdown
ip address 10.4.120.106 255.0.0.0
!
interface GigabitEthernet1/0/1
!
interface GigabitEthernet1/0/2

interface GigabitEthernet1/0/3
!
...<output abbreviated>
!

interface GigabitEthernet1/0/23
!
end
```

Step 12 From these choices that appear, make your selection and press **Return**.

```
[0] Go to the IOS command prompt without saving this config.
```

```
[1] Return back to the setup without saving this config.
```

```
[2] Save this configuration to nvram and exit.
```

Choose (2) to save the configuration to NVRAM to use it the next time the switch reboots.

```
Enter your selection [2]:2
```

The switch now runs this default configuration. If you want to change this configuration or perform other management tasks, see [Management Options](#), on page 20.
