



Cisco IE 3000 Switch Hardware Installation Guide

First Published: March 2013

Last Updated: December 23, 2014

Cisco Systems, Inc.

www.cisco.com

Cisco has more than 200 offices worldwide. Addresses, phone numbers, and fax numbers are listed on the Cisco website at www.cisco.com/go/offices.

THE SPECIFICATIONS AND INFORMATION REGARDING THE PRODUCTS IN THIS MANUAL ARE SUBJECT TO CHANGE WITHOUT NOTICE. ALL STATEMENTS, INFORMATION, AND RECOMMENDATIONS IN THIS MANUAL ARE BELIEVED TO BE ACCURATE BUT ARE PRESENTED WITHOUT WARRANTY OF ANY KIND, EXPRESS OR IMPLIED. USERS MUST TAKE FULL RESPONSIBILITY FOR THEIR APPLICATION OF ANY PRODUCTS.

THE SOFTWARE LICENSE AND LIMITED WARRANTY FOR THE ACCOMPANYING PRODUCT ARE SET FORTH IN THE INFORMATION PACKET THAT SHIPPED WITH THE PRODUCT AND ARE INCORPORATED HEREIN BY THIS REFERENCE. IF YOU ARE UNABLE TO LOCATE THE SOFTWARE LICENSE OR LIMITED WARRANTY, CONTACT YOUR CISCO REPRESENTATIVE FOR A COPY.

The following information is for FCC compliance of Class A devices: This equipment has been tested and found to comply with the limits for a Class A digital device, pursuant to part 15 of the FCC rules. These limits are designed to provide reasonable protection against harmful interference when the equipment is operated in a commercial environment. This equipment generates, uses, and can radiate radio-frequency energy and, if not installed and used in accordance with the instruction manual, may cause harmful interference to radio communications. Operation of this equipment in a residential area is likely to cause harmful interference, in which case users will be required to correct the interference at their own expense.

The following information is for FCC compliance of Class B devices: The equipment described in this manual generates and may radiate radio-frequency energy. If it is not installed in accordance with Cisco's installation instructions, it may cause interference with radio and television reception. This equipment has been tested and found to comply with the limits for a Class B digital device in accordance with the specifications in part 15 of the FCC rules. These specifications are designed to provide reasonable protection against such interference in a residential installation. However, there is no guarantee that interference will not occur in a particular installation.

Modifying the equipment without Cisco's written authorization may result in the equipment no longer complying with FCC requirements for Class A or Class B digital devices. In that event, your right to use the equipment may be limited by FCC regulations, and you may be required to correct any interference to radio or television communications at your own expense.

You can determine whether your equipment is causing interference by turning it off. If the interference stops, it was probably caused by the Cisco equipment or one of its peripheral devices. If the equipment causes interference to radio or television reception, try to correct the interference by using one or more of the following measures:

- Turn the television or radio antenna until the interference stops.
- Move the equipment to one side or the other of the television or radio.
- Move the equipment farther away from the television or radio.
- Plug the equipment into an outlet that is on a different circuit from the television or radio. (That is, make certain the equipment and the television or radio are on circuits controlled by different circuit breakers or fuses.)

Modifications to this product not authorized by Cisco Systems, Inc. could void the FCC approval and negate your authority to operate the product.

The Cisco implementation of TCP header compression is an adaptation of a program developed by the University of California, Berkeley (UCB) as part of UCB's public domain version of the UNIX operating system. All rights reserved. Copyright © 1981, Regents of the University of California.

NOTWITHSTANDING ANY OTHER WARRANTY HEREIN, ALL DOCUMENT FILES AND SOFTWARE OF THESE SUPPLIERS ARE PROVIDED "AS IS" WITH ALL FAULTS. CISCO AND THE ABOVE-NAMED SUPPLIERS DISCLAIM ALL WARRANTIES, EXPRESSED OR IMPLIED, INCLUDING, WITHOUT LIMITATION, THOSE OF MERCHANTABILITY, FITNESS FOR A PARTICULAR PURPOSE AND NONINFRINGEMENT OR ARISING FROM A COURSE OF DEALING, USAGE, OR TRADE PRACTICE.

IN NO EVENT SHALL CISCO OR ITS SUPPLIERS BE LIABLE FOR ANY INDIRECT, SPECIAL, CONSEQUENTIAL, OR INCIDENTAL DAMAGES, INCLUDING, WITHOUT LIMITATION, LOST PROFITS OR LOSS OR DAMAGE TO DATA ARISING OUT OF THE USE OR INABILITY TO USE THIS MANUAL, EVEN IF CISCO OR ITS SUPPLIERS HAVE BEEN ADVISED OF THE POSSIBILITY OF SUCH DAMAGES.

Cisco and the Cisco logo are trademarks or registered trademarks of Cisco and/or its affiliates in the U.S. and other countries. To view a list of Cisco trademarks, go to this URL: www.cisco.com/go/trademarks. Third-party trademarks mentioned are the property of their respective owners. The use of the word partner does not imply a partnership relationship between Cisco and any other company. (1110R)

No combinations are authorized or intended under this document.

Any Internet Protocol (IP) addresses used in this document are not intended to be actual addresses. Any examples, command display output, and figures included in the document are shown for illustrative purposes only. Any use of actual IP addresses in illustrative content is unintentional and coincidental.



| | |
|---|------------|
| Preface | vii |
| Audience | vii |
| Purpose | vii |
| Conventions | vii |
| Related Publications | viii |
| Obtaining Documentation, Obtaining Support, and Security Guidelines | viii |

CHAPTER 1

| | |
|--|------------|
| Overview | 1-1 |
| Overview | 1-1 |
| Switch Models | 1-2 |
| Front-Panel Description | 1-2 |
| 10/100 Ports | 1-8 |
| Dual-Purpose Ports | 1-8 |
| SFP Modules | 1-8 |
| 100BASE-FX Ports | 1-10 |
| 100BASE-X Ports | 1-10 |
| PoE Ports | 1-10 |
| Power and Relay Connector | 1-10 |
| Console Port | 1-11 |
| LEDs | 1-11 |
| Setup LED | 1-14 |
| System LED | 1-14 |
| Alarm LED | 1-14 |
| Power Status LED | 1-15 |
| 10/100 Port Status LEDs | 1-15 |
| 100Base-FX Port Status LEDs | 1-16 |
| Dual-Purpose Port LEDs | 1-16 |
| 100BASE-X SFP Port LEDs | 1-17 |
| PoE Status LED | 1-17 |
| 10/100BASE-T PoE and Non-PoE Port LEDs | 1-17 |
| Compact Flash Memory Card | 1-18 |
| Rear-Panel Description | 1-19 |
| Power Converter (Optional) | 1-20 |

AC-Input Power Supply (Optional) 1-21
 Management Options 1-22
 Network Configurations 1-23

CHAPTER 2

Switch Installation 2-1

Preparing for Installation 2-1
 Warnings 2-2
 Installation Guidelines 2-3
 Environment and Enclosure Guidelines: 2-3
 Other Guidelines 2-3
 Verifying Package Contents 2-5
 Adding Modules to the Switch 2-5
 Expansion Module Configurations 2-5
 Connecting Modules 2-10
 Installing or Removing the Compact Flash Memory Card 2-12
 Verifying Switch Operation 2-13
 Connecting a PC or a Terminal to the Console Port 2-14
 Connecting the Protective Ground and DC Power 2-15
 Grounding the Switch 2-15
 Wiring the DC Power Source 2-18
 Attach the Power and Relay Connector to the Switch 2-23
 Attaching DC Power to the PoE Expansion Modules 2-23
 Running POST 2-25
 Applying Power to the Switch 2-25
 Verify POST Results 2-25
 Disconnect Power 2-26
 Installing the Switch 2-26
 Installing the Switch on a DIN Rail 2-27
 Installing the Switch on the Wall 2-31
 Installing the Switch in a Rack 2-33
 Removing the Switch from a DIN Rail or a Rack 2-35
 Connecting Power and Alarm Circuits 2-36
 Wiring the Protective Ground and DC Power 2-36
 Wiring the External Alarms 2-37
 Connecting Destination Ports 2-40
 Connecting to 10/100 and 10/100/1000 Ports 2-40
 Installing and Removing SFP Transceivers 2-41
 Installing SFP Transceivers into Module Ports 2-42
 Removing SFP Transceivers from Module Ports 2-43

| | |
|---|------|
| Connecting to SFP Transceivers | 2-44 |
| Connecting to a Dual-Purpose Port | 2-45 |
| Connecting to 100BASE-FX Ports | 2-47 |
| Connecting to a PoE Port | 2-48 |
| Connecting the Switch to the Power Converter | 2-48 |
| Attaching the Power Converter to the Switch | 2-49 |
| Installing the Power Converter on a DIN Rail, Wall, or Rack Adapter | 2-50 |
| Connecting the DC Power Clip | 2-50 |
| Connecting the Power Converter to an AC Power Source | 2-51 |
| Preparing the AC Power Cord | 2-51 |
| Connecting the AC Power Cord to the Power Converter | 2-52 |
| Connecting the Power Converter to a DC Power Source | 2-54 |
| Applying Power to the Power Converter | 2-56 |
| Connecting the Switch to the AC-Input Power Supply | 2-56 |
| Attaching the Power Supply to the Switch | 2-56 |
| Installing the AC-input Power Supply on a DIN Rail, Wall, or Rack Adapter | 2-56 |
| Connecting the DC Power Clip | 2-57 |
| Connecting the AC-Input Power Supply to an AC Power Source | 2-57 |
| Connecting the AC Power Cord to the Power Supply | 2-58 |
| Where to Go Next | 2-58 |

CHAPTER 3**Troubleshooting 3-1**

| | |
|--|-----|
| Diagnosing Problems | 3-1 |
| Verify Switch POST Results | 3-1 |
| Verify Switch LEDs | 3-2 |
| Verify Switch Connections | 3-2 |
| Bad or Damaged Cable | 3-2 |
| Ethernet and Fiber Cables | 3-2 |
| Link Status | 3-3 |
| Transceiver Issues | 3-3 |
| Port and Interface Settings | 3-3 |
| Ping End Device | 3-3 |
| Spanning Tree Loops | 3-4 |
| Verify Switch Performance | 3-4 |
| Speed, Duplex, and Autonegotiation | 3-4 |
| Autonegotiation and NIC | 3-4 |
| Cabling Distance | 3-5 |
| How to Clear the Switch IP Address and Configuration | 3-5 |
| How to Recover Passwords | 3-5 |

Finding the Switch Serial Number 3-6

APPENDIX A

Technical Specifications A-1

APPENDIX B

Installation In a Hazardous Environment B-1

Preparing for Installation B-1

Warnings B-2

North American Hazardous Location Approval B-4

EMC Environmental Conditions for Products Installed in the European Union B-5

Installation Guidelines B-5

Environment and Enclosure Guidelines: B-5

Other Guidelines B-5

Verifying Package Contents B-7

Adding Modules to the Switch B-7

Expansion Module Configurations B-8

Connecting Modules B-12

Installing or Removing the Compact Flash Memory Card B-14

Verifying Switch Operation B-15

Connecting a PC or a Terminal to the Console Port B-16

Connecting the Protective Ground and DC Power B-17

Grounding the Switch B-18

Wiring the DC Power Source B-20

Attach the Power and Relay Connector to the Switch B-25

Attaching DC Power to the PoE Expansion Modules B-26

Running POST B-27

Applying Power to the Switch B-27

Verify POST Results B-28

Disconnect Power B-29

Installing the Switch B-29

Installing the Switch on a DIN Rail B-30

Installing the Switch on a Wall B-34

Installing the Switch in a Rack B-36

Removing the Switch from a DIN Rail or a Rack B-38

Connecting Power and Alarm Circuits B-39

Information about the Sealed Relay Device B-40

Wiring the Protective Ground and DC Power B-40

Wiring the External Alarms B-41

Connecting Destination Ports B-44

Connecting to 10/100 and 10/100/1000 Ports B-44

| | |
|---|-------------|
| Installing and Removing SFP Transceivers | B-45 |
| Installing SFP Transceivers into Module Ports | B-46 |
| Removing SFP Transceivers from Module Ports | B-47 |
| Connecting to SFP Transceivers | B-48 |
| Connecting to a Dual-Purpose Port | B-49 |
| Connecting to 100BASE-FX Ports | B-51 |
| Connecting to a PoE Port | B-52 |
| Connecting the Switch to the Power Converter | B-52 |
| Attaching the Power Converter to the Switch | B-52 |
| Installing the Power Converter on a DIN Rail, Wall, or Rack Adapter | B-55 |
| Connecting the DC Power Clip | B-55 |
| Connecting the Power Converter to an AC Power Source | B-56 |
| Preparing the AC Power Cord | B-56 |
| Connecting the AC Power Cord to the Power Converter | B-57 |
| Connecting the Power Converter to a DC Power Source | B-59 |
| Applying Power to the Power Converter | B-61 |
| Connecting the Switch to the AC-Input Power Supply | B-61 |
| Attaching the Power Supply to the Switch | B-61 |
| Installing the AC-input Power Supply on a DIN Rail, Wall, or Rack Adapter | B-62 |
| Connecting the DC Power Clip | B-62 |
| Connecting the AC-Input Power Supply to an AC Power Source | B-63 |
| Connecting the AC Power Cord to the Power Supply | B-63 |
| Where to Go Next | B-64 |

APPENDIX C**Cable and Connectors C-1**

| | |
|---|-------------|
| Connector Specifications | C-1 |
| 10/100 Ports | C-1 |
| Connecting to 10BASE-T- and 100BASE-TX-Compatible Devices | C-1 |
| Connecting to 1000BASE-T Devices | C-2 |
| 100BASE-FX Ports | C-3 |
| PoE Expansion Module Ports (IEM-3000-4PC and IEM-3000-4PC-4TC Only) | C-3 |
| SFP Transceiver Ports | C-4 |
| Dual-Purpose Ports | C-5 |
| Console Port | C-5 |
| Cable and Adapter Specifications | C-5 |
| SFP Transceiver Cable Specifications | C-5 |
| Two Twisted-Pair Cable Pinouts | C-8 |
| Four Twisted-Pair Cable Pinouts for 1000BASE-T Ports | C-9 |
| Crossover Cable and Adapter Pinouts | C-10 |

Identifying a Crossover Cable C-10
Adapter Pinouts C-10

APPENDIX D

Configuring the Switch with the CLI-Based Setup Program D-1

Accessing the CLI from the Console Port D-1
Entering the Initial Configuration Information D-2
 IP Settings D-2
 Completing the Setup Program D-2



Preface

Audience

This guide is for the networking or computer technician responsible for installing Cisco IE 3000 series switches. We assume that you are familiar with the concepts and terminology of Ethernet and local area networking.

Purpose

This guide documents the hardware features of the Cisco IE 3000 switches. It describes the physical and performance characteristics of each switch, explains how to install a switch, and provides troubleshooting information.

This guide does not describe system messages that you might receive or how to configure your switch. For more information, see the switch getting started guide, the switch software configuration guide, the switch command reference, and the switch system message guide on the Cisco.com Technical Support and Documentation home page. For information about the standard Cisco IOS Release 12.1 or 12.2 commands, see the Cisco IOS documentation set from the Cisco.com home page at Technical Support and Documentation > Documentation. On the Cisco Documentation home page, select Release 12.1 or 12.2 from the Cisco IOS Software drop-down list.

Conventions

This document uses the following conventions and symbols for notes, cautions, and warnings.



Note

Means *reader take note*. Notes contain helpful suggestions or references to materials not contained in this manual.



Caution

Means *reader be careful*. In this situation, you might do something that could result in equipment damage or loss of data.



Warning

This warning symbol means danger. You are in a situation that could cause bodily injury. Before you work on any equipment, be aware of the hazards involved with electrical circuitry and be familiar with standard practices for preventing accidents. Use the statement number provided at the end of each warning to locate its translation in the translated safety warnings that accompanied this device. Statement 1071

The safety warnings for this product are translated into several languages in the *Regulatory Compliance and Safety Information for the Cisco IE 3000 Switch* that ships with the product. The EMC regulatory statements are also included in that guide.

Related Publications

Before installing, configuring, or upgrading the switch, see the release notes on Cisco.com for the latest information.

These documents provide complete information about the switch and are available on Cisco.com:

- *Cisco IE 3000 Switch Getting Started Guide*
- *Regulatory Compliance and Safety Information for the Cisco IE 3000 Switch*
- *Release Notes for the Cisco IE 3000 Switch*
- *Cisco IE 3000 Switch Software Configuration Guide*
- *Cisco IE 3000 Switch Command Reference*
- *Cisco IE 3000 Switch System Message Guide*
- Device manager online help (available on the switch)
- *Cisco Small Form-Factor Pluggable Modules Installation Notes*

These compatibility matrix documents are available from this Cisco.com site:

http://www.cisco.com/en/US/products/hw/modules/ps5455/products_device_support_tables_list.html

- *Cisco Gigabit Ethernet Transceiver Modules Compatibility Matrix* (not orderable but available on Cisco.com)
- *Cisco Small Form-Factor Pluggable Modules Compatibility Matrix* (not orderable but available on Cisco.com)

Obtaining Documentation, Obtaining Support, and Security Guidelines

For information on obtaining documentation, obtaining support, providing documentation feedback, security guidelines, and also recommended aliases and general Cisco documents, see the monthly *What's New in Cisco Product Documentation*, which also lists all new and revised Cisco technical documentation, at:

<http://www.cisco.com/en/US/docs/general/whatsnew/whatsnew.html>



Overview

This chapter describes the Cisco Industrial Ethernet (IE) 3000 switch, hereafter referred to as *the switch*, and covers these topics:

- [Overview, page 1-1](#)
- [Switch Models, page 1-2](#)
- [Front-Panel Description, page 1-2](#)
- [Compact Flash Memory Card, page 1-18](#)
- [Rear-Panel Description, page 1-19](#)
- [Power Converter \(Optional\), page 1-20](#)
- [Management Options, page 1-22](#)
- [Network Configurations, page 1-23](#)

Overview

The Cisco IE 3000 switch provides a rugged and secure switching infrastructure for harsh environments. It is suitable for industrial Ethernet applications, including factory automation, intelligent transportation systems (ITSs), substations, and other deployments in harsh environments.

You can connect these switches to office networking devices like Cisco IP Phones, Cisco Wireless Access Points workstations, and other devices such as servers, routers, and other switches. In industrial environments, you can connect any Ethernet-enabled industrial communication devices, including programmable logic controllers (PLCs), human-machine interfaces (HMIs), drives, sensors, traffic signal controllers, and intelligent electronic devices (IEDs).

You can mount the switch on a DIN rail in an industrial enclosure, on a wall or panel, and with some restrictions, in a standard 19-inch rack. Its components are designed to withstand extremes in temperature, vibration, and shock that are common in an industrial environment.



Note

The switch does not have cooling fans.

Switch Models

Table 1-1 describes the switch and the expansion modules. The Cisco IE-3000-4TC and the Cisco IE-3000-8TC are the switch models, and the Cisco IEM-3000-8TM and the Cisco IEM-3000-8FM are expansion modules that you can connect to increase the number of ports. For instructions on how to connect the expansion modules to the switch, see the “Adding Modules to the Switch” section on page 2-5.

Table 1-1 Cisco IE 3000 Switch Models and Expansion Modules

| Switch Model | Description |
|---------------------------------|--|
| Cisco IE-3000-4TC | 4 10/100BASE-T Ethernet ports and 2 dual-purpose ports, each with a 10/100/1000BASE-T copper port and an SFP (small form-factor pluggable) module slot |
| Cisco IE-3000-8TC | 8 10/100BASE-T Ethernet ports and 2 dual-purpose ports |
| Cisco IE-3000-4TC-E | 4 10/100BASE-T Ethernet ports and 2 dual-purpose ports (supports the IP services software feature set) |
| Cisco IE-3000-8TC-E | 8 10/100BASE-T Ethernet ports and 2 dual-purpose ports (supports the IP services software feature set) |
| Expansion Modules | |
| Cisco IEM-3000-8TM | Expansion module with 8 10/100BASE-T copper Ethernet ports |
| Cisco IEM-3000-8FM | Expansion module with 8 100BASE-FX fiber-optic Ethernet ports |
| Cisco IEM-3000-4SM | Expansion module with 4 100BASE-X SFP Ethernet ports |
| Cisco IEM-3000-8SM | Expansion module with 8 100BASE-X SFP Ethernet ports |
| Cisco IEM-3000-4PC ¹ | Expansion module with 4 PoE ports |
| Cisco IEM-3000-4PC-4TC | Expansion module with 4 PoE ports and 4 non-PoE FE ports |

1. The IEM-3000-4PC expansion module and the IEM-3000-4PC-4TC expansion module require a separate DC power source. This source can be either the PWR-IE65W-PC-DC DC-input power supply or the PWR-IE65W-PC-AC AC-input power supply or you can use site source DC power.

Front-Panel Description

This section describes the front panel and includes these sections:

- [10/100 Ports, page 1-8](#)
- [Dual-Purpose Ports, page 1-8](#)
- [100BASE-FX Ports, page 1-10](#)
- [Power and Relay Connector, page 1-10](#)
- [Console Port, page 1-11](#)
- [LEDs, page 1-11](#)

The switch front panel contains the ports, the LEDs, and the power and relay connectors. [Figure 1-1](#) to [Figure 1-6](#) show the switch and expansion module front panels.

Figure 1-1 Cisco IE-3000-8TC Switch

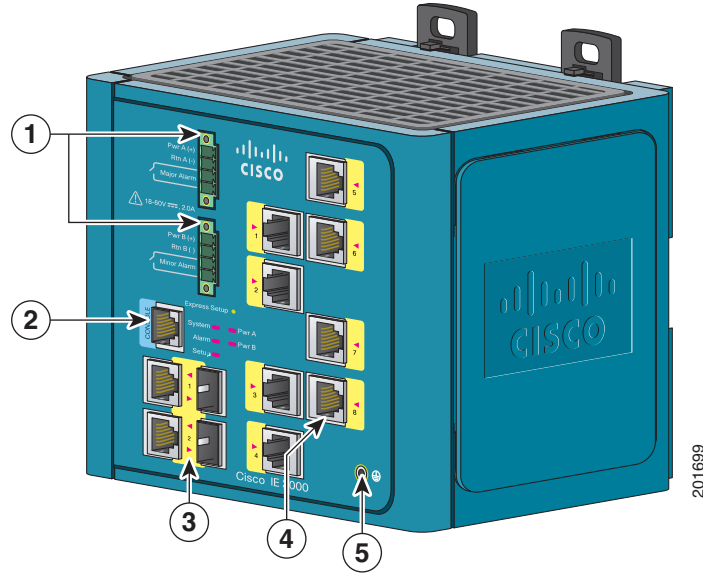

| | | | |
|----------|----------------------------|----------|------------------------------|
| 1 | Power and relay connectors | 4 | 10/100 ports |
| 2 | Console port | 5 | Protective ground connection |
| 3 | Dual-purpose ports | | |

Figure 1-2 Cisco IE-3000-4TC Switch

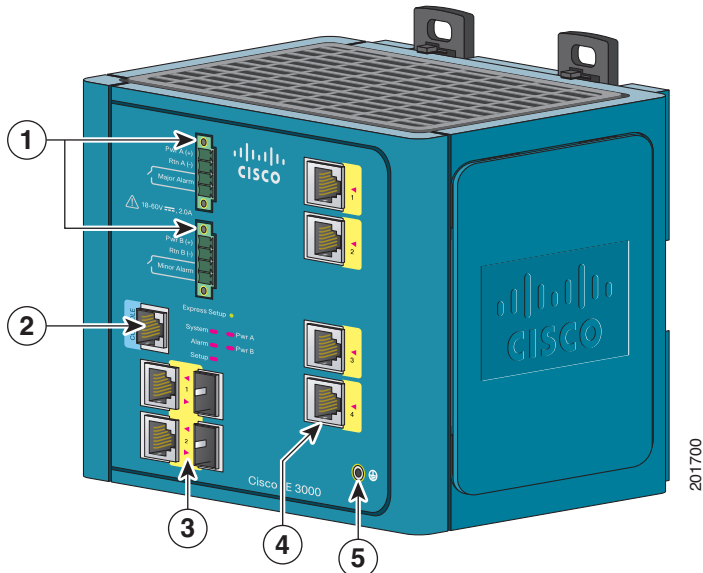

| | | | |
|----------|----------------------------|----------|------------------------------|
| 1 | Power and relay connectors | 4 | 10/100 ports |
| 2 | Console port | 5 | Protective ground connection |
| 3 | Dual-purpose ports | | |

Figure 1-3 Cisco IEM-3000-8TM Expansion Module

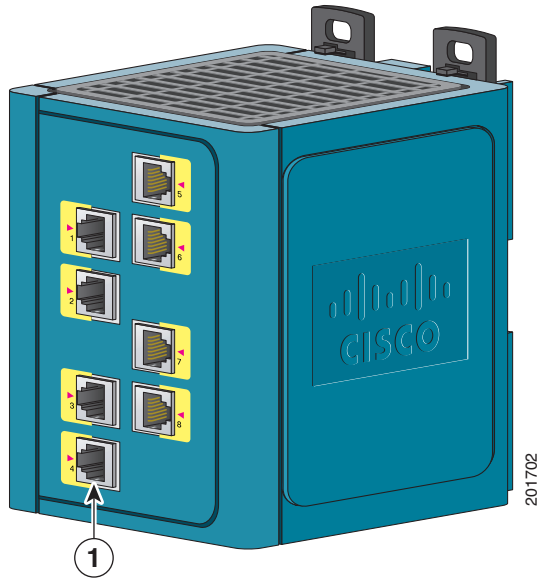

| | |
|----------|--------------|
| 1 | 10/100 ports |
|----------|--------------|

Figure 1-4 Cisco IEM-3000-8FM Expansion Module

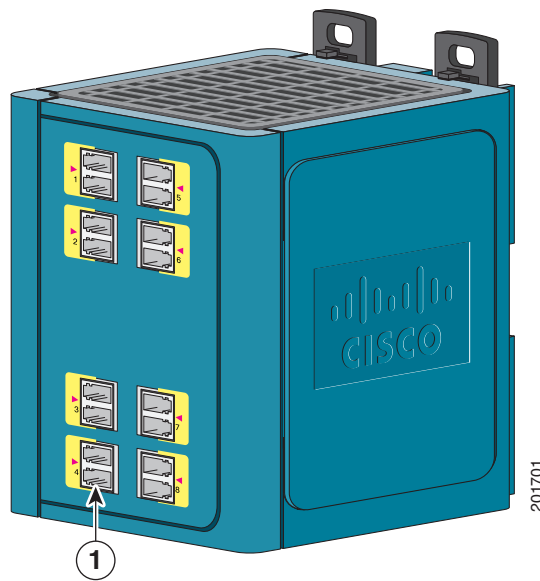

| | |
|----------|------------------|
| 1 | 100BASE-FX ports |
|----------|------------------|

Figure 1-5 Cisco IEM-3000-4SM Expansion Module

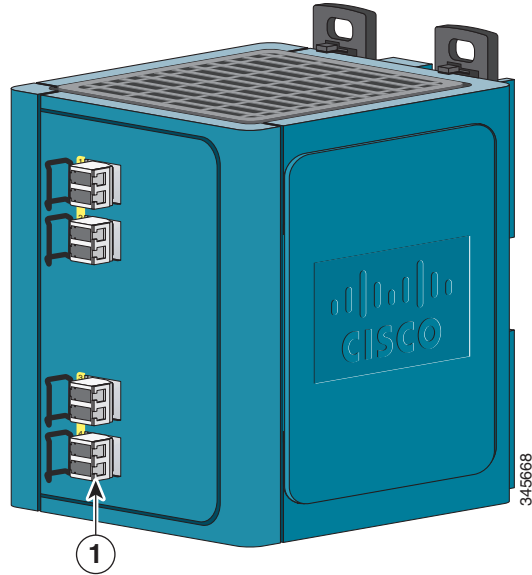

| | | |
|---|---------------------|--|
| 1 | 100BASE-X SFP ports | |
|---|---------------------|--|

Figure 1-6 Cisco IEM-3000-8SM Expansion Module

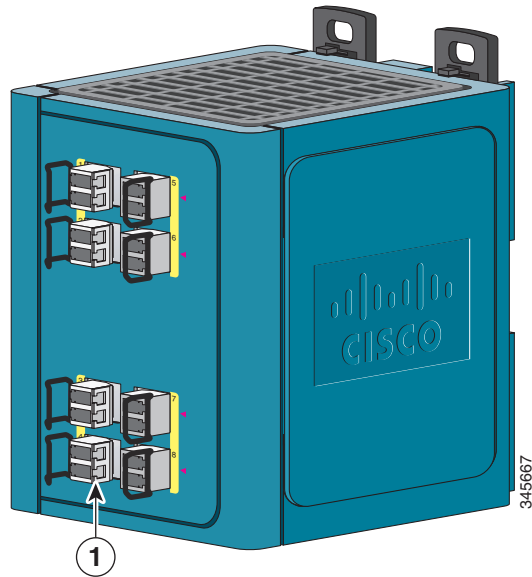

| | | |
|---|---------------------|--|
| 1 | 100BASE-X SFP ports | |
|---|---------------------|--|

Figure 1-7 Cisco IEM-3000-4PC PoE Expansion Module

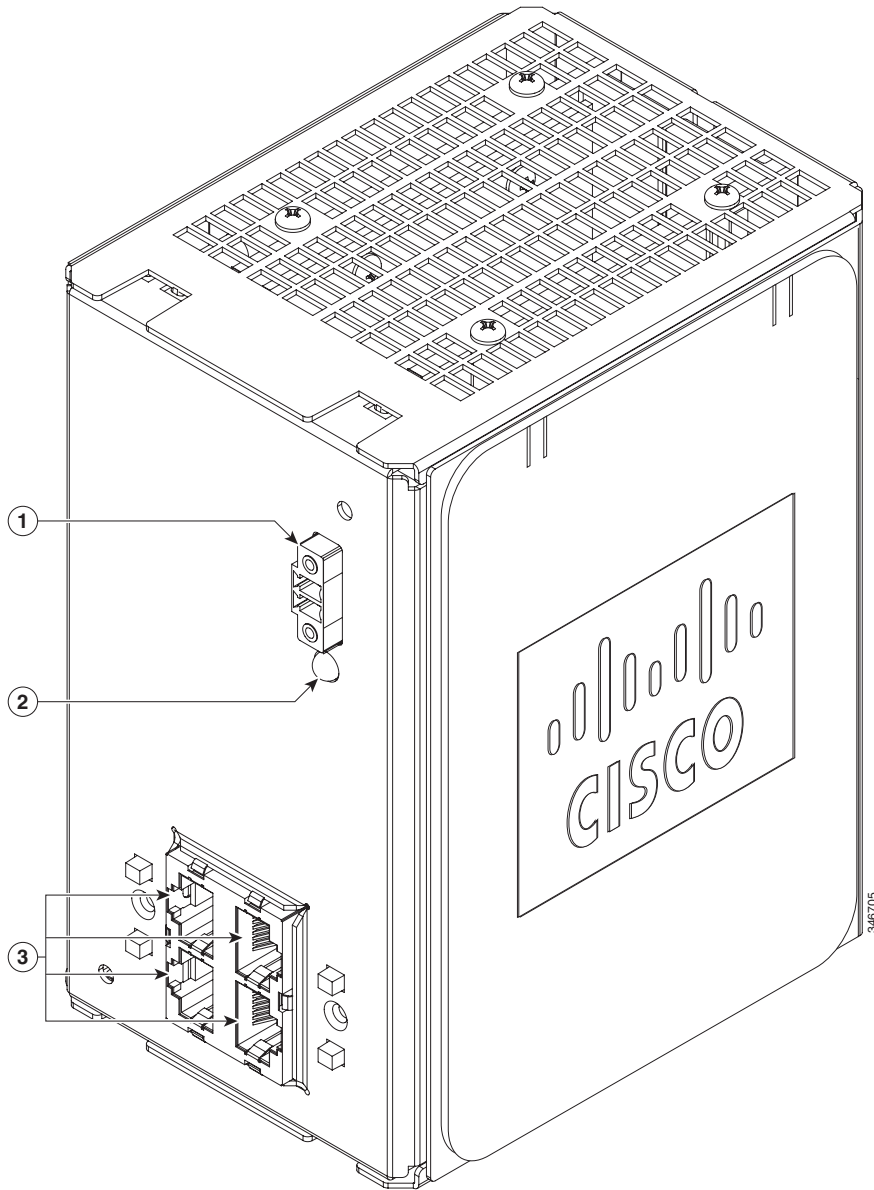

| | | | |
|---|-------------------------|---|-----------|
| 1 | DC Input terminal block | 3 | PoE ports |
| 2 | POE STATUS LED | | |

Figure 1-8 Cisco IEM-3000-4PC-4TC PoE Expansion Module

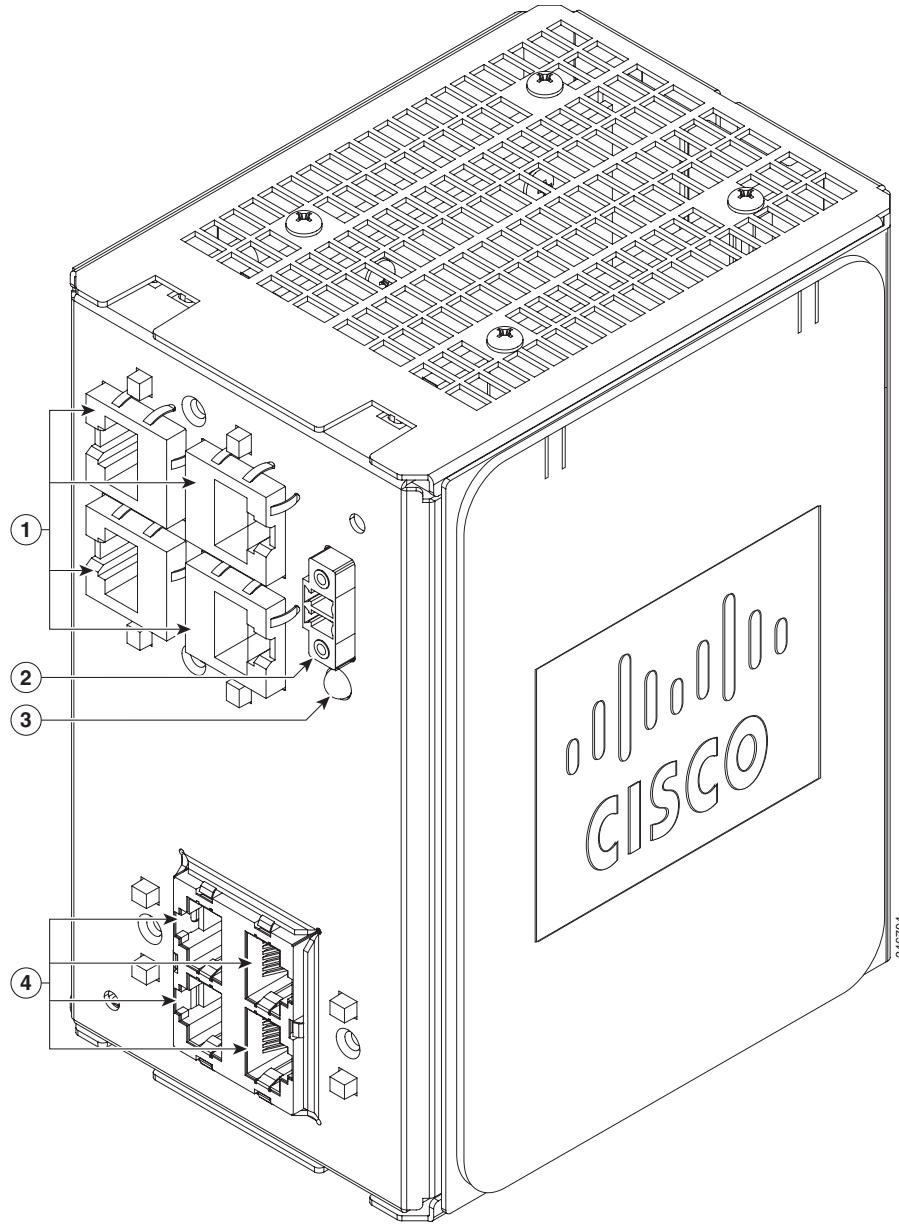

| | | | |
|----------|-------------------------|----------|----------------|
| 1 | 10/100 Non-PoE ports | 3 | POE STATUS LED |
| 2 | DC-Input terminal block | 4 | PoE ports |

10/100 Ports

You can set the 10/100 ports to operate at 10 or 100 Mb/s in full-duplex or half-duplex mode. You can also set these ports for speed and duplex autonegotiation in compliance with IEEE 802.3AB. (The default setting is autonegotiate.) When set for autonegotiation, the port senses the speed and duplex settings of the attached device and advertises its own capabilities. If the connected device also supports autonegotiation, the switch port negotiates the best connection (that is, the fastest line speed that both devices support and full-duplex transmission if the attached device supports it) and configures itself accordingly. In all cases, the attached device must be within 328 feet (100 meters). 100BASE-TX traffic requires Category 5 cable. 10BASE-T traffic can use Category 3 or Category 4 cables.

When connecting the switch to workstations, servers, routers, and Cisco IP Phones, be sure that the cable is a straight-through cable.

For copper ports, you can use the **mdix auto** interface configuration command in the command-line interface (CLI) to enable the automatic medium-dependent interface crossover (auto-MDIX) feature. When the auto-MDIX feature is enabled, the switch detects the required cable type for copper Ethernet connections and configures the interfaces accordingly. For configuration information for this feature, see the switch software configuration guide or the switch command reference.

Dual-Purpose Ports

A dual-purpose port can be configured as either a 10/100/1000 port or as an SFP module port. Only one port can be active at a time. If both ports are connected, the SFP module port has priority.

You can set the 10/100/1000 ports to operate at 10, 100, or 1000 Mb/s in full-duplex or half-duplex mode. You can configure them as fixed 10, 100, or 1000 Mb/s (Gigabit) Ethernet ports and can configure the duplex setting. (See the switch software configuration for more information.)

You can use Gigabit Ethernet SFP modules to establish fiber-optic connections to other switches. These transceiver modules are field-replaceable, providing the uplink interfaces when inserted in an SFP module slot. You use fiber-optic cables with LC connectors to connect to a fiber-optic SFP module.

For more information about these SFP modules, see the “[SFP Modules](#)” section on page 1-8, your SFP module documentation or the release note for your switch software.

SFP Modules

The switch Ethernet SFP modules provide connections to other devices. These field-replaceable transceiver modules provide the uplink interfaces. The modules have LC connectors for fiber-optic connections or RJ-45 connectors for copper connections. You can use any combination of the supported SFP modules listed in [Table 1-2](#).

Table 1-2 Maximum Operating Temperature

| Type of SFP Module | Model |
|--|--|
| Rugged and Industrial SFPs –40 to 140°F (–40 to 60°C) | <ul style="list-style-type: none"> • GLC-SX-MM-RGD • GLC-LX-SM-RGD • GLC-FE-100LX-RGD • GLC-FE-100FX-RGD • GLC-ZX-SM-RGD • GLC-BX40-D-I with digital optical monitoring (DOM) support • GLC-BX40-DA-I with DOM support • GLC-BX80-D-I with DOM support • GLC-BX40-U-I with DOM support • GLC-BX80-U-I with DOM support |
| Commercial SFPs 32 to 113°F (0 to 45°C) | <ul style="list-style-type: none"> • GLC-BX-D with DOM support • GLC-BX-U with DOM support • GLC-FE-100LX • GLC-FE-100BX-D • GLC-FE-100BX-U • GLC-FE-100FX • GLC-FE-100EX • GLC-FE-100ZX • CWDM SFP with DOM support • DWDM SFP with DOM support • GLC-T |
| Extended temperature SFPs 23 to 140°F (–5 to 60°C) | <ul style="list-style-type: none"> • SFP-GE-L with DOM support • SFP-GE-S with DOM support • SFP-GE-Z with DOM support • GLC-SX-MMD with DOM support • GLC-EX-SMD with DOM support • GLC-LH-MMD with DOM support • GLC-ZX-SMD with DOM support |

For the most up-to-date list of supported SFP models for Cisco Industrial Ethernet switches, see http://www.cisco.com/en/US/docs/interfaces_modules/transceiver_modules/compatibility/matrix/OL_6981.html#wp138176

For information about SFP modules, see your SFP module documentation and the “Installing and Removing SFP Transceivers” section on page 2-41. For cable specifications, see Appendix C, “Cable and Connectors.”

100BASE-FX Ports

The IEEE 802.3u 100BASE-FX ports provide full-duplex 100 Mb/s connectivity over multimode fiber (MMF) cables. These ports use a small-form-factor fixed (SFF) fiber-optic transceiver module that accepts a dual LC connector. The cable can be up to 1.24 miles (2 km) in length.

100BASE-X Ports

The IEEE 802.3u 100BASE-X ports provide full-duplex 100 Mb/s connectivity over both single-mode (SMF) and multimode fiber (MMF) cables. These ports use a small-form-factor pluggable (SFP) fiber-optic transceiver module that accepts a dual LC connector (except in the case of the GLC-FE-100BX-U and GLC-FE-100BX-D SFP transceivers). With the GLC-FE-100ZX SFP transceiver installed, cable runs of up to 49.6 miles (80 km) are supported.

PoE Ports

The IEM-3000-4PC and the IEM-3000-4PC-4TC expansion modules provide 10/100BASE-T PoE capability to the IE3000 base switch. Both expansion modules support up to 4 PoE (802.3af) or 4 PoE+ (802.3at) devices. The PoE expansion modules require a dedicated power supply for PoE power.

Power and Relay Connector

You connect the DC power and alarm signals to the switch through two front panel connectors. One connector provides primary DC power (supply A) and the major alarm signal, and a second connector (supply B) provides secondary power and the minor alarm signal. The two connectors are physically identical and are in the upper left side of the front panel. See [Figure 1-2](#).

The switch accessory pack includes the mating power and relay connectors. These connectors provide screw terminals for terminating the DC power and alarm wire and the connector plugs into the power and relay receptacles on the front panel. The positive DC power connection is labeled *V*, and the return connection is labeled *RT* (see [Figure 1-9](#)).

Figure 1-9 Power and Relay Connector

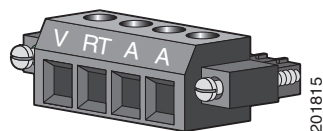

The switch can operate with a single power source or with dual power sources. When both power sources are operational, the switch draws power from the DC source with the higher voltage. If one of the two power sources fail, the other continues to power the switch.

The power and relay connectors also provide an interface for two independent alarm relays: the major and the minor alarms. The relays can be activated for environmental, power supply, and port status alarm conditions and can be configured to indicate an alarm with either open or closed contacts. The relay itself is normally open, so under power failure conditions, the contacts are open. From the CLI, you can associate any alarm condition with one or with both alarm relays.

Alarm relays often control an external alarm device, such as a bell or a light. To connect an external alarm device to the relay, you must connect two relay contact wires to complete an electrical circuit. Both alarm terminals on the power and relay connector are labeled A, and you can connect them without regard to polarity.

See the switch software configuration guide for instructions on configuring the alarm relays.

For more information about the power and relay connector, see [Appendix C, “Cable and Connectors.”](#)

You can get replacement power and relay connectors (PWR-IE3000-CNCT=) by calling Cisco Technical Support.

Console Port

You can connect a switch to a PC through the console port and the supplied RJ-45-to-DB-9 adapter cable. If you want to connect a switch to a terminal, you need to provide an RJ-45-to-DB-25 female DTE adapter. You can order a kit (part number ACS-DSBUASYN=) with that adapter from Cisco Systems. For console-port and adapter-pinout information, see the [“Two Twisted-Pair Cable Pinouts”](#) section on [page C-8](#).

LEDs

You can use the LEDs to monitor the switch status, activity, and performance. [Figure 1-10](#) to [Figure 1-13](#) show the front panel LEDs, and the following sections describe them.

All LEDs are visible through the GUI management applications—the Cisco Network Assistant application for multiple switches and the device manager GUI for a single switch. The switch software configuration guide describes how to use the CLI to configure and to monitor individual switches and switch clusters.

Figure 1-10 LEDs on the Cisco IE 3000 Switch

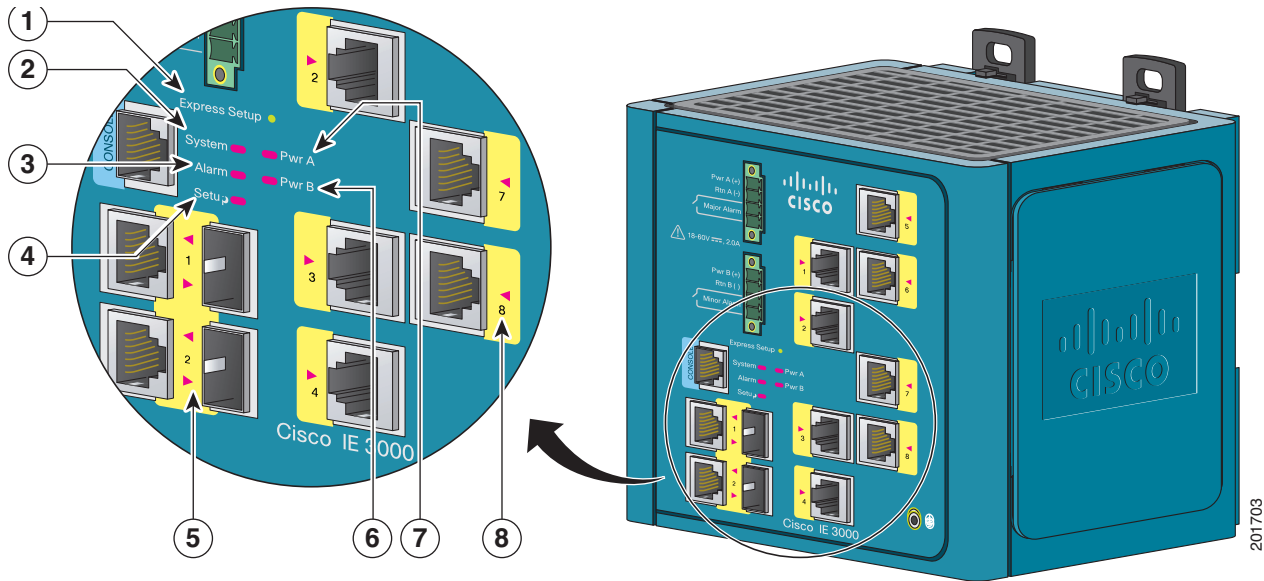

| | | | |
|---|----------------------|---|------------------------------|
| 1 | Express setup button | 5 | Dual-purpose uplink port LED |
| 2 | System LED | 6 | Pwr B LED |
| 3 | Alarm LED | 7 | Pwr A LED |
| 4 | Setup LED | 8 | Port LED |

Figure 1-11 LEDs on the Cisco IEM-3000-8TM Module

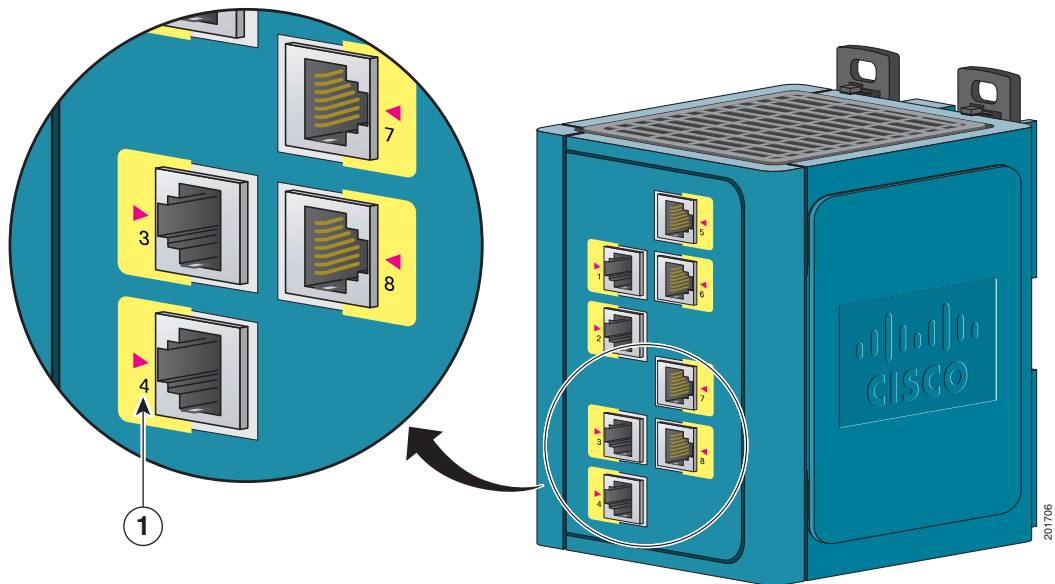

| | |
|---|-----------------|
| 1 | 10/100 port LED |
|---|-----------------|

Figure 1-12 LEDs on the Cisco IEM-3000-8FM Module

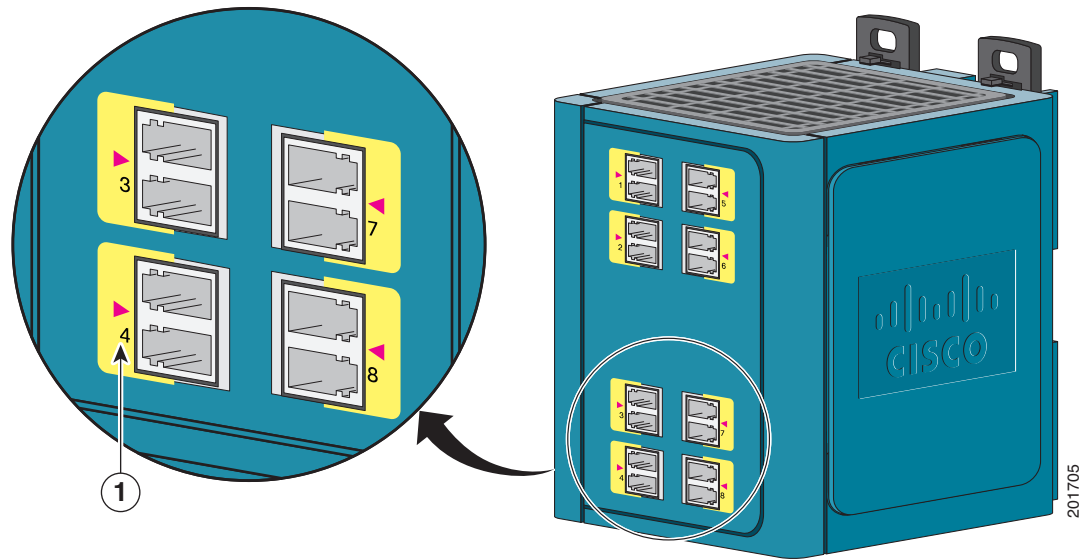

| | |
|----------|-----------------------|
| 1 | 100BASE -FX port LEDs |
|----------|-----------------------|

Figure 1-13 LEDs on the Cisco IEM-3000-8SM Module

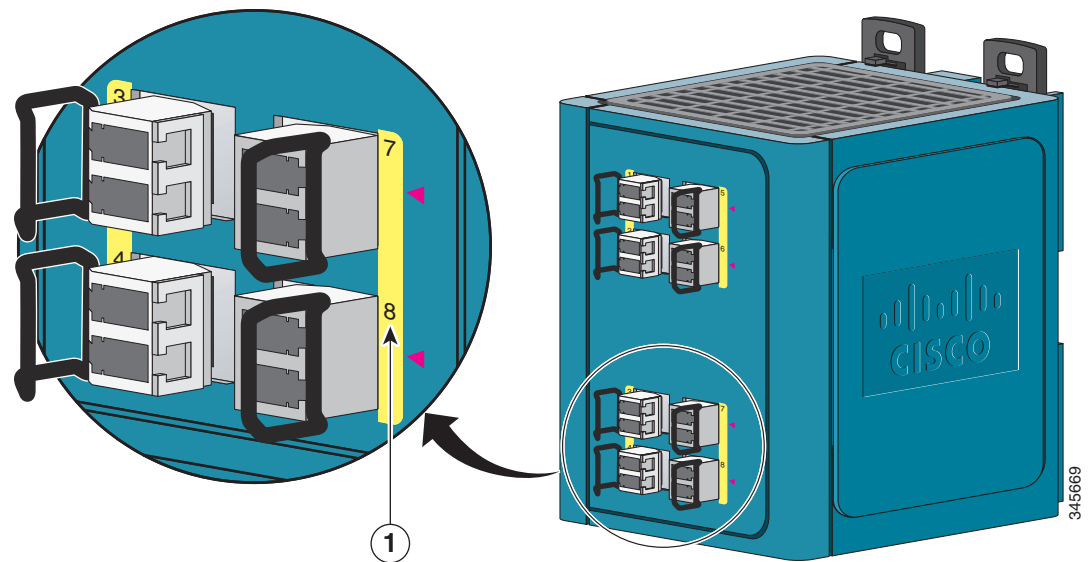

| | |
|----------|---------------------|
| 1 | 100BASE-X port LEDs |
|----------|---------------------|

Note

The port numbering sequence is the same for the IEM-3000-4SM expansion module.

The LED arrangement on the IEM-3000-4PC PoE expansion module is similar to the LED arrangement on the IEM-3000-4PC-4TC PoE expansion module except that the IEM-3000-4PC module does not have the four additional non-PoE ports with their associated port LEDs.

Setup LED

The Setup LED displays the express setup mode for the initial configuration. [Table 1-3](#) lists the LED colors and their meanings.

Table 1-3 Setup LED

| Color | Setup Status |
|----------------|---|
| Off (dark) | Switch is configured as a managed switch. |
| Solid green | Switch is in initial setup. |
| Blinking green | Switch is in initial setup, in recovery, or initial setup is incomplete. |
| Solid red | Switch failed to start initial setup or recovery because there is no available switch port to which to connect the management station. Disconnect a device from a switch port, and then press the Express Setup button. |

System LED

The System LED shows whether the system is receiving power and is functioning properly. [Table 1-4](#) lists the system LED colors and their meanings.

Table 1-4 System LED

| Color | System Status |
|-------|-------------------------------------|
| Off | System is not powered on. |
| Green | System is operating normally. |
| Red | Switch is not functioning properly. |

Alarm LED

[Table 1-5](#) lists the alarm LED colors and their meanings.

Table 1-5 Alarm Status LED

| Color | System Status |
|--------------|--|
| Off | Alarms are not configured, or the switch is off. |
| Green | Alarms are configured. |
| Blinking red | Switch has detected a major alarm. |
| Red | Switch has detected a minor alarm. |

Power Status LED

The switch can operate with one or two DC power sources. Each DC input has an associated LED that shows the status of the corresponding DC input. If power is present on the circuit, the LED is green. If power is not present, the LED color depends on the alarm configuration. If alarms are configured, the LED is red when power is not present; otherwise, the LED is off.

If the switch has dual power sources, the switch draws power from the power source with the higher voltage. If the one of the DC sources fails, the alternate DC source powers the switch, and the corresponding power status LED is green. The power status for the failed DC source is either off or red, depending on the alarm configuration.

Table 1-6 lists the power status LED colors and meanings.

Table 1-6 Power Status LEDs

| Color | System Status |
|-------|---|
| Off | Power is not present on the circuit, or the system is not powered up. |
| Green | Power is present on the associated circuit. |
| Red | Power is not present on the associated circuit, and the power supply alarm is configured. |



Note

The Pwr A and Pwr B LEDs show that power is not present on the switch if the power input drops below the low valid level. The power status LEDs only show that power is present if the voltage at the switch input exceeds the valid level. The difference, or *hysteresis*, ensures that the power status LEDs do not oscillate at values near 18 V.

For information about the power LED colors during the power-on self-test (POST), see the “[Verifying Switch Operation](#)” section on page 2-13.

10/100 Port Status LEDs

Each 10/100 port has a port status LED, also called a port LED, as shown in [Figure 1-10](#), [Figure 1-11](#), and [Figure 1-12](#). [Table 1-7](#) displays LED information about the switch and the individual ports.

Table 1-7 10/100 Port Status LEDs

| Color | System Status |
|----------------|--|
| Off | No link. |
| Solid green | Link present. |
| Blinking green | Activity. Port is sending or receiving data. |
| Blinking amber | A link blocked by Spanning Tree Protocol (STP) is sending or receiving data. |

Table 1-7 10/100 Port Status LEDs (continued)

| Color | System Status |
|-------------------------|--|
| Alternating green-amber | Link fault. Error frames can affect connectivity, and errors such as excessive collisions, CRC errors, and alignment and jabber errors are monitored for a link-fault indication. |
| Solid amber | Port is not forwarding. Port was disabled by management, an address violation, or STP. Note After a port is reconfigured, the port LED can remain amber for up to 30 seconds while STP checks the switch for possible loops. |

100Base-FX Port Status LEDs

These LEDs display information about the individual ports. See [Table 1-8](#).

Table 1-8 100BASE-FX MM Uplink Port Status LEDs

| Color | System Status |
|-------------------------|--|
| Off | No link. |
| Solid green | Link is present. |
| Blinking green | Activity. Port is sending or receiving data. |
| Blinking amber | A link blocked by Spanning Tree Protocol (STP) is sending or receiving data. |
| Alternating green-amber | Link is faulty. |
| Solid amber | Link is disabled. |

Dual-Purpose Port LEDs

[Figure 1-14](#) shows the LEDs on a dual-purpose port. You can configure each port as either a 10/100/1000 port through the RJ-45 connector or as an SFP module, but not both at the same time. The LEDs show how the port is being used (Ethernet or SFP module).

The LED colors have the same meanings as described in [Table 1-7](#).

Figure 1-14 Dual-Purpose Port LEDs

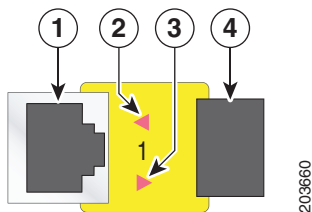

| | | | |
|----------|-----------------------|----------|----------------------------|
| 1 | RJ-45 connector | 3 | SFP module port in-use LED |
| 2 | RJ-45 port in-use LED | 4 | SFP module slot |

100BASE-X SFP Port LEDs

The 100BASE-X SFP port LEDs are located on the two SFP expansion modules. The LED colors have the same meanings as described in [Table 1-7](#).

PoE Status LED

The PoE status LED on the front panel of the IEM-3000-4PC and the IEM-3000-4PC-4TC PoE expansion modules displays the functionality and status of the PoE ports. The LED colors and meanings are listed in [Table 1-9](#).

Table 1-9 PoE Status LED Colors and Meanings

| Color | PoE Status |
|-----------------------------|---|
| Off | PoE is off. If the powered device is receiving power from an AC power source, the port LED is off even if the powered device is connected to the switch port. |
| Green | PoE is on. The port LED is green only when the switch port is providing power. |
| Alternating green and amber | PoE is denied because providing power to the powered device will exceed the power capacity of the expansion module. |
| Flashing amber | PoE is off due to a fault.  Caution Noncompliant cabling or powered devices can cause a PoE port fault. Use only standard-compliant cabling to connect Cisco prestandard IP Phones and wireless access points or IEEE 802.3af-compliant devices. You must remove any cable or device that causes a PoE fault. |
| Amber | PoE for the port is disabled. (PoE is enabled by default.) |

10/100BASE-T PoE and Non-PoE Port LEDs

The 10/100BASE-T PoE and non-PoE port status LEDs on the front panel of the IEM-3000-4PC and the IEM-3000-4PC-4TC PoE expansion modules display the functionality and status of the individual ports on the expansion modules.

Table 1-10 10/100BASE-T Port Status LEDs for the PoE Expansion Modules

| Color | Port Status |
|----------------|--|
| Off | Port is not connected. |
| Flashing amber | Link negotiation in progress on the port. |
| Flashing green | Link is up and there is data transfer in progress on the port. |
| Amber | Link negotiation failure on the port. |
| Green | Link is up but there is no data transfer. |

Compact Flash Memory Card

The switch supports a compact flash memory card that makes it possible to replace a failed switch without reconfiguring the new switch. The slot for the compact flash memory card is on the bottom of the switch. See [Figure 1-15](#).

**Note**

For more information on inserting and removing the compact flash memory card, see the [“Installing or Removing the Compact Flash Memory Card”](#) section on page 2-12.

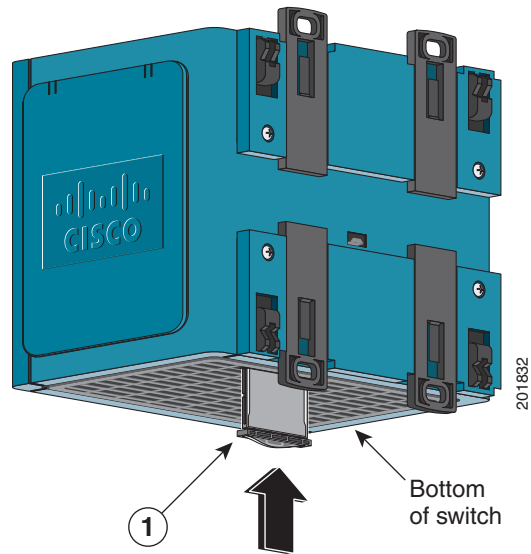
Figure 1-15 Compact Flash Memory Card Slot**Note**

You can obtain replacement flash memory cards (CF-IE3000=) by calling Cisco Technical Support.

Rear-Panel Description

The rear panel of the switch, modules, and power converter have latches for installation on either a DIN rail or a wall. See [Figure 1-16](#). The latches slide outward to position the switch over a DIN rail and slide inward to secure the switch to a DIN rail. The feet stabilize the switch when it is mounted on the wall.

Figure 1-16 Cisco IE 3000 Switch Rear Panel

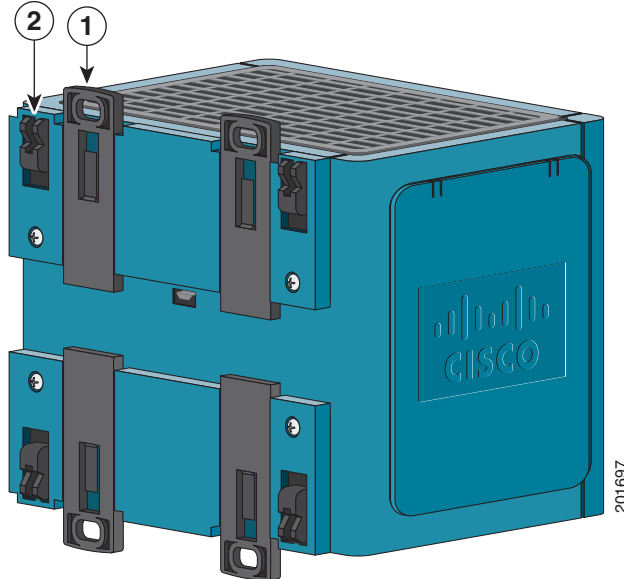

| | | | |
|----------|----------------|----------|---------------------------|
| 1 | DIN rail latch | 2 | Foot in recessed position |
|----------|----------------|----------|---------------------------|

Power Converter (Optional)

The switch can be used with an optional AC/DC power converter. The power converter (PWR-IE3000-AC) can supply 24-VDC power to one switch and up to two modules. The power converter is mounted on the side of a switch and provides power to the switch through a preassembled power cable.



Note

The power converter (PWR-IE3000-AC=) is sold separately.

You can get a replacement power cable (PWR-IE3000-CLP=) by calling Cisco Technical Support.

For installation and connection procedures for the power converter, see the [“Connecting the Switch to the Power Converter”](#) section on page 2-48.

Figure 1-17 displays the power converter.

Figure 1-17 Cisco IE 3000 Switch AC/DC Power Converter

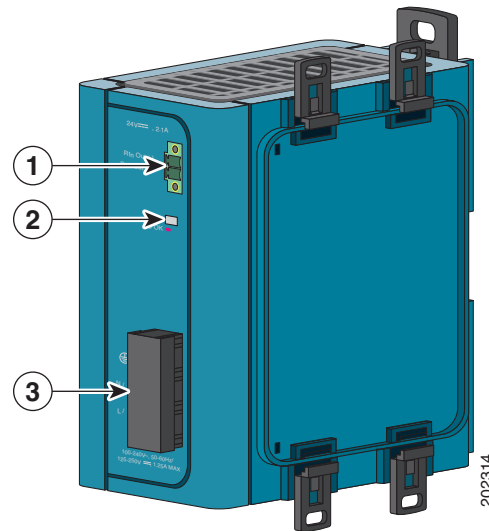

| | | | |
|---|---------------------|---|-----------------------------|
| 1 | DC output connector | 3 | AC/DC input power connector |
| 2 | Status LED | | |

AC-Input Power Supply (Optional)

A 50 W AC-input power supply is available as an option for the IE 3000 switch. The power supply comes in two styles:

- PWR-IE50W-AC—An AC-input power supply with a terminal block connector for the source AC cable.
- PWR-IE50W-AC-IEC— An AC-input power supply with an IEC C14 appliance connector for a detachable AC power cord.

Figure 1-18 shows the AC-input power supply.

The power supply is designed to operate from source AC range of 85 to 264 VAC (115 VAC nominal at 60 Hz or 230 VAC nominal at 50 Hz) and provides 24 VDC to one switch and up to two modules. The power supply attaches to the side of a switch and provides power to the switch through a preassembled power cable (PWR-IE3000-CLP=).

Figure 1-18 AC-Input Power Supply (PWR-IE50W-AC= Shown)

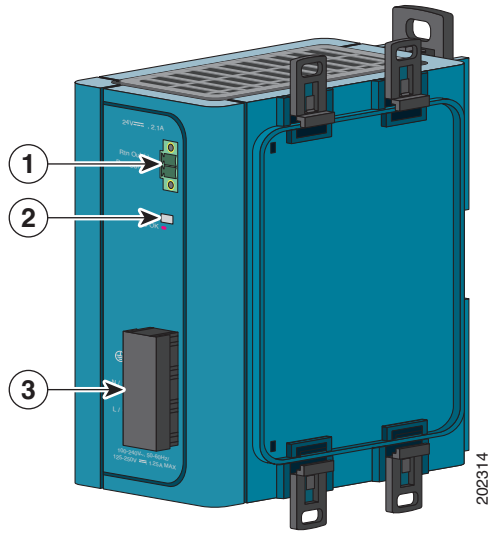

| | | | |
|---|------------------|---|--|
| 1 | DC out connector | 3 | Source AC terminal block (Cover shown installed) |
| 2 | STATUS LED | | <p>Note The source AC terminal block shown in the illustration is replaced by an IEC C14 appliance connector on the PWR-50W-AC-IEC= power supply.</p> |

Management Options

The switch supports these management options:

- Cisco Network Assistant

Cisco Network Assistant is a PC-based network management GUI application optimized for LANs of small and medium-sized businesses. Through a GUI, users can configure and manage switch clusters or standalone switches. Cisco Network Assistant is available at no cost and can be downloaded from this URL:

http://www.cisco.com/en/US/products/ps5931/tsd_products_support_series_home.html

For information on starting the Cisco Network Assistant application, see the *Getting Started with Cisco Network Assistant* guide on Cisco.com.

- Device Manager

You can use the device manager, which is in the switch memory, to manage individual and standalone switches. This web interface offers quick configuration and monitoring. You can access the device manager from anywhere in your network through a web browser. For more information, see the getting started guide and the device manager online help.

- Cisco IOS CLI

The switch CLI is based on Cisco IOS software and is enhanced to support desktop-switching features. You can fully configure and monitor the switch. You can access the CLI either by connecting your management station directly to the switch management port, or a console port, or by using Telnet from a remote management station. See the switch command reference on Cisco.com for more information.

- CiscoWorks application

The CiscoWorks device-management application displays the switch image that you can use to set configuration parameters and to view the switch status and performance information. The CiscoView application, which you purchase separately, can be a standalone application or part of a Simple Network Management Protocol (SNMP) platform. See the CiscoView documentation for more information.

- SNMP network management

You can manage switches from a SNMP-compatible management station that is running platforms such as HP OpenView or SunNet Manager. The switch supports a comprehensive set of Management Information Base (MIB) extensions and four Remote Monitoring (RMON) groups. See the switch software configuration guide on Cisco.com and the documentation that came with your SNMP application for more information.

- Common Industrial Protocol

The Common Industrial Protocol (CIP) management objects are supported. The Cisco IE 3000 can be managed by CIP-based management tools, allowing the user to manage an entire industrial automation system with one tool.

Network Configurations

See the switch software configuration guide on Cisco.com for network configuration concepts and examples of using the switch to create dedicated network segments and interconnecting the segments through Gigabit Ethernet connections.



Switch Installation

This chapter describes how to install your switch, interpret the power-on self-test (POST), and connect the switch to other devices.



Caution

If your installation is in a hazardous environment, see [Appendix B, “Installation In a Hazardous Environment”](#) for instructions.

Read these topics, and perform the procedures in this order:

- [Preparing for Installation, page 2-1](#)
- [Adding Modules to the Switch, page 2-5](#)
- [Installing or Removing the Compact Flash Memory Card, page 2-12](#)
- [Verifying Switch Operation, page 2-13](#)
- [Installing the Switch, page 2-26](#)
- [Connecting Power and Alarm Circuits, page 2-36](#)
- [Connecting Destination Ports, page 2-40](#)
- [Connecting the Switch to the Power Converter, page 2-48](#)
- [Connecting the Switch to the AC-Input Power Supply, page 2-56](#)
- [Where to Go Next, page 2-58](#)

Preparing for Installation

This section provides information about these topics:

- [Warnings, page 2-2](#)
- [Installation Guidelines, page 2-3](#)
- [Verifying Package Contents, page 2-5](#)

Warnings

These warnings are translated into several languages in the Regulatory Compliance and Safety Information Guide.



Warning

Before working on equipment that is connected to power lines, remove jewelry (including rings, necklaces, and watches). Metal objects will heat up when connected to power and ground and can cause serious burns or weld the metal object to the terminals. Statement 43



Warning

Do not work on the system or connect or disconnect cables during periods of lightning activity. Statement 1001



Warning

Before performing any of the following procedures, ensure that power is removed from the DC circuit. Statement 1003



Warning

Read the installation instructions before you connect the system to its power source. Statement 1004



Warning

This unit is intended for installation in restricted access areas. A restricted access area can be accessed only through the use of a special tool, lock and key, or other means of security. Statement 1017



Warning

This equipment must be grounded. Never defeat the ground conductor or operate the equipment in the absence of a suitably installed ground conductor. Contact the appropriate electrical inspection authority or an electrician if you are uncertain that suitable grounding is available. Statement 1024



Warning

This unit might have more than one power supply connection. All connections must be removed to de-energize the unit. Statement 1028



Warning

Only trained and qualified personnel should be allowed to install, replace, or service this equipment. Statement 1030



Warning

Ultimate disposal of this product should be handled according to all national laws and regulations. Statement 1040



Warning

For connections outside the building where the equipment is installed, the following ports must be connected through an approved network termination unit with integral circuit protection. 10/100/1000 Ethernet Statement 1044

**Warning**

To prevent the system from overheating, do not operate it in an area that exceeds the maximum recommended ambient temperature of: 140°F (60°C) Statement 1047

**Warning**

Installation of the equipment must comply with local and national electrical codes. Statement 1074

**Warning**

To prevent airflow restriction, allow clearance around the ventilation openings to be at least: 4.13 in. (105 mm). Statement 1076

Installation Guidelines

When determining where to place the switch, observe these guidelines.

Environment and Enclosure Guidelines:

Review these environmental and enclosure guidelines before installation:

- This equipment is intended for use in a Pollution Degree 2 industrial environment, in overvoltage Category II applications (as defined in IEC publication 60664-1), at altitudes up to 9842 ft (3 km) without derating.
- This equipment is considered Group 1, Class A industrial equipment, according to IEC/CISPR Publication 11. Without appropriate precautions, there may be potential difficulties ensuring electromagnetic compatibility in other environments due to conducted as well as radiated disturbance.
- This equipment is supplied as open-type equipment. It must be mounted within an enclosure that is suitably designed for those specific environmental conditions that will be present and appropriately designed to prevent personal injury resulting from accessibility to live parts. The enclosure must have suitable flame-retardant properties to prevent or minimize the spread of flame, complying with a flame-spread rating of 5VA, V2, V1, V0 (or equivalent) if nonmetallic. The interior of the enclosure must be accessible only by the use of a tool. Subsequent sections of this publication might contain additional information regarding specific enclosure-type ratings that are required to comply with certain product safety certifications.

Other Guidelines

These are other installation guidelines:

**Caution**

Proper ESD protection is required whenever you handle Cisco equipment. Installation and maintenance personnel should be properly grounded by using ground straps to eliminate the risk of ESD damage to the switch.

Do not touch connectors or pins on component boards. Do not touch circuit components inside the switch. When not in use, store the equipment in appropriate static-safe packaging.

- Personnel responsible for the application of safety-related programmable electronic systems (PES) shall be aware of the safety requirements in the application of the system and shall be trained in using the system.
- This product is grounded through the DIN rail to chassis ground. Use zinc-plated yellow-chromate steel DIN rail to assure proper grounding. The use of other DIN rail materials (such as aluminum, plastic, and so on) that can corrode, oxidize, or are poor conductors can result in improper or intermittent grounding. Secure the DIN rail to the mounting surface approximately every 7.8 in. (200 mm), and use end-anchors appropriately.

When determining where to place the switch, observe these guidelines:

- Before installing the switch, first verify that the switch is operational by powering it on and running POST. Follow the procedures in the [“Verifying Switch Operation” section on page 2-13](#).
- For 10/100 ports and 10/100/1000 ports, the cable length from a switch to an attached device cannot exceed 328 feet (100 meters).
- For 100BASE-FX fiber-optic ports, the cable length from a switch to an attached device cannot exceed 6562 ft (2 km).
- For 100BASE-X SFP ports in the IEM-3000-4SM and the IEM-3000-8SM expansion modules, the cable length is dependent on the type of SFP installed in the port.
- Operating environment is within the ranges listed in [Appendix A, “Technical Specifications.”](#)
- Clearance to front and rear panels meets these conditions:
 - Front-panel LEDs can be easily read.
 - Access to ports is sufficient for unrestricted cabling.
 - Front-panel direct current (DC) power and relay connector is within reach of the connection to the DC power source.
- Airflow around the switch and through the vents is unrestricted. To prevent the switch from overheating, there must be the following minimum clearances:
 - Top and bottom: 4.13 in. (105 mm)
 - Exposed side (not connected to the module): 3.54 in. (90 mm)
 - Front: 2.56 in. (65 mm)
- Temperature surrounding the unit does not exceed 140°F (60°C).



Note When the switch is installed in an industrial enclosure, the temperature within the enclosure is greater than normal room temperature outside the enclosure.

The temperature inside the enclosure cannot exceed 140°F (60°C), the maximum ambient enclosure temperature of the switch.

- Cabling is away from sources of electrical noise, such as radios, power lines, and fluorescent lighting fixtures.
- Connect the unit only to a Class 2 DC power source.



Caution

This equipment is only suitable for use in Class I, Division 2, Groups A, B, C, D, or nonhazardous locations.

Verifying Package Contents

Carefully remove the contents from the shipping container, and check each item for damage. If any item is missing or damaged, contact your Cisco representative or reseller for support. Return all packing materials to the shipping container and save them.

The switch is shipped with these items:

- Documentation CD that includes:
 - *Cisco IE 3000 Switch Getting Started Guide* (in English, German, French, Spanish, Italian, Japanese, and simplified Chinese)
 - *Regulatory Compliance and Safety Information for the Cisco IE 3000 Switch*
- *Regulatory Compliance and Safety Information for the Cisco IE 3000 Switch* (safety warnings translated in German)
- Two power and relay connectors
- RJ-45 to DB-9 console port adapter cable

**Note**

To connect the switch functional ground, you need a ring terminal lug (such as Thomas & Bett part number RC10-14 or equivalent).

If you want to connect a terminal to the switch console port, you need to provide an RJ-45-to-DB-25 female DTE adapter. You can order a kit (part number ACS-DSBUASYN=) with that adapter from Cisco.

For multimode (MM) connections, you can connect a 100BASE-FX port to a port on a target device by using an dual-LC connector.

You can order a kit containing four spare latches (DINCLP-IE3000=) from Cisco.

Adding Modules to the Switch

The Cisco IE-3000-4TC or the Cisco IE-3000-8TC switch can operate as standalone devices with four or eight Fast Ethernet ports, respectively. To increase the number of Fast Ethernet ports by 8 or 16, you can connect the Cisco IEM-3000-8TM and the Cisco IEM-3000-8FM expansion modules. You can also add either 4 or 8 100BASE-X SFP ports by installing the Cisco IEM-3000-4SM or Cisco IEM-3000-8SM expansion modules. PoE-capable ports can also be added to the switch by installing either the IEM-3000-4PC or the IEM-3000-4PC-4TC PoE expansion modules. Depending on the mix of switches and expansion modules, you can have up to 24 Fast Ethernet ports.

**Note**

The expansion modules cannot operate as standalone devices.

Expansion Module Configurations

Both the IE-3000-4TC and the IE-3000-8TC can be configured with one or two expansion modules to increasing the number and type of ports for the switch. [Table 2-1](#) lists the supported port combinations of switch and expansion modules. The table also provides a breakdown of the type and quantity of ports for a particular switch expansion module configuration.

Table 2-1 Cisco IE-3000-4TC and Cisco IE-3000-8TC Switch Expansion Module Configurations and Port Types

| Expansion Module Configurations | | Port Types and Quantity (Including Switch Ports) | |
|---------------------------------|------------------------|--|---|
| Expansion Module 1 | Expansion Module 2 | IE-3000-4TC Switch | IE-3000-8TC Switch |
| — | — | 10/100FE—4 | 10/100FE—8 |
| Cisco IEM-3000-4PC | — | 10/100FE—4 10/100BASE-T—4 | 10/100FE—8 10/100BASE-T—4 |
| Cisco IEM-3000-4PC | Cisco IEM-3000-4PC | 10/100FE—4 10/100BASE-T—8 | 10/100FE—8 10/100BASE-T—8 |
| Cisco IEM-3000-4PC | Cisco IEM-3000-4PC-4TC | 10/100FE—4 10/100BASE-T—12 | 10/100FE—8 10/100BASE-T ² —12 |
| Cisco IEM-3000-4PC | Cisco IEM-3000-4SM | 10/100FE—4 100BASE-X—4 10/100BASE-T—4 | 10/100FE—8 100BASE-X—4 10/100BASE-T—4 |
| Cisco IEM-3000-4PC | Cisco IEM-3000-8FM | 10/100FE—4 100FX—8 10/100BASE-T—4 | 10/100FE—8 100FX—8 10/100BASE-T—4 |
| Cisco IEM-3000-4PC | Cisco IEM-3000-8SM | 10/100FE—4 100BASE-X—8 10/100BASE-T—4 | 10/100FE—8 100BASE-X—8 10/100BASE-T—4 |
| Cisco IEM-3000-4PC | Cisco IEM-3000-8TM | 10/100FE—12 10/100BASE-T—4 | 10/100FE—16 10/100BASE-T—4 |
| Cisco IEM-3000-4PC-4TC | — | 10/100FE—4 10/100BASE-T—8 | 10/100FE—8 10/100BASE-T—8 |
| Cisco IEM-3000-4PC-4TC | Cisco IEM-3000-4PC | 10/100FE—4 10/100BASE-T—12 | 10/100FE—8 10/100BASE-T—12 |
| Cisco IEM-3000-4PC-4TC | Cisco IEM-3000-4PC-4TC | 10/100FE—4 10/100BASE-T—16 | 10/100FE—8 10/100BASE-T—16 |
| Cisco IEM-3000-4PC-4TC | Cisco IEM-3000-4SM | 10/100FE—4 100BASE-X—4 10/100BASE-T—4 | 10/100FE—8 100BASE-X—4 10/100BASE-T—4 |
| Cisco IEM-3000-4PC-4TC | Cisco IEM-3000-8FM | 10/100FE—4 100FX—8 10/100BASE-T—8 | 10/100FE—8 100FX—8 10/100BASE-T—8 |
| Cisco IEM-3000-4PC-4TC | Cisco IEM-3000-8SM | 10/100FE—4 100BASE-X—8 10/100BASE-T—8 | 10/100FE—8 100BASE-X—8 10/100BASE-T—8 |
| Cisco IEM-3000-4PC-4TC | Cisco IEM-3000-8TM | 10/100FE—12 10/100BASE-T—8 | 10/100FE—16 10/100BASE-T—8 |
| Cisco IEM-3000-4SM | — | 10/100FE—4 100BASE-X—4 | 10/100FE—8 100BASE-X—4 |

Table 2-1 Cisco IE-3000-4TC and Cisco IE-3000-8TC Switch Expansion Module Configurations and Port Types (continued)

| Expansion Module Configurations | | Port Types and Quantity (Including Switch Ports) | |
|---------------------------------|------------------------|--|---|
| Expansion Module 1 | Expansion Module 2 | IE-3000-4TC Switch | IE-3000-8TC Switch |
| Cisco IEM-3000-4SM | Cisco IEM-3000-4PC | 10/100FE—4 100BASE-X—4 10/100BASE-T—4 | 10/100FE—8 100BASE-X—4 10/100BASE-T—4 |
| Cisco IEM-3000-4SM | Cisco IEM-3000-4PC-4TC | 10/100FE—4 100BASE-X—4 10/100BASE-T—8 | 10/100FE—8 100BASE-X—4 10/100BASE-T—8 |
| Cisco IEM-3000-4SM | Cisco IEM-3000-4SM | 10/100FE—4 100BASE-X—4 10/100BASE-T—4 | 10/100FE—8 100BASE-X—4 10/100BASE-T—4 |
| Cisco IEM-3000-4SM | Cisco IEM-3000-8FM | 10/100FE—4 100FX—8 100BASE-X—4 | 10/100FE—8 100FX—8 100BASE-X—4 |
| Cisco IEM-3000-4SM | Cisco IEM-3000-8SM | 10/100FE—4 100BASE-X—12 | 10/100FE—8 100BASE-X—12 |
| Cisco IEM-3000-4SM | Cisco IEM-3000-8TM | 10/100FE—12 100BASE-X—4 | 10/100FE—16 100BASE-X—4 |
| Cisco IEM-3000-8FM | — | 10/100FE—4 100FX—8 | 10/100FE—8 100FX—8 |
| Cisco IEM-3000-8SM | — | 10/100FE—4 100BASE-X—8 | 10/100FE—8 100BASE-X—8 |
| Cisco IEM-3000-8TM | — | 10/100FE—12 | 10/100FE—16 |
| Cisco IEM-3000-8TM | Cisco IEM-3000-4PC | 10/100FE—12 10/100BASE-T—4 | 10/100FE—16 10/100BASE-T—4 |
| Cisco IEM-3000-8TM | Cisco IEM-3000-4PC-4TC | 10/100FE—12 10/100BASE-T—8 | 10/100FE—16 10/100BASE-T—8 |
| Cisco IEM-3000-8TM | Cisco IEM-3000-4SM | 10/100FE—12 100BASE-X—4 | 10/100FE—16 100BASE-X—4 |
| Cisco IEM-3000-8TM | Cisco IEM-3000-8FM | 10/100FE—12 100FX—8 | 10/100FE—16 100FX—8 |
| Cisco IEM-3000-8TM | Cisco IEM-3000-8SM | 10/100FE—12 100BASE-X—8 | 10/100FE—16 100BASE-X—8 |
| Cisco IEM-3000-8TM | Cisco IEM-3000-8TM | 10/100FE—20 | 10/100FE—24 |



Caution

The four PoE ports on the expansion module can be configured as four PoE or four PoE+ (pending sufficient PoE power per modular) in the industrial control and hazardous location. The switch can only support up to two PoE+ ports per expansion module if installed in an office or computer IT room environment due to safety compliance IEC 60950.

Figure 2-1 shows four sample combinations of the Cisco IE-3000-4TC switch and expansion modules. A full list of combinations is contained in Table 2-1

**Note**

The switch and expansion module sample combinations illustrated in Figure 2-1 show an IE-3000-4TC switch. The same sample combinations could also be used with the Cisco IE-3000-8TC switch.

**Note**

Due to power constraints, a configuration that includes either IE 3000 switch and two IEM-3000-8SM expansion modules is not supported. Also, no expansion modules can be attached to the right of an IEM-3000-8SM expansion module.

Figure 2-1 Sample Combinations of Expansion Modules



| | | | |
|----------|--|----------|--|
| 1 | Cisco IE-3000-4TC switch with Cisco IEM-3000-8TM and Cisco IEM-3000-8FM expansion modules (12 FE and 8 FX ports) | 3 | Cisco IE-3000-4TC switch with one Cisco IEM-3000-8TM expansion module (12 FE ports) |
| 2 | Cisco IE-3000-4TC switch with one Cisco IEM-3000-8FM expansion module (4 FE and 8 FX ports) | 4 | Cisco IE-3000-4TC switch with two Cisco IEM-3000-8TM expansion modules (20 FE ports) |

Connecting Modules



Note

Expansion modules are not hot-swappable. You must turn off power to the switch before adding or removing an expansion module.

To connect the expansion modules to the switch, follow these steps:

- Step 1** Remove the side panel of the switch by firmly grasping both sides of it in the middle and pulling it outward. If necessary, use a screwdriver to pry open the side panel. See [Figure 2-2](#).

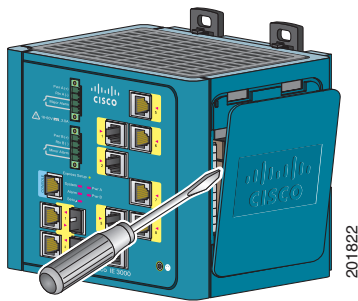
Figure 2-2 Opening the Side Panel of the Cisco IE-3000-8TC Switch



- Step 2** Remove the EMI protective cover from the interface connector on the switch. See [Figure 2-2](#).

Figure 2-3 Removing the EMI Cover

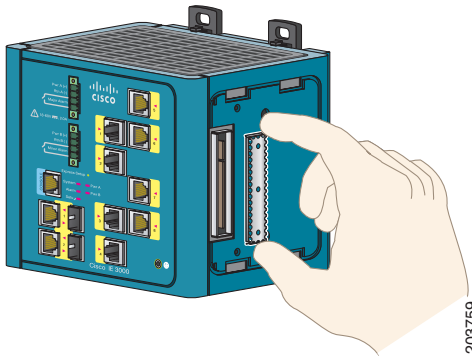

- Step 3** Push up the upper module latches (at the top of the switch and the expansion module). See [Figure 2-4](#). Push down the lower module latches (at the bottom of the switch and the expansion module).

Figure 2-4 Pushing the Module Latches Up

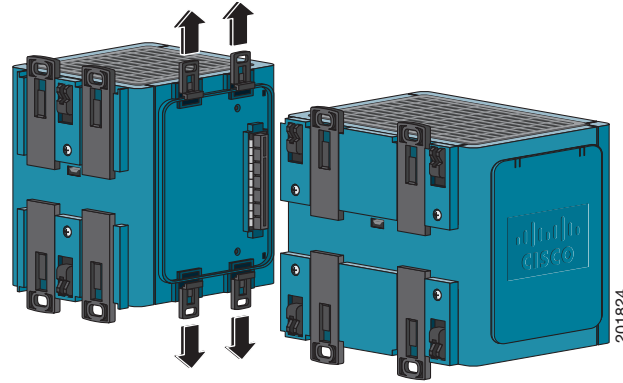

- Step 4** Align the connectors on the switch and the module, and slide the switch and the module together to make the connection. See [Figure 2-5](#).

Figure 2-5 Connecting the Switch and the Module

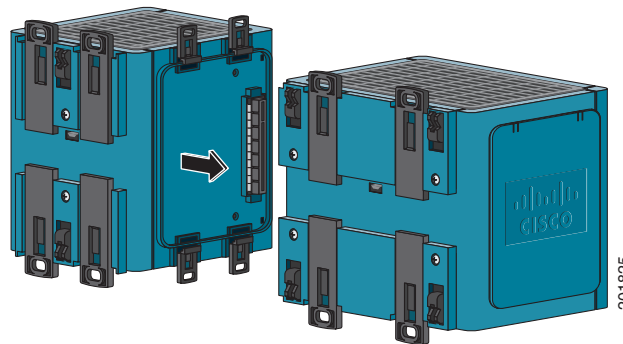

- Step 5** Push the upper module latches down and the lower latches up. See [Figure 2-6](#).

Figure 2-6 Pushing the Module Latches In

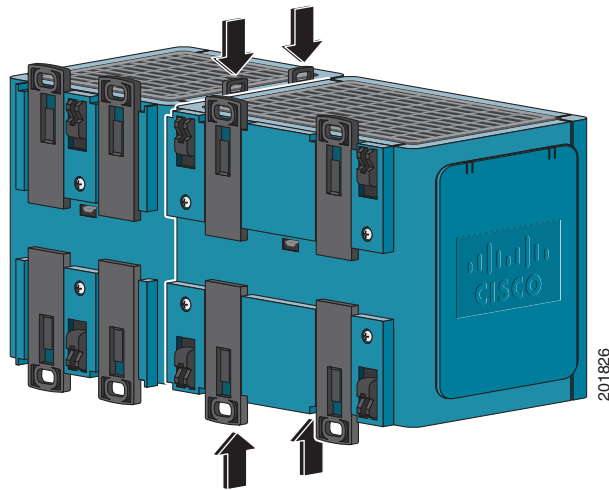

Step 6 If you are going to install a second expansion module to the switch expansion module combination, follow Step 1 through Step 5.



Note

Refer to [Table 2-1](#) for a list of supported switch and expansion module combinations.

If you are attaching an IEM-3000-4PC or IEM-3000-4PC-4TC PoE expansion module to the switch, you must also connect the expansion modules to source DC. Source DC can come from either the PWR-IE65W-PC-DC, a DC-input power supply, the PWR-IE65W-PC-AC, an AC-input power supply, or from site source DC; however, the site source power voltage must be 48-54VDC.

Installing or Removing the Compact Flash Memory Card

The switches store Cisco IOS software images and switch configurations on a removable flash memory card. You can replace the switch without reconfiguring it. The switch ships with the compact flash memory card installed. Verify that the card is in place on the bottom of the switch.

Follow these directions to remove or replace the compact flash memory card:

- Step 1** Locate the compact flash memory card slot on the bottom of the switch. See [Figure 2-7](#).

Figure 2-7 Removing the Compact Flash Memory Card from the Switch

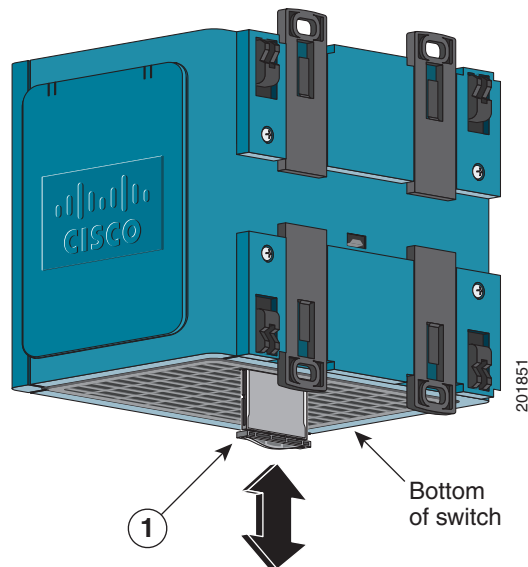

| | | | |
|----------|---------------------------|--|--|
| 1 | Compact flash memory card | | |
|----------|---------------------------|--|--|

- Step 2** Install or remove the card, as desired:
- To remove the card, grasp the card top, and pull it out. Place it in an antistatic bag to protect it from static discharge.
 - To install a card, slide it into the slot, and press it firmly in place. The card is keyed so that you cannot insert it the wrong way.

Verifying Switch Operation

Before installing the switch in its final location, power on the switch, and verify that the switch passes the power-on self-test (POST).

These sections describe the steps required to connect a PC or terminal to the switch console port, to power on the switch, and to observe POST results:

- [Connecting a PC or a Terminal to the Console Port, page 2-14](#)
- [Verifying Switch Operation, page 2-13](#)

Connecting a PC or a Terminal to the Console Port

To connect a PC to the console port, use the supplied RJ-45-to-DB-9 adapter cable. To connect a terminal to the console port, you need to provide an RJ-45-to-DB-25 female DTE adapter. You can order a kit (part number ACS-DSBUASYN=) with that adapter from Cisco. For console-port and adapter-pinout information, see the “[Cable and Adapter Specifications](#)” section on page C-5.

The PC or terminal must support VT100 terminal emulation. The terminal-emulation software—frequently a PC application such as HyperTerminal or Procomm Plus—makes communication between the switch and your PC or terminal possible during the POST.

Follow these steps to connect the PC or terminal to the switch:

Step 1 Make sure that your terminal-emulation software is configured to communicate with the switch using hardware flow control.

Step 2 Configure the baud rate and data format of the PC or terminal to match these console-port default characteristics:

- 9600 baud
- Eight data bits
- One stop bit
- No parity

After you get access to the switch, you can change the port baud rate. See the switch software configuration guide for instructions.

Step 3 Insert the adapter cable in the console port. See [Figure 2-8](#). (See the “[Cable and Adapter Specifications](#)” section on page C-5 for pinout descriptions.)

Figure 2-8 Connecting to the Console Port

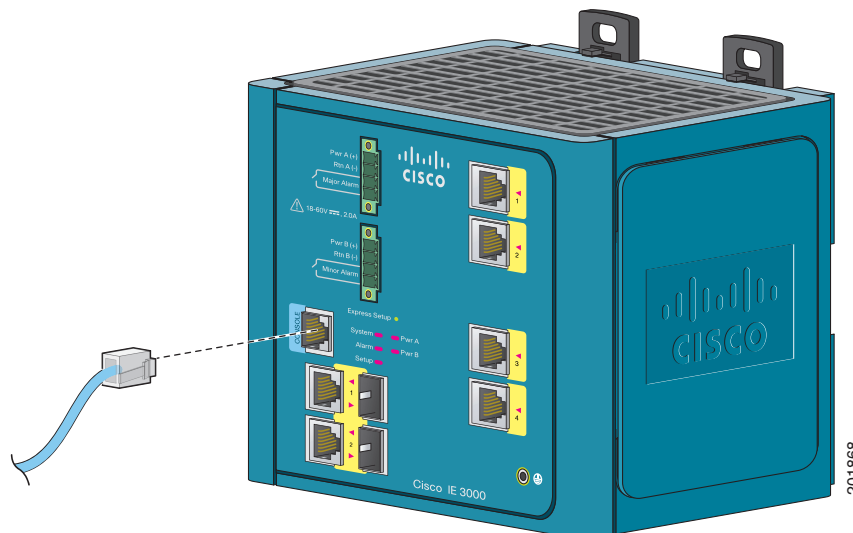

Step 4 Attach the appropriate adapter to the terminal, if needed.

- Step 5** Connect the other end of the adapter cable to the PC or terminal adapter.
- Step 6** Start the terminal-emulation software on the PC.
-

Connecting the Protective Ground and DC Power

These sections describe the steps required to connect a protective ground and DC power to the switch:

- [Grounding the Switch, page 2-15](#)
- [Wiring the DC Power Source, page 2-18](#)
- [Attach the Power and Relay Connector to the Switch, page 2-23](#)

**Note**

The Cisco IE 3000 switch can be used with an optional AC/DC power converter (PWR-IE3000-AC).

For instructions on how to connect the power converter to the switch, see the [“Connecting the Switch to the Power Converter” section on page 2-48](#).

Locate the power and relay connector in the switch accessory kit.

**Note**

You can get replacement power and relay connectors (PWR-IE3000-CNCT=) by calling Cisco Technical Support. See the [“Obtaining Documentation, Obtaining Support, and Security Guidelines” section on page viii](#).

Obtain these necessary tools and equipment:

- Ratcheting torque flathead screwdriver that can exert up to 15 inch-pounds (in-lb) of torque
- Ring terminal lug (such as Thomas & Bett part number 10RCR or equivalent)
- Crimping tool (such as Thomas & Bett part number WT2000, ERG-2001, or equivalent)
- 10-gauge copper ground wire (such as Belden part number 9912 or equivalent)
- For DC power connections, use UL- and CSA-rated, style 1007 or 1569 twisted-pair copper appliance wiring material (AWM) wire (such as Belden part number 9318).
- Wire-stripping tools for stripping 10- and 18-gauge wires

Grounding the Switch

To ground the switch to earth ground by using the ground screw, follow these steps. Make sure to follow any grounding requirements at your site.

**Warning**

This equipment must be grounded. Never defeat the ground conductor or operate the equipment in the absence of a suitably installed ground conductor. Contact the appropriate electrical inspection authority or an electrician if you are uncertain that suitable grounding is available. Statement 1024

**Warning**

This equipment is intended to be grounded to comply with emission and immunity requirements. Ensure that the switch functional ground lug is connected to earth ground during normal use. Statement 1064

**Caution**

To make sure that the equipment is reliably connected to earth ground, follow the grounding procedure instructions, and use a UL-listed ring terminal lug suitable for number 10-to-12 AWG wire, such as Thomas & Bett part number 10RCR or equivalent.

**Note**

Use at least a 4mm² conductor to connect to the external grounding screw.

Step 1 Use a standard Phillips screwdriver or a ratcheting torque screwdriver with a Phillips head to remove the ground screw from the front panel of the switch. Store the ground screw for later use.

Step 2 Use a wire-stripping tool to strip the 10-gauge wire to 0.5 inch. (12.7 mm) ± 0.02 inch (0.5 mm). See [Figure 2-9](#).

Figure 2-9 Stripping the Ground Wire

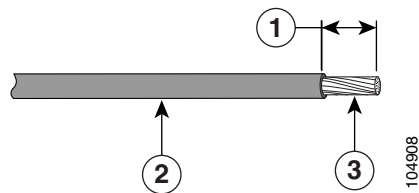

| | | | |
|----------|---------------------------------------|----------|-----------|
| 1 | 0.5 in. (12.7 mm) ± 0.02 in. (0.5 mm) | 3 | Wire lead |
| 2 | Insulation | | |

Step 3 Insert the ground wire into the ring terminal lug, and using a crimping tool, crimp the ring terminal to the wire.

Figure 2-10 Crimping the Ring Terminal

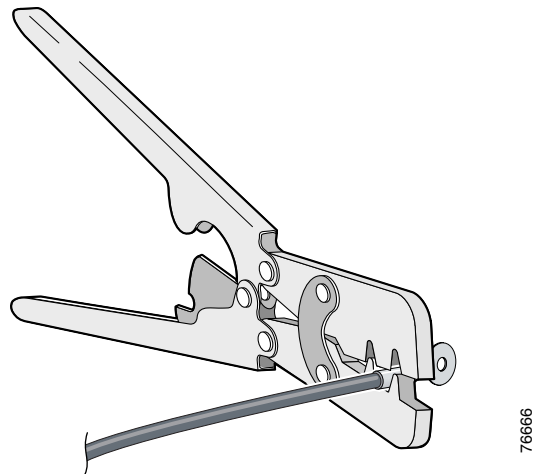

- Step 4** Slide the ground screw through the ring terminal.
- Step 5** Insert the ground screw into the functional ground screw opening on the front panel.
- Step 6** Use a ratcheting torque screwdriver to tighten the ground screw and ring terminal lug to the switch front panel to 8.5 in-lb. The torque should not exceed 8.5 in-lb (0.9 Nm). See [Figure 2-11](#).

Figure 2-11 Attaching the Ground-Lug Screw

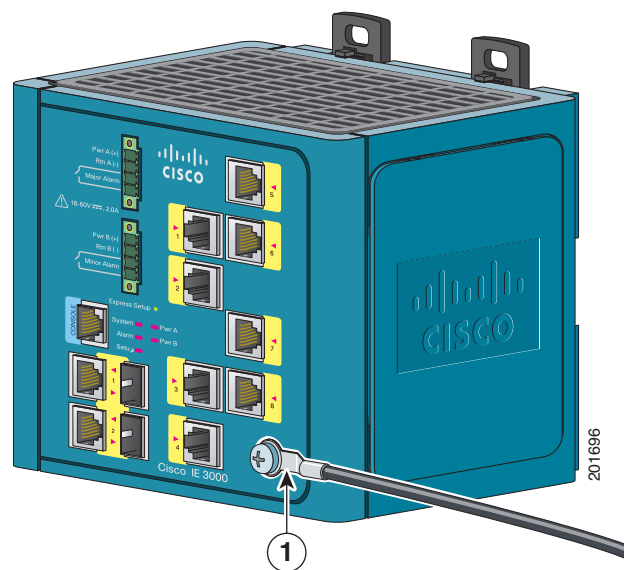

- | | |
|----------|-------------------------------------|
| 1 | Ground cable with ring terminal lug |
|----------|-------------------------------------|

- Step 7** Attach the other end of the ground wire to a grounded bare metal surface, such as a ground bus, a grounded DIN rail, or a grounded bare rack.

Wiring the DC Power Source

Read these warnings before wiring the DC power source:



Caution

This product is intended to be powered by a Listed Class 2 power source marked with "Class 2" and rated from 18 to 60 VDC \pm 0 VDC, 2.1 A.



Warning

A readily accessible two-poled disconnect device must be incorporated in the fixed wiring. Statement 1022



Warning

This product relies on the building's installation for short-circuit (overcurrent) protection. Ensure that the protective device is rated not greater than: 5A. Statement 1005



Warning

Installation of the equipment must comply with local and national electrical codes. Statement 1074



Warning

Before performing any of the following procedures, ensure that power is removed from the DC circuit. Statement 1003



Warning

Only trained and qualified personnel should be allowed to install, replace, or service this equipment. Statement 1030



Caution

You must connect the switch only to a DC-input power source that has an input supply voltage from 18 to 60 VDC \pm 0 VDC. If the supply voltage is not in this range, the switch might not operate properly or might be damaged.



Caution

For wire connections to the power and relay connector, you must use UL- and CSA-rated, style 1007 or 1569 twisted-pair copper appliance wiring material (AWM) wire (such as Belden part number 9318).

To wire the switch to the optional AC/DC converter, go to the [“Connecting the Switch to the Power Converter”](#) section on page 2-48.

To wire the switch to a DC-input power source, follow these steps:

- Step 1** Locate the power and relay connector (see [Figure 2-12](#)).

Figure 2-12 Power and Relay Connector

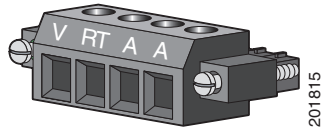

- Step 2** Identify the positive and return DC power connections on the connector. The positive DC power connection is labeled V, and the return is the adjacent connection labeled RT. See [Figure 2-12](#).
- Step 3** Measure two strands of twisted-pair copper wire (18-to-20 AWG) long enough to connect to the DC power source.
- Step 4** Using an 18-gauge wire-stripping tool, strip each of the two twisted pair wires coming from each DC-input power source to 0.25 inch (6.3 mm) \pm 0.02 inch (0.5 mm). Do not strip more than 0.27 inch (6.8 mm) of insulation from the wire. Stripping more than the recommended amount of wire can leave exposed wire from the power and relay connector after installation.

Figure 2-13 Stripping the Power Connection Wire

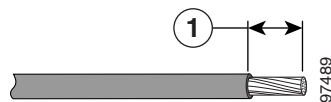

| | |
|----------|---|
| 1 | 0.25 in. (6.3 mm) \pm 0.02 in. (0.5 mm) |
|----------|---|

- Step 5** Insert the exposed part of the positive wire into the connection labeled V and the exposed part of the return wire into the connection labeled RT. See [Figure 2-14](#). Make sure that you cannot see any wire lead. Only wire *with insulation* should extend from the connector.



Warning

An exposed wire lead from a DC-input power source can conduct harmful levels of electricity. Be sure that no exposed portion of the DC-input power source wire extends from the power and relay connector. Statement 122

Figure 2-14 Inserting Wires in the Power and Relay Connector

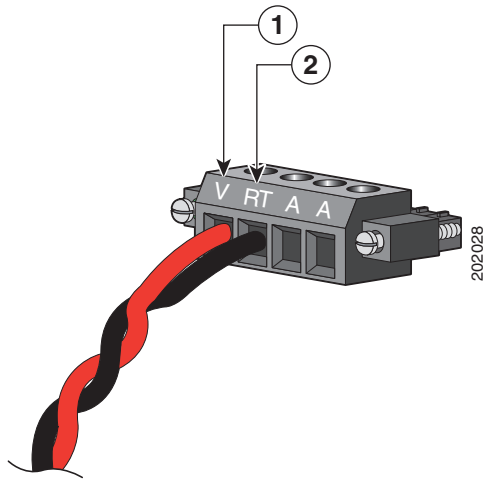

| | | | |
|----------|----------------------------------|----------|--------------------------------|
| 1 | Power source positive connection | 2 | Power source return connection |
|----------|----------------------------------|----------|--------------------------------|

Step 6 Use a ratcheting torque flathead screwdriver to torque the power and relay connector captive screws (above the installed wire leads) to 2.2 in-lb (0.25 Nm). See [Figure 2-15](#).



Caution

Do not over-torque the power and relay connector captive screws. The torque should not exceed 2.2 in-lb (0.25 Nm).

Figure 2-15 Torquing the Power and Relay Connector Captive Screws

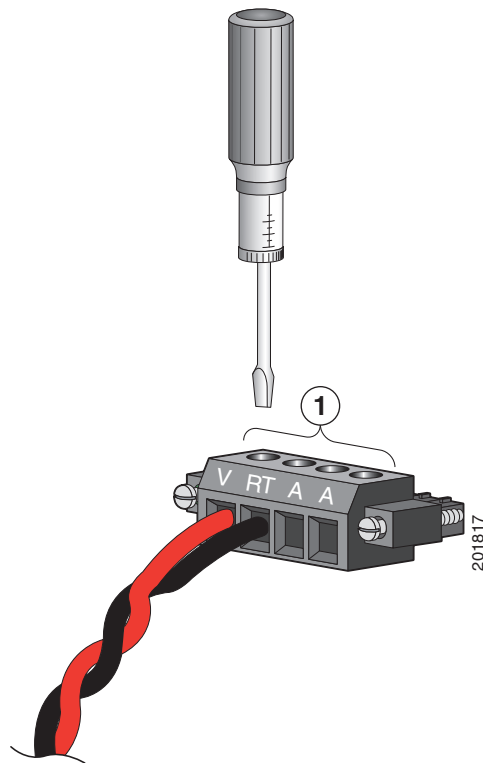

1 Power and relay connector captive screws

Step 7 Connect the other end of the positive wire (the one connected to V) to the positive terminal on the DC power source, and connect the other end of the return wire (the one connected to RT) to the return terminal on the DC power source.

When you are testing the switch, one power connection is sufficient. If you are installing the switch and are using a second power source, repeat [Step 4](#) through [Step 7](#) using a second power and relay connector.

[Figure 2-16](#) shows the completed DC-input wiring on a power and relay connector for a primary power source and an optional secondary power source.

Figure 2-16 Completed DC Power Connections on the Power and Relay Connector

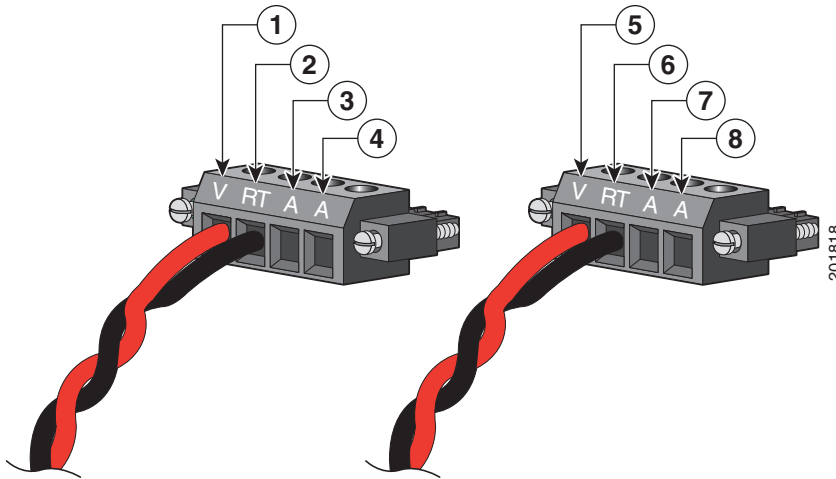

| | | | |
|----------|--|----------|--|
| 1 | Power source A positive connection | 5 | Power source B positive connection |
| 2 | Power source A return connection | 6 | Power source B return connection |
| 3 | External device 1, relay wire connection | 7 | External device 2, relay wire connection |
| 4 | External device 1, relay wire connection | 8 | External device 2, relay wire connection |

If your power source is -48 VDC, the following table describes the your wiring connections for [Figure 2-16](#).

| | | | |
|----------|--|----------|--|
| 1 | Power source A return connection | 5 | Power source B return connection |
| 2 | Power source A -48 VDC connection | 6 | Power source B -48 VDC connection |
| 3 | External device 1, relay wire connection | 7 | External device 2, relay wire connection |
| 4 | External device 1, relay wire connection | 8 | External device 2, relay wire connection |

Step 8 (Optional) If you plan to connect external alarm devices to the alarm relays and the switch is already installed, go to the [“Wiring the External Alarms”](#) section on page 2-37. Otherwise, go to the [“Verifying Switch Operation”](#) section on page 2-13.

Attach the Power and Relay Connector to the Switch

To attach the power and relay connectors to the front panel of the switch, follow these steps:

- Step 1** Insert the power and relay connector into the Pwr A receptacle on the switch front panel. See [Figure 2-17](#).

Figure 2-17 Connecting the Power and Relay Connector to the Switch

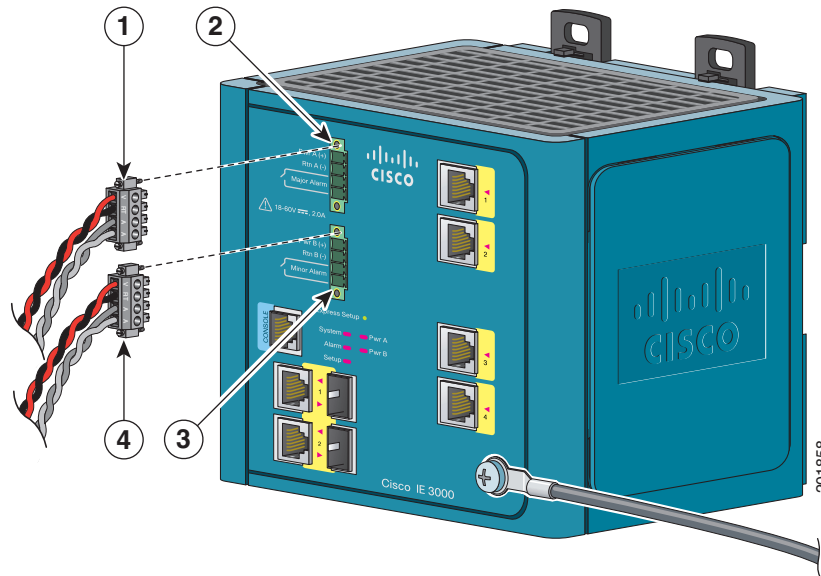

| | | | |
|----------|--------------------------|----------|--------------------------|
| 1 | Power source A connector | 3 | Pwr B receptacle |
| 2 | Pwr A receptacle | 4 | Power source B connector |

- Step 2** Use a ratcheting torque flathead screwdriver to tighten the captive screws on the sides of the power and relay connector.

When you are testing the switch, one power source is sufficient. If you are installing the switch and are using a second power source, repeat this procedure for the second power and relay connector (Pwr B), which installs just below the primary power connector (Pwr A).

When you are installing the switch, secure the wires coming from the power and relay connector so that they cannot be disturbed by casual contact. For example, use tie wraps to secure the wires to the rack.

Attaching DC Power to the PoE Expansion Modules

If your switch configuration includes either the IEM-3000-4PC or the IEM-3000-4PC-4TC PoE expansion modules, you must attach source DC directly to the expansion module's Input DC terminal block. Source DC can come from either the PWR-IE65W-PC-DC, a DC-input power supply, the PWR-IE65W-PC-AC, an AC-input power supply, or from site source DC; however, site source power voltage must be 48–54VDC.

If you are using the above Cisco PoE AC/DC power supplies, you can power up to 4 PoE or 2 PoE+ devices on each expansion module.

To attach site source DC to the expansion module:



Warning

The equipment is to be connected to a UL Listed, limited power source. Statement 170



Note

Warning statement 170 is applicable only to office/computer room environments (IEC 60950).

-
- Step 1** Verify that power is off to the DC circuit you are going to attach to the DC-input power supply. As an added precaution, place the appropriate safety flag and lockout devices at the source power circuit breaker, or place a piece of adhesive tape over the circuit breaker handle to prevent accidental power restoration while you are working on the circuit.
- Step 2** Measure a length of twisted-pair copper wire long enough to connect the site source DC to the PoE expansion module's Input DC terminal block.
- For DC connections from the site source DC to the PoE expansion module, use 18-AWG (0.75 mm²) twisted-pair copper wire, such as Belden part number 9344 or the appropriate type, wire size, and color-code for your country.
- Step 3** Using a wire-stripping tool, strip both ends of the twisted pair wires to 0.25 inch (6.3 mm) ± 0.02 inch (0.5 mm). Do not strip more than 0.27 inch (6.8 mm) of insulation from the wires.
- Step 4** Attach the twisted-pair wire leads into the site source DC positive (+) and negative (-) connectors. Verify that only insulated wire extends from the connectors.
- Step 5** Secure the twisted-pair leads to the source DC connectors.
- Step 6** Connect the other end of the twisted-pair wire leads to the Input DC terminal block connectors on the PoE expansion module making sure that only insulated wire extends beyond the terminal block.

Verify that the positive (+) wire goes from the source DC positive (+) connector to the positive (+) connector on the expansion module and that the source DC negative (-) wire goes to the negative (-) connector on the expansion module.

- Step 7** Secure the twisted-pair leads to the terminal block connectors using the torque ratchet screwdriver to tighten the expansion module terminal block screws.



Note

Do not overtighten the terminal block screws. The torque on the screws should not exceed 2.2 in-lb (0.25 Nm).

- Step 8** When you are ready to power up the switch, remove the safety flag and lockout devices from the PoE expansion module DC circuit and turn on the power to power up the module.
-

Running POST

When the switch powers on, it automatically initiates a POST. The POST runs a series of tests that verify that the switch functions properly and ensures that it is ready to install. To test the switch, follow these steps:

- [Applying Power to the Switch, page 2-25](#)
- [Verify POST Results, page 2-25](#)
- [Disconnect Power, page 2-26](#)

Applying Power to the Switch

To apply power to a switch that is directly connected to a DC power source, locate the circuit breaker on the panel board that services the DC circuit, and switch the circuit breaker to the ON position.

**Note**

For instructions on how to apply power to a switch that is connected to a power converter, see the [“Applying Power to the Power Converter”](#) section on page 2-56.

If you have installed a PoE expansion module (either IEM-3000-4PC or IEM-3000-4PC-4TC) to the switch, you must attach DC power directly to the expansion module. DC power can be either from site source DC (verify that source DC power meets the power input requirements of the expansion module) or from a separate DC-power supply (PWR-IE65W-PC-DC or PWR-IE65W-PC-AC). If your switch configuration consists of two PoE expansion modules, you must connect each PoE expansion module to a separate power supply. For instructions on how to connect the DC-input power supply to the PoE expansion module, refer to the Cisco IE 3000 65 W DC-Input Power Supply Installation Note available on [cisco.com](#). For instructions on how to connect the AC-input power supply to the PoE expansion module, refer to the Cisco IE 3000 65 W AC-Input Power Supply Installation Note available on [cisco.com](#).

Verify POST Results

When you power on the switch, it automatically begins POST. All LEDs are off for a few seconds, and then each LED is tested. One at a time, the System, Alarm, Setup, Pwr A, and Pwr B LEDs each briefly turn green, then red, and then go off. The System LED blinks green as the boot loader verifies the basic functionality of the processing and memory hardware. Assuming all tests pass, the System LED continues to blink green as the Cisco IOS software image loads. If the POST fails, the System LED turns red.

**Note**

POST failures are usually fatal. Call Cisco Systems immediately if your switch does not pass POST. See the [“Obtaining Documentation, Obtaining Support, and Security Guidelines”](#) section on page viii.

Disconnect Power

After successfully running POST, follow these steps.

-
- Step 1** Turn off power to the switch.
- Step 2** Disconnect the cables.
- Step 3** Decide where you want to install the switch.
-

Installing the Switch

This section describes how to install the switch:

- [Installing the Switch on a DIN Rail](#)
- [Installing the Switch on the Wall](#)
- [Installing the Switch in a Rack](#)



Warning

This equipment is supplied as “open type” equipment. It must be mounted within an enclosure that is suitably designed for those specific environmental conditions that will be present and appropriately designed to prevent personal injury resulting from accessibility to live parts. The interior of the enclosure must be accessible only by the use of a tool.

The enclosure must meet IP 54 or NEMA type 4 minimum enclosure rating standards. Statement 1063



Caution

To prevent the switch from overheating, ensure these minimum clearances:

- Top and bottom: 4.13 in. (105 mm)
 - Exposed side (not connected to the module): 3.54 in. (90 mm)
 - Front: 2.56 in. (65 mm)
-

Installing the Switch on a DIN Rail

The switch ships with latches on the rear panel for a mounting on a DIN rail. See [Figure 2-18](#).

Figure 2-18 Cisco IE 3000 Switch Rear Panel

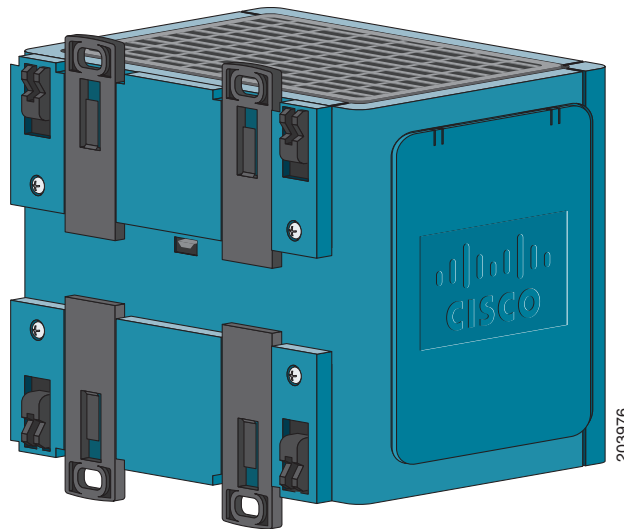

You can install the switch as a standalone device on the DIN rail or with the expansion modules already connected. You must connect expansion modules to the switch before installing the switch on the DIN rail. To connect the modules to the switch, follow the steps described in the [“Adding Modules to the Switch”](#) section on page 2-5.

The illustrations in this procedure show how to install the switch as a standalone device. The same steps can be used to install a switch with expansion modules on the DIN rail.

To attach the switch to a DIN rail, follow these steps.

- Step 1** Use a flathead screwdriver to press in the space next to the tab on each of the latches and turn the screwdriver clockwise. See [Figure 2-19](#).

Figure 2-19 *Unlock the Switch Latch*

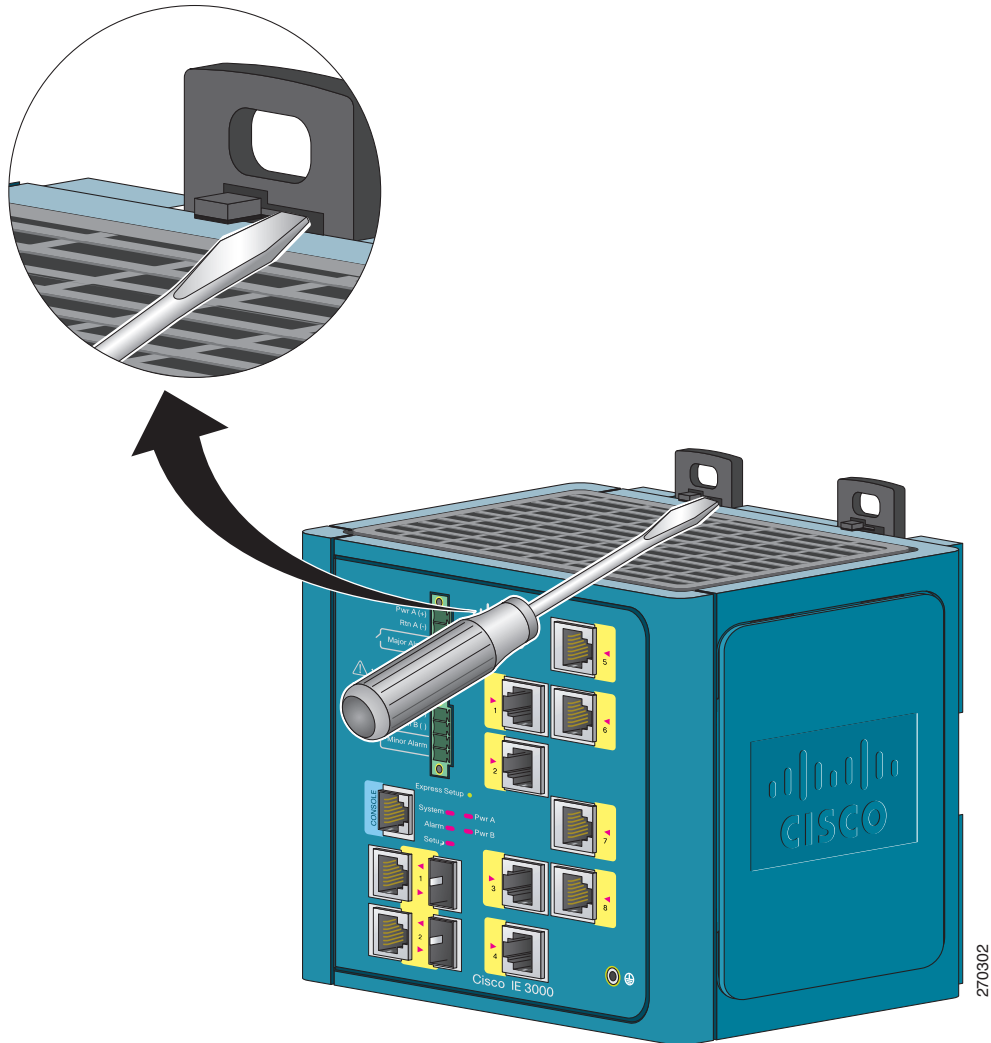

Step 2 Push out on the DIN rail latches. See [Figure 2-20](#).

Figure 2-20 Pushing the DIN Rail Latches Out

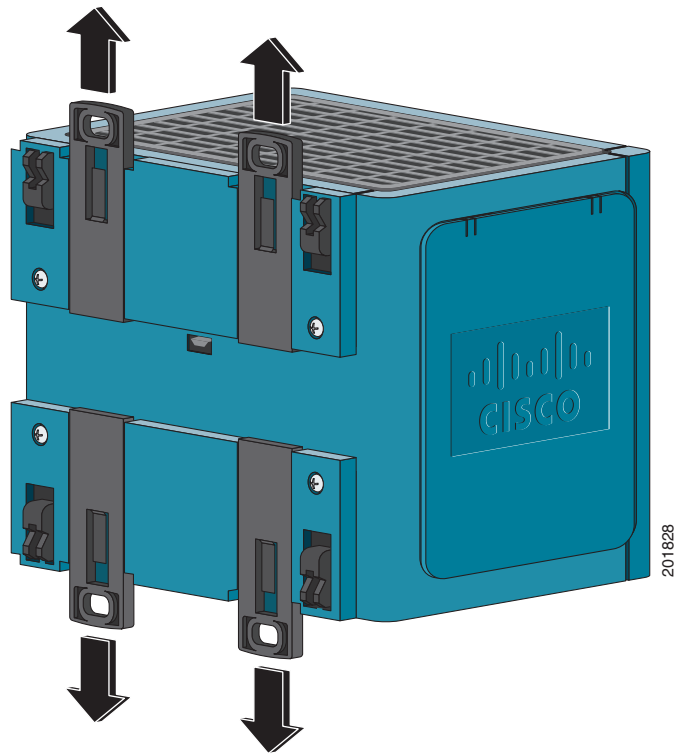

Step 3 Position the rear panel of the switch directly in front of the DIN rail, making sure that the DIN rail fits in the space between the two latches.

Step 4 Push the DIN rail latches in after the switch is over the DIN rail. See [Figure 2-21](#).

Figure 2-21 Pushing the DIN Rail Latches In

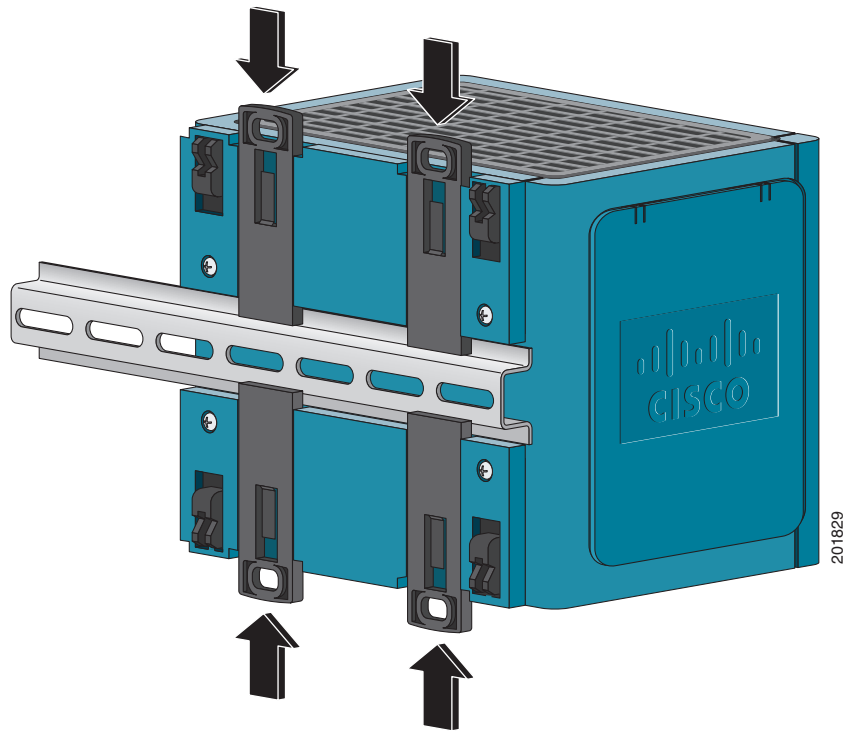

Note

If you are using a 15-mm DIN rail, rotate all of the feet (see [Figure 2-21](#)) to the extended positions. Otherwise, rotate all of the feet to the recessed positions. [Figure 2-22](#) shows the two DIN rails. You can use either the 7.5-mm or the 15-mm DIN rail.

Figure 2-22 Mounting the Switch on a DIN Rail in a Parallel Position

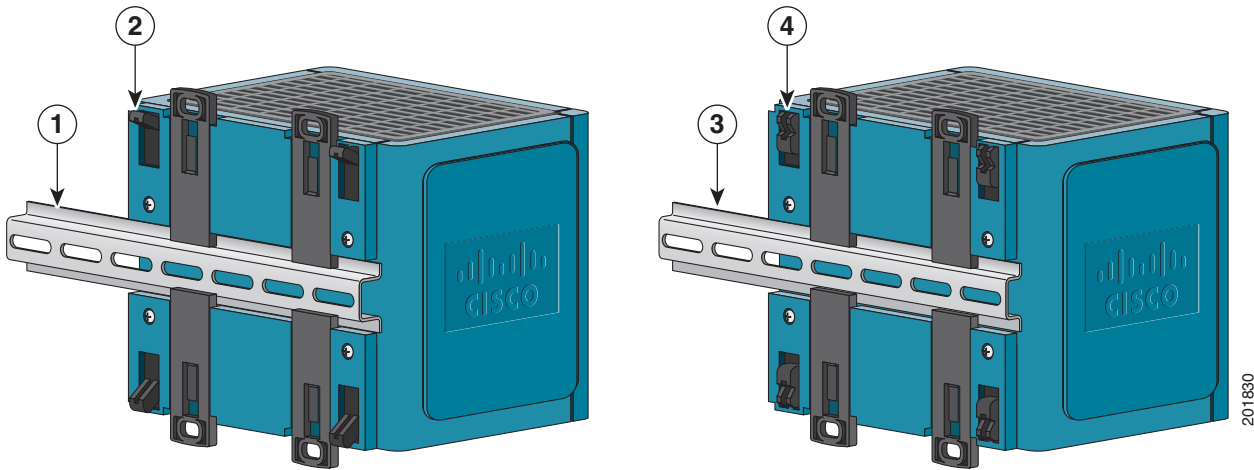

| | | | |
|----------|---------------------------|----------|---------------------------|
| 1 | 15-mm DIN rail | 3 | 7.5-mm DIN rail |
| 2 | Foot in extended position | 4 | Foot in recessed position |

After the switch is mounted on the DIN rail, connect the power and alarm wires, as described in the “[Connecting Power and Alarm Circuits](#)” section on page 2-36.



Note

For instructions on how to remove the switch from a DIN rail, see the “[Removing the Switch from a DIN Rail or a Rack](#)” section on page 2-35.

Installing the Switch on the Wall

To attach the switch to a wall or a panel, follow these steps.



Warning

Read the wall-mounting instructions carefully before beginning installation. Failure to use the correct hardware or to follow the correct procedures could result in a hazardous situation to people and damage to the system. Statement 378

- Step 1** If the DIN rail latches are pushed out, push in the DIN rail latches. See [Figure 2-23](#).

Figure 2-23 Pushing the DIN Rail Latches In

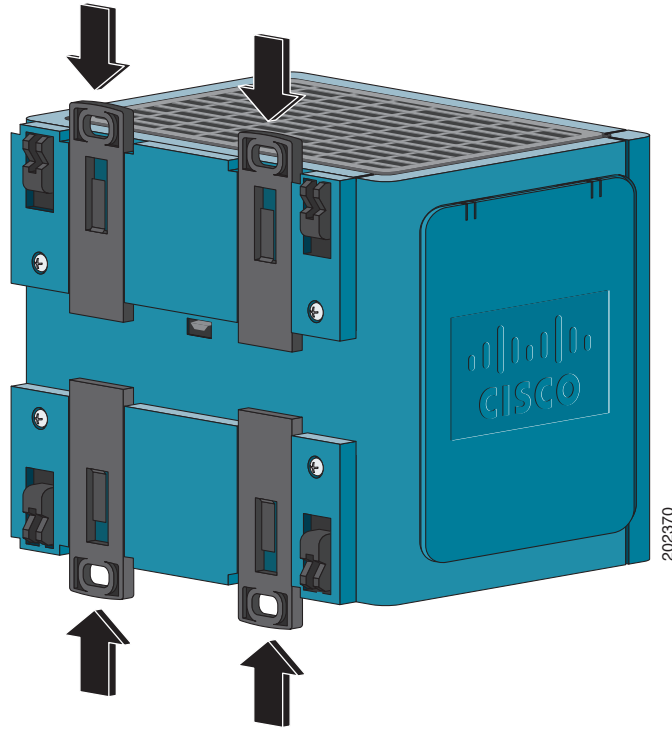

- Step 2** Rotate all feet to the recessed positions so that the switch can mount flat on the wall or panel. See [Figure 2-22](#).
- Step 3** Position the rear panel of the switch against the wall or a panel in the desired location. See [Figure 2-24](#).

Figure 2-24 Mounting the Switch on the Wall

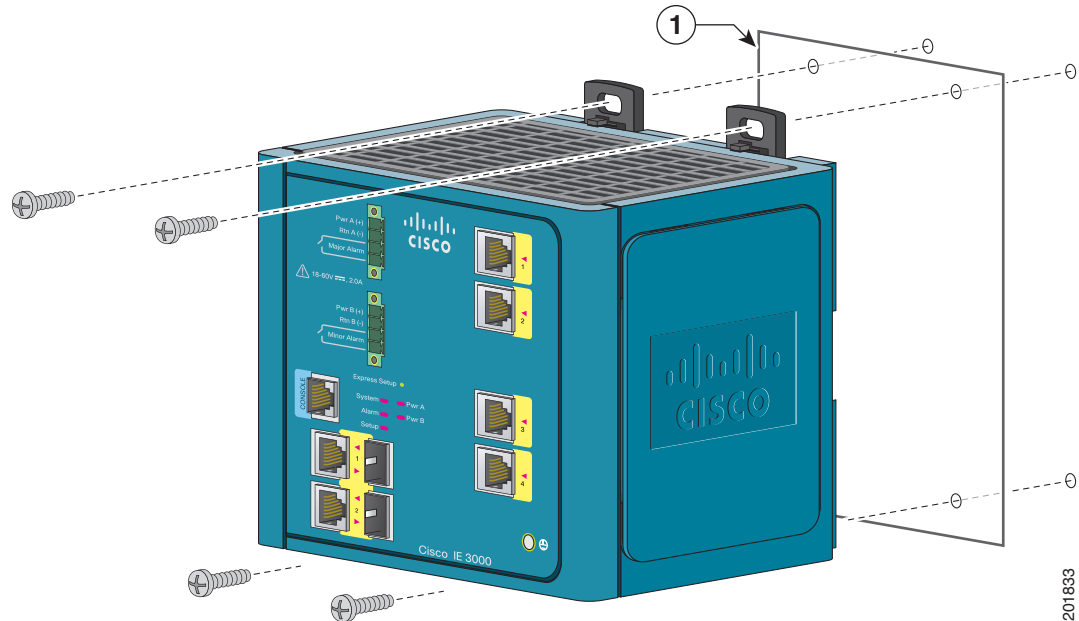

- Step 4** Place a number-10 screw that you provide through each DIN rail latch, and screw them into the wall.

| | |
|----------|------|
| 1 | Wall |
|----------|------|

After the switch is mounted on the wall or panel, connect the power and alarm wires, as described in the [“Connecting Power and Alarm Circuits”](#) section on page 2-36.

Installing the Switch in a Rack

You can use an optional DIN rail adapter kit (available through Cisco, part number STK-RACKMNT-2955=) to mount the switch in a 19-inch rack. The rack-mounting kit comes with a DIN rail adapter and screws to attach the adapter to the rack. Ask your Cisco representative for details.

**Warning**

To prevent bodily injury when mounting or servicing this unit in a rack, you must take special precautions to ensure that the system remains stable. The following guidelines are provided to ensure your safety:

- This unit should be mounted at the bottom of the rack if it is the only unit in the rack.
- When mounting this unit in a partially filled rack, load the rack from the bottom to the top with the heaviest component at the bottom of the rack.
- If the rack is provided with stabilizing devices, install the stabilizers before mounting or servicing the unit in the rack. **Statement 1006**

**Note**

The 19-inch rack adapter is not intended for application in an industrial environment and therefore it will not meet the environmental performance specifications for the Cisco IE 3000 switch.

To install the switch in a rack, follow these steps:

- Step 1** Use the four Phillips machine screws to securely attach the brackets to the rack. See [Figure 2-25](#).

Figure 2-25 *Installing the DIN Rail on the Rack*

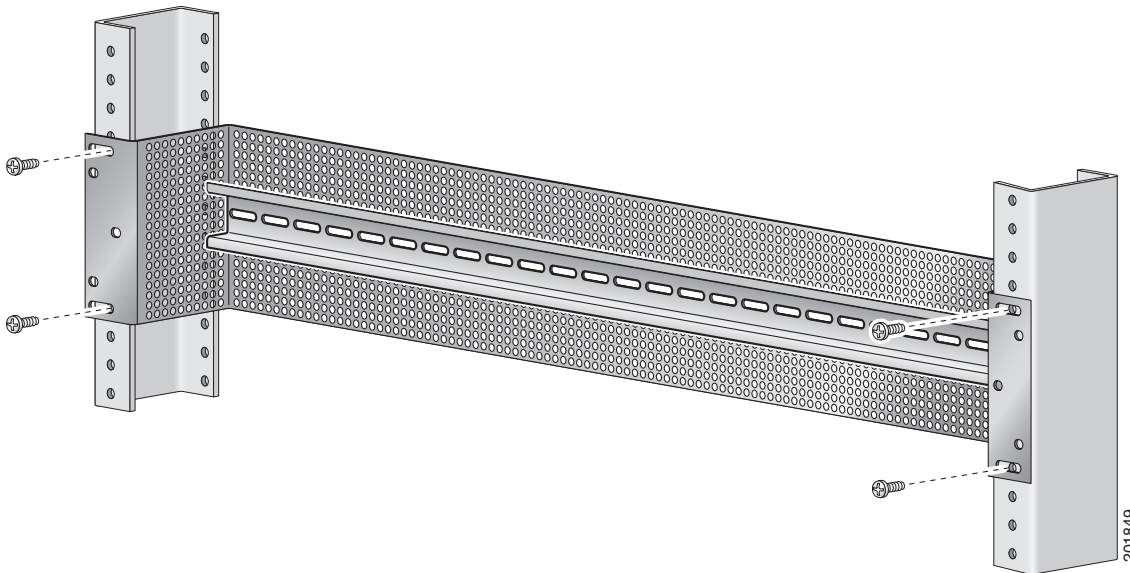

- Step 2** Follow the steps described in the [Installing the Switch on a DIN Rail](#), page 27.

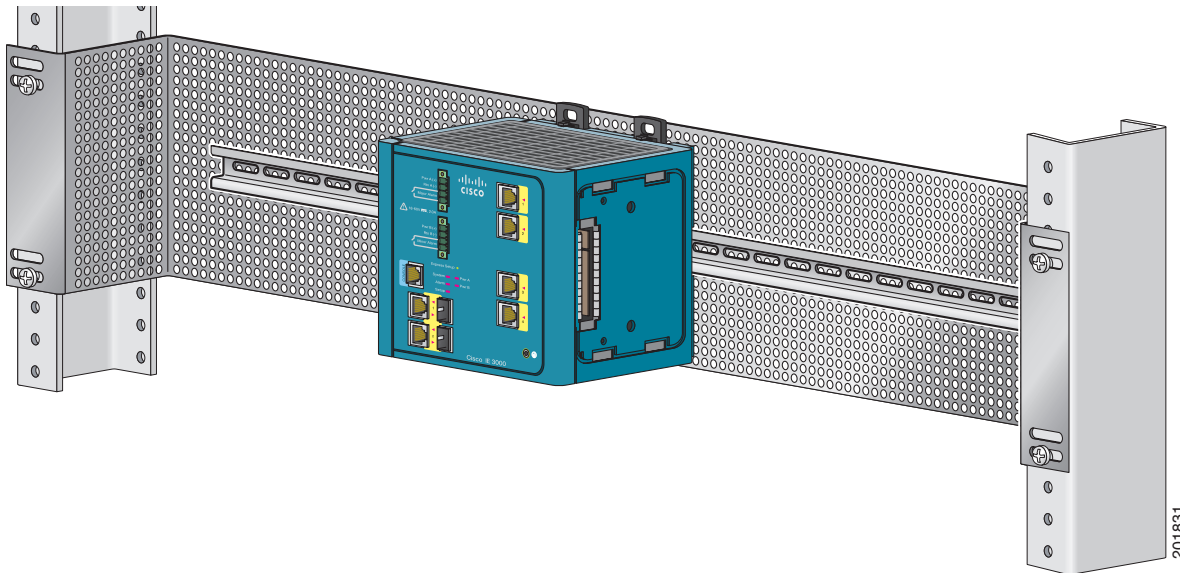
Figure 2-26 Installing the Switch on a Rack

After the switch is mounted in the rack, connect the power and alarm wires, as described in the [“Connecting Power and Alarm Circuits”](#) section on page 2-36.

For instructions on how to remove the switch from a rack, see the [“Removing the Switch from a DIN Rail or a Rack”](#) section on page 2-35.

Removing the Switch from a DIN Rail or a Rack

To remove the switch from a DIN rail or a rack, follow these steps:

- Step 1** Ensure that power is removed from the switch, and disconnect all cables and connectors from the front panel of the switch.
- Step 2** Use a tool such as a flathead screw driver to press in the space next to the tab on each of the latches and turn the screw driver clockwise. See [Figure 2-19](#).
- Step 3** Push the DIN rail latches at the top of the switch up, and the latches at the bottom of the switch down. Pull the switch out, and release the switch from the DIN rail. See [Figure 2-27](#).

Figure 2-27 Removing the Switch from the DIN Rail

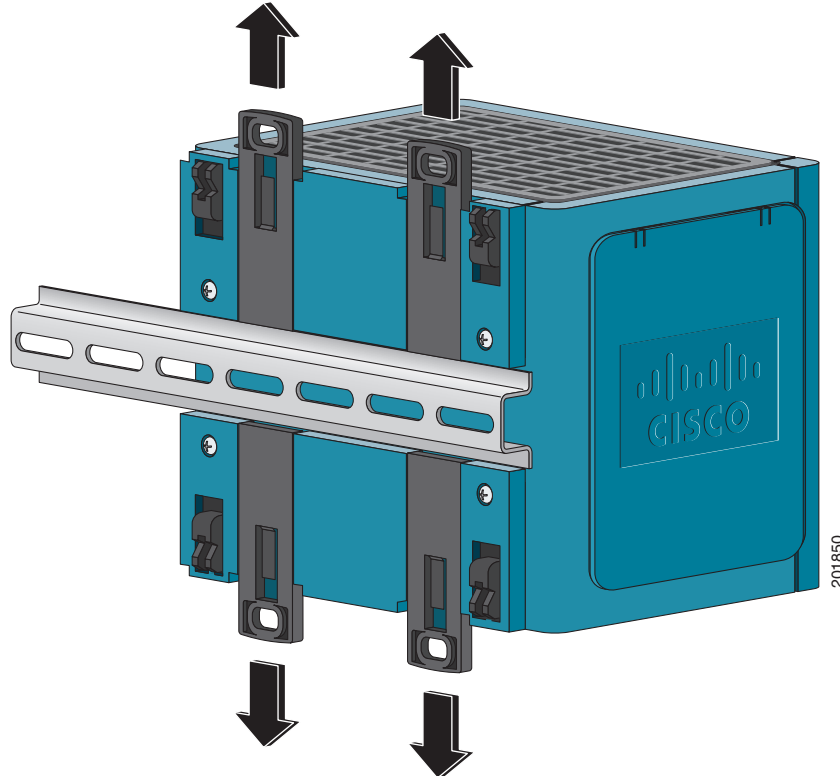

Step 4 Remove the switch from the DIN rail.

Connecting Power and Alarm Circuits

After the switch is installed, you are ready to connect the DC power and alarm relays.

- [Wiring the Protective Ground and DC Power, page 2-36](#)
- [Wiring the External Alarms, page 2-37](#)

Wiring the Protective Ground and DC Power



Note

The switch can use either a dual or single positive DC input (24V/48V), or a single negative DC input (-24V/-48V). Dual negative DC inputs are not supported.

For instructions on grounding the switch and connecting the DC power, see the [“Connecting the Protective Ground and DC Power”](#) section on page 2-15.

For instructions on using a power converter for DC power, see the [“Connecting the Switch to the Power Converter”](#) section on page 2-48.

Wiring the External Alarms

The alarm relays on the switch are normally open. To connect an external alarm device to the relays, you must connect two relay contact wires to complete an electrical circuit. Because each external alarm device requires two connections to a relay, the switch supports a maximum of two external alarm devices. This procedure is optional.



Caution

The input voltage source of the alarm circuits must be an isolated source and limited to less than or equal to 24 VDC, 1 A.



Note

Wire connections to the power and relay connector, must be UL- and CSA-rated, style 1007 or 1569 twisted-pair copper appliance wiring material (AWM) wire (such as Belden part number 9318).

To wire the switch to an external alarm device, follow these steps:

- Step 1** Measure two strands of twisted-pair wire (18-to-20 AWG) long enough to connect to the external alarm device.
- Step 2** Use a wire stripper to remove the casing from both ends of each wire to 0.25 inch (6.3 mm) \pm 0.02 inch (0.5 mm). Do not strip more than 0.27 inch (6.8 mm) of insulation from the wires. Stripping more than the recommended amount of wire can leave exposed wire from the power and relay connector after installation.
- Step 3** Insert the exposed wires for the external alarm device into the two connections labeled A. See [Figure 2-28](#).

Figure 2-28 Inserting Relay Wires into the Power and Relay Connector

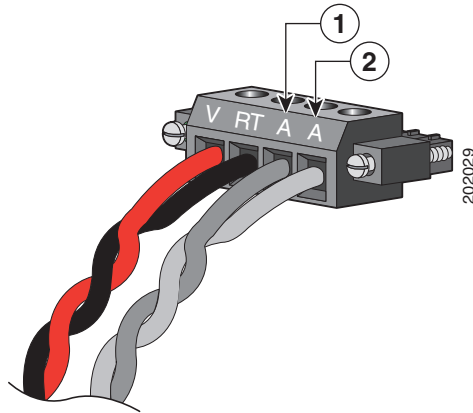

| | | | |
|----------|--|----------|--|
| 1 | External device, relay wire A connection 1 | 2 | External device, relay wire A connection 2 |
|----------|--|----------|--|

- Step 4** Use a ratcheting torque flathead screwdriver to torque the power and relay connector captive screw (above the installed wire leads) to 2 in-lb (0.22 Nm). See [Figure 2-29](#) for details.

**Caution**

Do not over-torque the power and relay connector captive screws. The torque should not exceed 2.2 in-lb (0.25 Nm).

Figure 2-29 Torquing the Power and Relay Connector Captive Screws

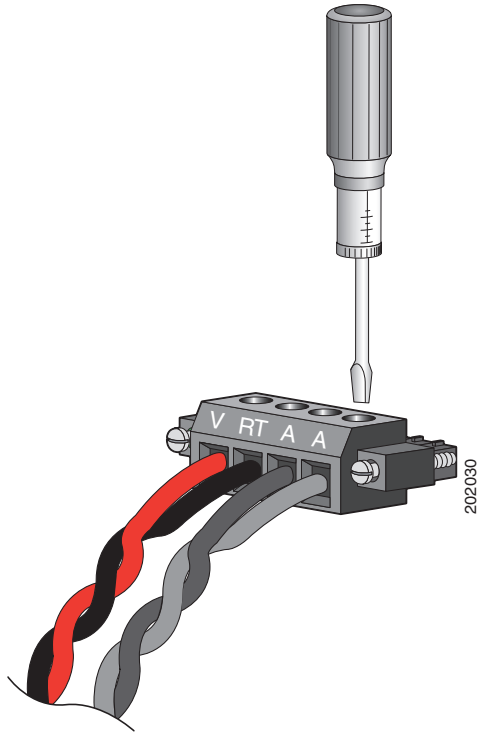

- Step 5** Repeat [Step 1](#) through [Step 4](#) to insert the input and output wires of an additional external alarm device into the second power and relay connector.
-

Figure 2-30 shows the completed wiring for two power supplies and two external alarm devices.

Figure 2-30 Completed Connections for Two External Alarm Devices on the Power and Relay Connector

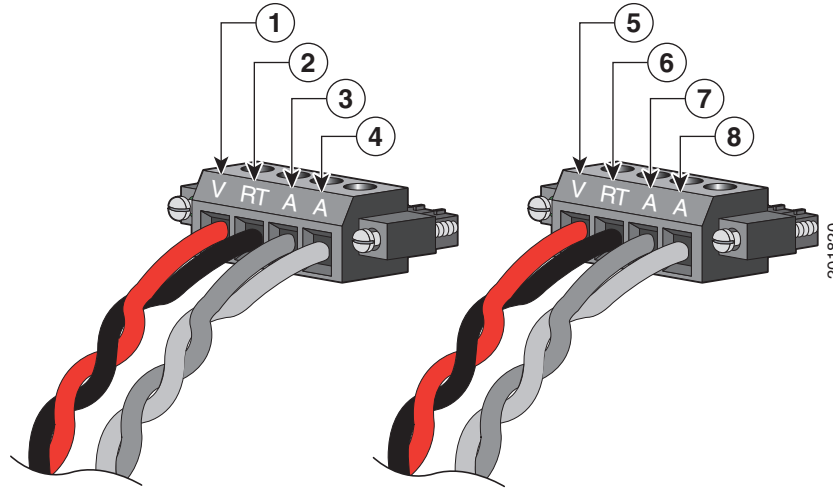

| | | | |
|----------|--|----------|--|
| 1 | Power source A positive connection | 5 | Power source B positive connection |
| 2 | Power source A return connection | 6 | Power source B return connection |
| 3 | External device 1, relay wire major alarm connection | 7 | External device 2, relay wire minor alarm connection |
| 4 | External device 1, relay wire major alarm connection | 8 | External device 2, relay wire minor alarm connection |

If your power source is -48 VDC, this table describes the wiring connections for Figure 2-30.

| | | | |
|----------|--|----------|--|
| 1 | Power source A return connection | 5 | Power source B return connection |
| 2 | Power source A -48 VDC connection | 6 | Power source B -48 VDC connection |
| 3 | External device 1, relay wire major alarm connection | 7 | External device 2, relay wire minor alarm connection |
| 4 | External device 1, relay wire major alarm connection | 8 | External device 2, relay wire minor alarm connection |

See the “Attach the Power and Relay Connector to the Switch” section on page 2-23 for instructions on how to connect the power and relay connector to the front panel.

Connecting Destination Ports

These section provide more information about connecting to the destination ports:

- [Connecting to 10/100 and 10/100/1000 Ports, page 2-40](#)
- [Installing and Removing SFP Transceivers, page 2-41](#)
- [Connecting to SFP Transceivers, page 2-44](#)
- [Connecting to a Dual-Purpose Port, page 2-45](#)
- [Connecting to 100BASE-FX Ports, page 2-47](#)
- [Connecting to a PoE Port, page 2-48](#)

Connecting to 10/100 and 10/100/1000 Ports

The switch 10/100/1000 ports automatically configure themselves to operate at the speed of attached devices. If the attached ports do not support autonegotiation, you can explicitly set the speed and duplex parameters. Connecting devices that do not autonegotiate or that have their speed and duplex parameters manually set can reduce performance or result in no linkage.

To maximize performance, choose one of these methods for configuring the Ethernet ports:

- Let the ports autonegotiate both speed and duplex.
- Set the port speed and duplex parameters on both ends of the connection.

**Caution**

To prevent electrostatic-discharge (ESD) damage, follow your normal board and component handling procedures.

To connect to 10BASE-T, 100BASE-TX or 1000BASE-T devices, follow these steps:

Step 1

When connecting to workstations, servers, routers, and Cisco IP Phones, connect a straight-through cable to an RJ-45 connector on the front panel. See [Figure 2-31](#).

When connecting to 1000BASE-T-compatible devices, to use a twisted four-pair, Category 5 or higher cable.

The auto-MDIX feature is enabled by default. For configuration information for this feature, see the switch software configuration guide or the switch command reference.

Figure 2-31 Connecting to an Ethernet Port

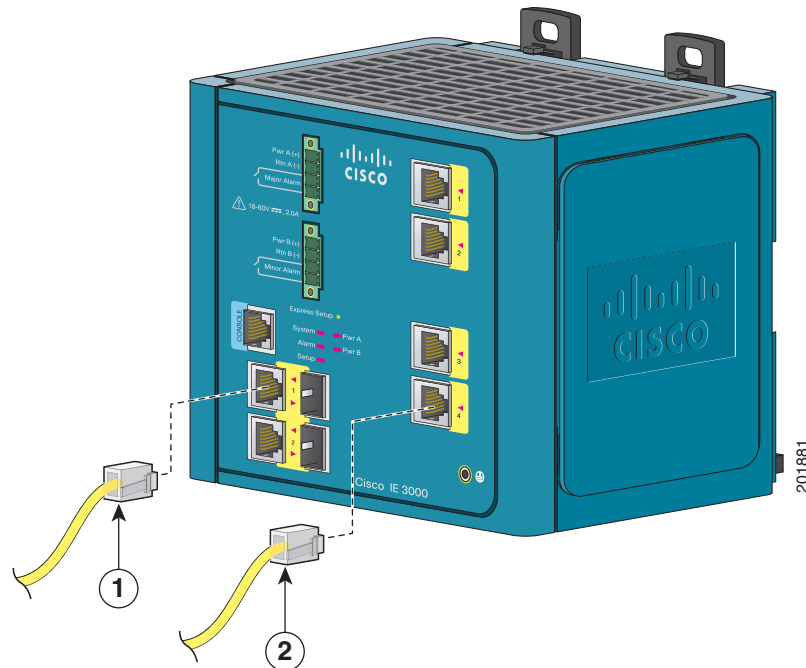

| | | | |
|----------|------------------|----------|--------------|
| 1 | 10/100/1000 port | 2 | 10/100 ports |
|----------|------------------|----------|--------------|

Step 2 Connect the other end of the cable to an RJ-45 connector on the other device. The port LED turns on when both the switch and the connected device have established link.

The port LED is amber while Spanning Tree Protocol (STP) discovers the topology and searches for loops. This can take up to 30 seconds, and then the port LED turns green. If the port LED does not turn on:

- The device at the other end might not be turned on.
- There might be a cable problem or a problem with the adapter installed in the attached device. See [Chapter 3, “Troubleshooting,”](#) for solutions to cabling problems.

Step 3 Reconfigure and reboot the connected device if necessary.

Step 4 Repeat Steps 1 through 3 to connect each device.

Installing and Removing SFP Transceivers

These sections describe how to install and remove SFP transceivers. SFP transceivers are inserted into SFP transceiver ports on the front of the switch or the Cisco IEM-3000-4SM or Cisco IEM-3000-8SM expansion modules. These field-replaceable transceivers provide the optical interfaces, send (TX) and receive (RX).

You can use any combination of rugged SFP transceiver. See the Cisco IE 3000 release notes for the list of supported SFP transceivers. SFP transceiver types must match on both ends of the network cable and the length of the network cable must not exceed the stipulated cable length for reliable communications. Supported cable lengths for the SFP transceivers are listed in [Table C-1 on page C-6](#).

**Caution**

When you use commercial SFP transceiver types such as CWDM and 1000BX-U/D in the IE-3000-4TC or IE-3000-8TC S switch SFP ports, reduce the maximum operating temperature by 59°F (15°C). The minimum operating temperature is 32°F (0°C). The IEM-3000-4SM or the IEM-3000-8SM expansion module SFP ports do not operate at 1Gbps.

For detailed instructions on installing, removing, and cabling the SFP transceivers, see the SFP module documentation.

Installing SFP Transceivers into Module Ports

**Note**

This procedure is applicable to SFP ports on either the switches or on the expansion modules.

Figure 2-32 shows an SFP transceiver that has a bale-clasp latch.

**Caution**

We strongly recommend that you do not install or remove the SFP transceiver with fiber-optic cables attached to it because of the potential damage to the cables, the cable connector, or the optical interfaces in the SFP module. Disconnect all cables before removing or installing an SFP transceiver.

Removing and installing an SFP transceiver can shorten its useful life. Do not remove and insert SFP transceiver more often than is absolutely necessary.

Figure 2-32 SFP Transceiver with a Bale-Clasp Latch

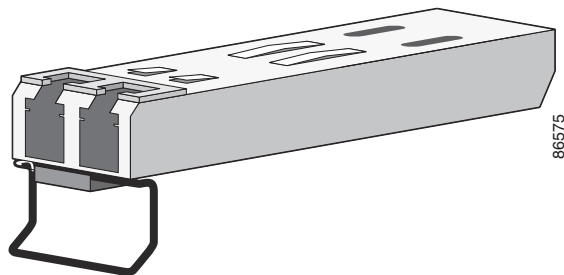

To insert an SFP transceiver into the module port, follow these steps:

- Step 1** Attach an ESD-preventive wrist strap to your wrist and to a grounded bare metal surface.
- Step 2** Find the send (TX) and receive (RX) markings that identify the correct side of the SFP transceiver.

**Note**

On some SFP transceivers, the send and receive (TX and RX) markings might be replaced by arrows that show the direction of the connection, either send or receive (TX or RX).

- Step 3** Position the SFP transceiver in front of the port opening.
- Step 4** Slide the SFP transceiver into the port until you feel the transceiver connector latch into place. See [Figure 2-33](#).

Figure 2-33 Installing an SFP Transceiver into an Module Port

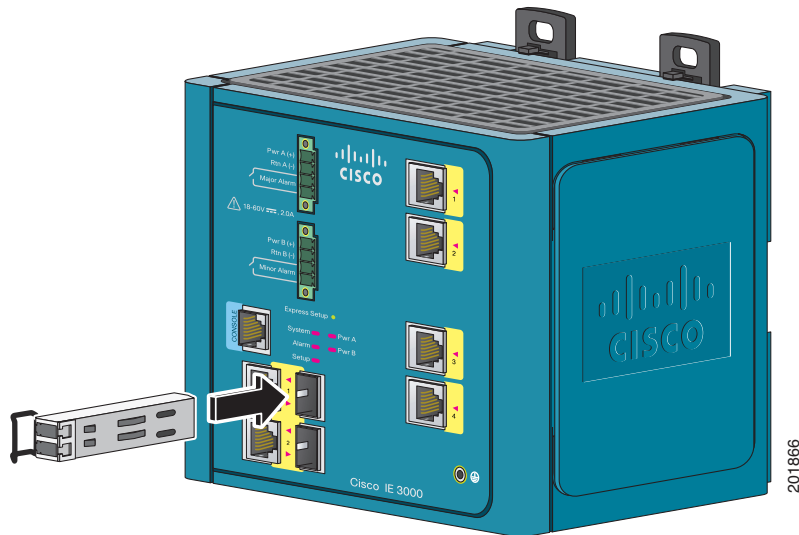

Caution

Do not remove the dust plugs from the SFP transceiver port or from the fiber-optic cable until you are ready to connect the cable. The plugs and caps protect the SFP transceiver optical connector and cables from contamination.

- Step 5** Using your thumb, press firmly on the SFP transceiver to ensure that the SFP is properly latched in the port.
- Step 6** When you are ready to install the network cable, remove the dust plugs from both the cable and the SFP transceiver and store them away for future use. Insert the LC network cable connector into the SFP transceiver.

Removing SFP Transceivers from Module Ports

To remove an SFP transceiver from a module port, follow these steps:

- Step 1** Attach an ESD-preventive wrist strap to your wrist and to a grounded bare metal surface.
- Step 2** Disconnect the network cable LC connector from the SFP transceiver.
- Step 3** Immediately insert a dust plug into the optical ports of the SFP transceiver and the network cable LC connector to keep the optical interfaces clean.
- Step 4** Rotate the bale-clasp downward and remove the SFP transceiver. See [Figure 2-34](#).
- If the module has a bale-clasp latch, pull the bale out and down to eject the module. If the bale-clasp latch is obstructed and you cannot use your index finger to open it, use a small, flat-blade screwdriver or other long, narrow instrument to open the bale-clasp latch.

Figure 2-34 Removing a Bale-Clasp Latch SFP Transceiver Using a Flat-Blade Screwdriver

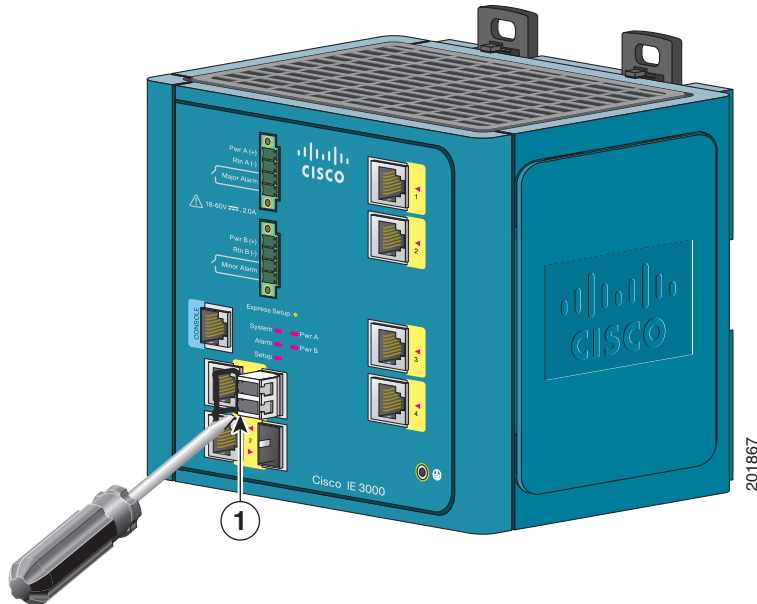

| | |
|----------|------------|
| 1 | Bale clasp |
|----------|------------|

- Step 5** Grasp the SFP transceiver between your thumb and index finger, and carefully remove it from the module port.
- Step 6** Place the removed SFP transceiver in an antistatic bag or other protective environment.

Connecting to SFP Transceivers

This section describes how to connect to a fiber-optic SFP port. To connect to an RJ-45 Gigabit Ethernet port instead of a fiber-optic port, see the [“Connecting to a Dual-Purpose Port”](#) section on page 2-45.

For instructions on how to install or remove an SFP transceiver, see the [“Installing and Removing SFP Transceivers”](#) section on page 2-41.

Follow these steps to connect a fiber-optic cable to an SFP transceiver:



Warning

Class 1 laser product. Statement 1008



Caution

Do not remove the rubber plugs from the SFP transceiver port or the rubber caps from the fiber-optic cable until you are ready to connect the cable. The plugs and caps protect the SFP transceiver optical bores and cables from contamination.

Before connecting to the SFP module, be sure that you understand the port and cabling stipulations in the [“Preparing for Installation”](#) section on page 2-1. See [Appendix C, “Cable and Connectors,”](#) for information about the LC on the SFP transceiver.

- Step 1** Remove the rubber plugs from the transceiver and fiber-optic cable, and store them for future use.
- Step 2** Insert the fiber-optic cable LC connector into the SFP transceiver. See [Figure 2-35](#).

Figure 2-35 Connecting a Fiber-Optic LC Connector into an SFP Transceiver

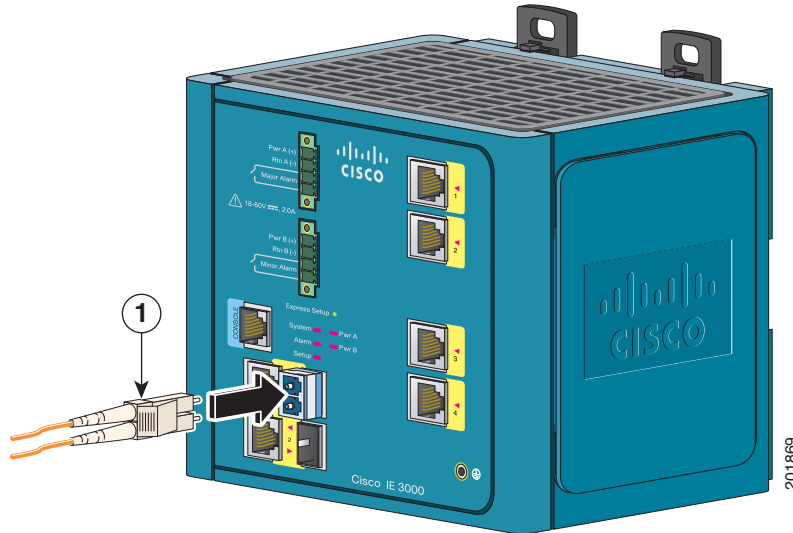

1 LC connector

- Step 3** Insert the other cable end into a fiber-optic receptacle on a target device.
- Step 4** Observe the port status LED.
- The LED turns green when the switch and the target device have an established link.
- The LED turns amber while the STP discovers the network topology and searches for loops. This process takes about 30 seconds, and then the port LED turns green.
- If the LED is off, the target device might not be turned on, there might be a cable problem, or there might be a problem with the adapter installed in the target device. See [Chapter 3, “Troubleshooting,”](#) for solutions to cabling problems.
- Step 5** If necessary, reconfigure and restart the switch or the target device.

Connecting to a Dual-Purpose Port

The dual-purpose port is a single port with two interfaces, one for an RJ-45 cable and another for an SFP module. Only one interface can be active at a time. If both interfaces are connected, the SFP module has priority. For more information about dual-purpose ports, see the [“Dual-Purpose Ports”](#) section on [page 1-8](#).



Warning

Class 1 laser product. Statement 1008

**Caution**

Do not remove the rubber plugs from the SFP transceiver port or the rubber caps from the fiber-optic cable until you are ready to connect the cable. The plugs and caps protect the SFP transceiver optical bores and cables from contamination.

Before connecting to the SFP module, be sure that you understand the port and cabling stipulations in the “[Preparing for Installation](#)” section on page 2-1. See [Appendix C, “Cable and Connectors,”](#) for information about the LC on the SFP module.

To connect to a dual-purpose port, follow these steps:

- Step 1** Connect an RJ-45 connector to the 10/100/1000 port, or install an SFP transceiver into the module port, and connect a cable to the SFP transceiver. See [Figure 2-36](#).

For more information about RJ-45 connections, SFP transceivers, and optical connections, see the “[Connecting to 10/100 and 10/100/1000 Ports](#)” section on page 2-40, the “[Installing and Removing SFP Transceivers](#)” section on page 2-41, and the “[Connecting to SFP Transceivers](#)” section on page 2-44.

Figure 2-36 Connecting to a Dual-Purpose Port

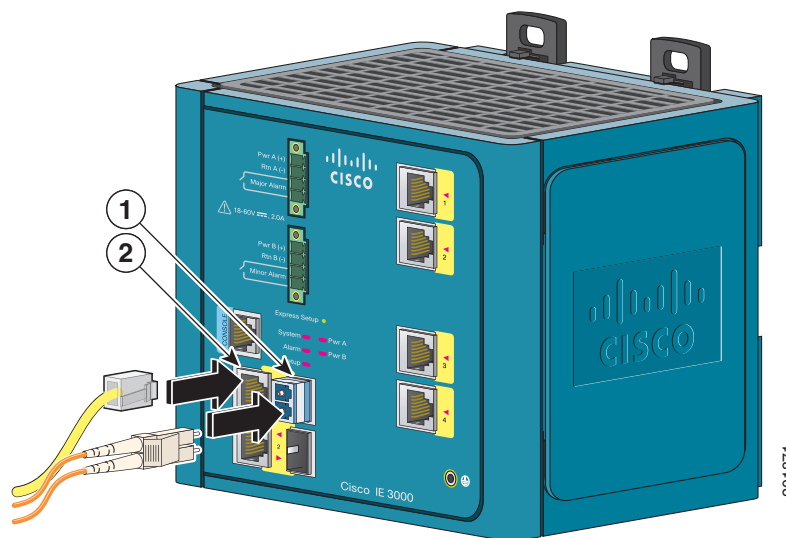

| | | | |
|----------|--------------|----------|-----------------|
| 1 | LC connector | 2 | RJ-45 connector |
|----------|--------------|----------|-----------------|

- Step 2** Connect the other end of the cable to the other device.

By default, the switch detects whether an RJ-45 connector or SFP transceiver is connected to a dual-purpose port and configures the port accordingly. You can change this setting and configure the port to recognize only an RJ-45 connector or only an SFP module by using the **media type** interface configuration command. For more information, see the switch command reference.

Connecting to 100BASE-FX Ports

Follow these steps to connect a fiber-optic cable to an Cisco IEM-3000-8FM expansion module:

Warning

Class 1 laser product. Statement 1008



Caution

Do not remove the rubber plugs from the SFF module port or the rubber caps from the fiber-optic cable until you are ready to connect the cable. The plugs and caps protect the SFF module ports and cables from contamination.

Before connecting to the SFF module port, be sure that you understand the port and cabling stipulations in the [“Preparing for Installation” section on page 2-1](#). See the [“Cable and Adapter Specifications” section on page C-5](#) for information about the LC connector on the SFF module.

- Step 1** Remove the rubber plugs from the module port and fiber-optic cable, and store them for future use.
- Step 2** Insert one end of the fiber-optic cable into the SFP module port. See [Figure 2-37](#).

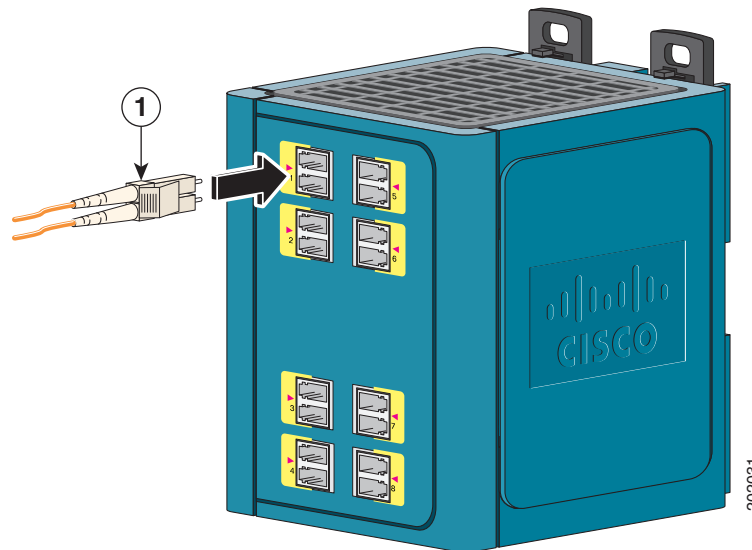
Figure 2-37 Connecting to a Fiber-Optic SFP Module Port



| | |
|----------|--------------|
| 1 | LC connector |
|----------|--------------|

- Step 3** Insert the other cable end into a fiber-optic receptacle on a target device.
- Step 4** Observe the port status LED.

The LED turns green when the switch and the target device have an established link.

The LED turns amber while the STP discovers the network topology and searches for loops. This process takes about 30 seconds, and then the port LED turns green.

If an LED is off, the target device might not be turned on, there might be a cable problem, or there might be a problem with the adapter installed in the target device. See [Chapter 3, “Troubleshooting,”](#) for solutions to cabling problems.

Step 5 If necessary, reconfigure and restart the switch or target device.

Connecting to a PoE Port

The expansion module PoE ports support either the IEEE 802.3af standard (PoE), which provides up to 15.4 W of power per port (4 ports total), or the IEEE 802.3at standard (PoE+), which provides up to 30 W of power per port. To allow 4 PoE+ ports, the following command line is required when using over 65 W power input to the expansion module:

```
[power inline wattage <mod> max <4-130> watts]
```

Connecting the Switch to the Power Converter

The Cisco IE 3000 switch can be used with an optional AC/DC power converter (PWR-IE3000-AC). These sections describe the steps required to connect the switch to a power converter:

- [Attaching the Power Converter to the Switch, page 2-49](#)
- [Installing the Power Converter on a DIN Rail, Wall, or Rack Adapter, page 2-50](#)
- [Connecting the DC Power Clip, page 2-50](#)
- [Connecting the Power Converter to an AC Power Source, page 2-51](#)
- [Connecting the Power Converter to a DC Power Source, page 2-54](#)
- [Applying Power to the Power Converter, page 2-56](#)

Attaching the Power Converter to the Switch

To connect the power converter to the switch, follow these steps:

- Step 1** Remove the left side panel of the switch by firmly grasping both sides of it in the middle and pulling it outward. If necessary, use a screwdriver to open the side panel. See [Figure 2-38](#).

Figure 2-38 Opening the Left Side Panel of the Switch

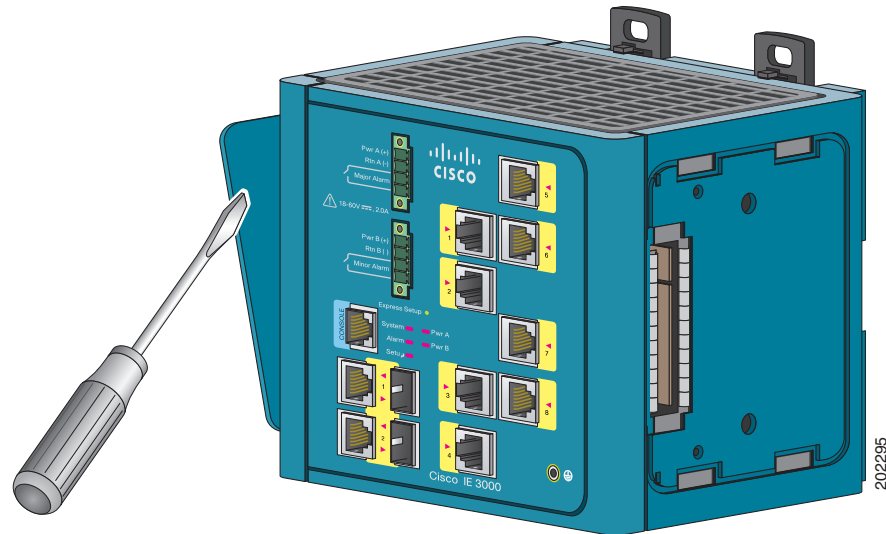

- Step 2** Push the upper modules latches (at the top of the switch and the power converter) up and the lower module latches (at the bottom of the switch and the power converter) down. See [Figure 2-39](#).

Figure 2-39 Pushing the Module Latches Up and Positioning the Hardware

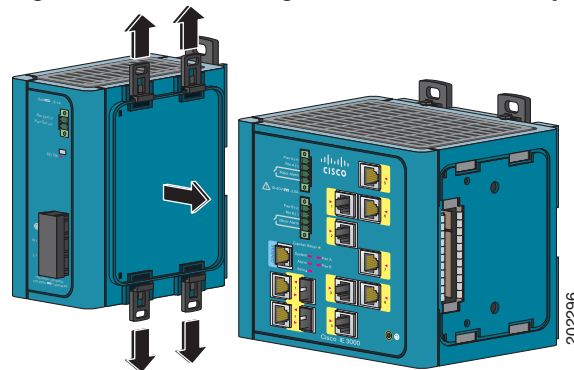

- Step 3** Put the two modules together so that the power module fits in the switch recess.
- Step 4** Push the upper module latches down and the lower module latches up to secure the power converter to the switch. See [Figure 2-40](#).

Figure 2-40 Pushing the Latches In

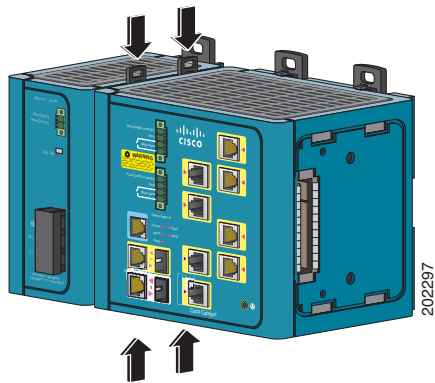

Installing the Power Converter on a DIN Rail, Wall, or Rack Adapter

You install the power converter on a DIN rail, wall, or rack as you would a switch module. You should first attach the power converter to the switch and then install the entire switch assembly on the DIN rail, wall, or rack adapter. For more information, see the [“Attaching the Power Converter to the Switch”](#) section on page 2-49, the [“Installing the Switch on a DIN Rail”](#) section on page 2-27, the [“Installing the Switch on the Wall”](#) section on page 2-31, or the [“Installing the Switch in a Rack”](#) section on page 2-33.



Warning

This equipment is supplied as “open type” equipment. It must be mounted within an enclosure that is suitably designed for those specific environmental conditions that will be present and appropriately designed to prevent personal injury resulting from accessibility to live parts. The interior of the enclosure must be accessible only by the use of a tool.

The enclosure must meet IP 54 or NEMA type 4 minimum enclosure rating standards. Statement 1063



Caution

To prevent the switch assembly from overheating, there must be a minimum of 3 inches (76.19 mm) between any other device and the top, bottom, or sides of the switch assembly.

Connecting the DC Power Clip

The DC power clip is a prewired cable that connects DC power from the power converter to the switch module. Because the power clip uses the Pwr A connector, you cannot use the alarm connections on that connector.

Follow these steps to connect DC power from the power converter to the switch module.

- Step 1** Locate the DC power clip in the power converter accessory kit.
- Step 2** Position the power clip so that the two-pin connector is over the power converter and the four-pin connector is over the switch Pwr A connector, and then slide the power clip into these two connectors. See [Figure 2-41](#).

Figure 2-41 Connecting Wires to the Power Converter DC Output Terminal Block

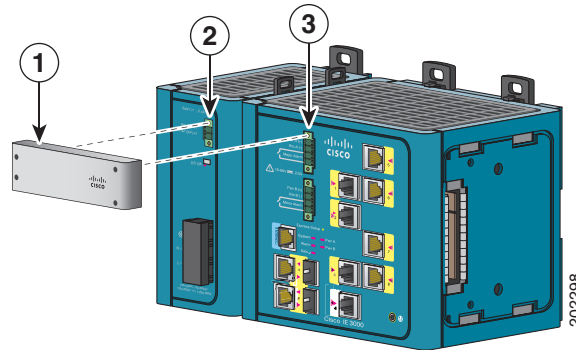

| | | | |
|----------|--|----------|----------------------------------|
| 1 | DC power clip | 3 | Four-pin connector on the switch |
| 2 | Two-pin connector on the power convertor | | |

- Step 3** Use a ratcheting torque flathead screwdriver to tighten the captive screw to 2.2 in-lb (0.25 Nm).



Caution

Do not over-torque the power and relay connector captive screws. The torque should not exceed 2.2 in-lb (0.25 Nm).

Connecting the Power Converter to an AC Power Source

These sections describe the steps required to connect the power converter to an AC power source:

- [Preparing the AC Power Cord, page 2-51](#)
- [Connecting the AC Power Cord to the Power Converter, page 2-52](#)

Preparing the AC Power Cord

To connect the power converter to an AC power source, you need an AC power cord. Power cord connector types and standards vary by country. Power-cord wiring color codes also vary by country. You must have a qualified electrician select, prepare, and install the appropriate power cord to the power supply.

**Note**

Use copper conductors only, rated at a minimum temperature of 167°F (75°C).

Connecting the AC Power Cord to the Power Converter

The following instructions are provided for a qualified electrician to attach the AC power cord to the power supply.

**Caution**

AC power sources must be dedicated AC branch circuits. Each branch circuit must be protected by a dedicated two-pole circuit breaker.

**Caution**

Do not insert the power cord into the AC outlet until the process of wiring the line, neutral, and ground connections has been completed.

To connect the AC power cord to the power converter, follow these steps:

- Step 1** Remove the plastic cover from the input power terminals and set it aside. See [Figure 2-42](#).

Figure 2-42 AC/DC Power Input Terminal Block

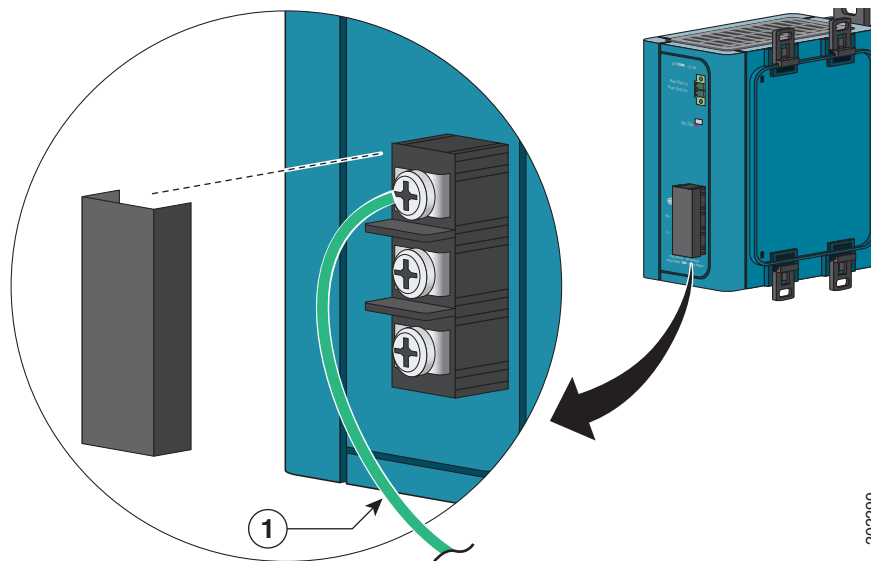

| | |
|----------|-------------|
| 1 | Ground wire |
|----------|-------------|

- Step 2** Insert the exposed ground wire lead into the power converter ground wire connection. Ensure that only wire *with insulation* extends from the connector. See [Figure 2-43](#).

Figure 2-43 Connecting AC Power to the Power Converter

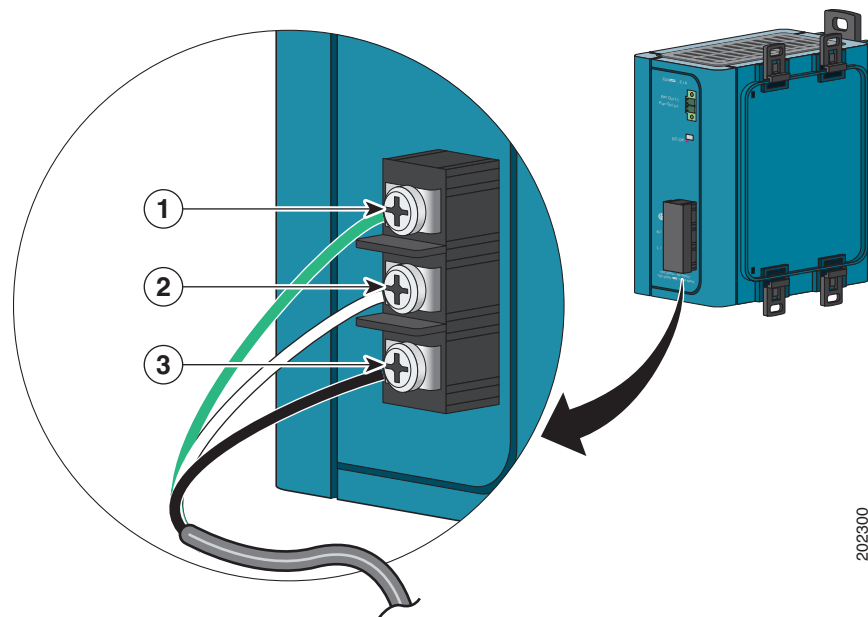

202300

| | | | |
|----------|------------|----------|---------|
| 1 | Ground | 3 | AC line |
| 2 | AC neutral | | |

Step 3 Tighten the ground wire terminal block screw.



Note The torque should not exceed 2.2 in-lb (0.25 Nm).

Step 4 Insert the line and neutral wire leads into the terminal block line and neutral connections. See [Figure 2-43](#). Make sure that you cannot see any wire lead. Ensure that only wire *with insulation* extends from the connectors.

Step 5 Tighten the line and neutral terminal block screws.



Note The torque should not exceed 2.2 in-lb (0.25 Nm).

Step 6 Replace the plastic cover over the terminal block.

Step 7 Connect the other end of the AC power cord to the AC outlet.

Connecting the Power Converter to a DC Power Source

You can also connect the power converter to a DC power source. The power converter adapts the power source voltage to the 24 VDC that the switch requires.

Follow these steps to connect the power converter to a DC power source.



Note Use copper conductors only, rated at a minimum temperature of 167°F (75°C).

- Step 1** Measure a single length of stranded copper wire long enough to connect the power converter to the earth ground. The wire color might differ depending on the country that you are using it in.
- For connections from the power converter to earth ground, use shielded 18-AWG stranded copper wire, such as Belden part number 9912 or the equivalent.
- Step 2** Measure a length of twisted-pair copper wire long enough to connect the power converter to the DC power source.
- For DC connections from the power converter to the DC source, use 18-AWG twisted-pair copper wire, such as Belden part number 9344 or the equivalent.
- Step 3** Using a 18-gauge wire-stripping tool, strip the ground wire and both ends of the twisted pair wires to 0.25 inch (6.3 mm) ± 0.02 inch (0.5 mm). Do not strip more than 0.27 inch (6.8 mm) of insulation from the wires. Stripping more than the recommended amount of wire can leave exposed wire from the power and relay connector after installation. See [Figure 2-9](#).
- Step 4** Connect one end of the stranded copper wire to a grounded bare metal surface, such as a ground bus, a grounded DIN rail, or a grounded bare rack.
- Step 5** Insert the other end of the exposed ground wire lead into the earth-ground wire connection on the power converter terminal block. Only wire *with insulation* should extend from the connection. See [Figure 2-44](#).
- Step 6** Tighten the earth-ground wire connection terminal block screw.



Note The torque should not exceed 2.2 in-lb (0.25 Nm).

Figure 2-44 AC/DC Power Input Terminal Block Wire Connections to a DC Source

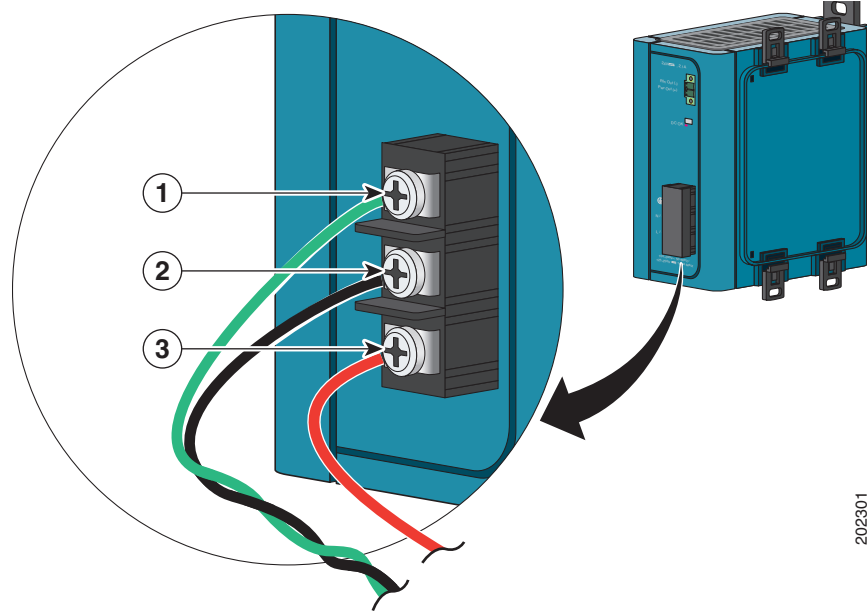

| | | | |
|---|---------------------------------------|---|------------------------|
| 1 | Earth ground wire connection | 3 | Positive DC connection |
| 2 | Return wire connection (to DC return) | | |

**Warning**

An exposed wire lead from a DC-input power source can conduct harmful levels of electricity. Be sure that no exposed portion of the DC-input power source wire extends from the power and relay connector. Statement 122

Step 7 Insert the twisted-pair wire leads into the terminal block line and neutral connections. Insert the wire (labeled number 1 in Figure 2-44) lead into the neutral wire connection and the wire (labeled number 2 in Figure 2-44) lead into the line wire connection. Ensure that only wire *with insulation* extends from the connectors. See Figure 2-44.

Step 8 Tighten the line and neutral terminal block screws.

**Note**

The torque should not exceed 10 in-lb.

Step 9 Connect the red wire to the positive pole of the DC power source, and connect the black wire to the return pole. Ensure that each pole has a current-limiting-type fuse rated to at least 600 VAC/DC (such as the KLKD Midget fuse).

Applying Power to the Power Converter

Move the circuit breaker for the AC outlet or the DC control circuit to the *on* position.

The LED on the power converter front panel is green when the unit is operating normally. The LED is off when the unit is not powered or is not operating normally. After the power is connected, the switch automatically begins the power-on self- test (POST), a series of tests that verifies that the switch functions properly. For instructions on how to interpret POST results, see the [“Verify POST Results” section on page 2-25](#).

Connecting the Switch to the AC-Input Power Supply

The Cisco IE 3000 switch can be used with an optional AC-input power supply (PWR-IE50W-AC or PWR-IE50W-AC-IEC).

These sections describe the steps required to connect the switch to the AC-input power supply:

- [Attaching the Power Supply to the Switch, page 2-56](#)
- [Installing the AC-input Power Supply on a DIN Rail, Wall, or Rack Adapter, page 2-56](#)
- [Connecting the DC Power Clip, page 2-57](#)
- [Connecting the AC-Input Power Supply to an AC Power Source, page 2-57](#)

Attaching the Power Supply to the Switch

Follow these steps to connect the AC-input power supply to the switch:

-
- | | |
|---------------|---|
| Step 1 | Remove the left side panel of the switch by firmly grasping both sides of it in the middle and pulling it outward. If necessary, use a screwdriver to open the side panel. See Figure 2-38 for an illustration of how to remove the switch side panel. |
| Step 2 | Push the upper module latches (at the top of the switch and the AC-input power supply) up and the lower module latches (at the bottom of the switch and the AC-input power supply) down. See Figure 2-39 for an illustration showing the latches operation. |
| Step 3 | Put the two modules together so that the AC-input power supply fits in the switch recess. |
| Step 4 | Push the upper module latches down and the lower module latches up to secure the AC-input power supply to the switch. |
-

Installing the AC-input Power Supply on a DIN Rail, Wall, or Rack Adapter

You install the AC-input power supply on a DIN rail, wall, or rack as you would a switch module. You should first attach the AC-input power supply to the switch and then install the entire switch assembly on the DIN rail, wall, or rack adapter. For more information, see the [“Attaching the Power Supply to the Switch” section on page 2-56](#), the [“Installing the Switch on a DIN Rail” section on page 2-27](#), the [“Installing the Switch on the Wall” section on page 2-31](#), or the [“Installing the Switch in a Rack” section on page 2-33](#).

**Warning**

This equipment is supplied as “open type” equipment. It must be mounted within an enclosure that is suitably designed for those specific environmental conditions that will be present and appropriately designed to prevent personal injury resulting from accessibility to live parts. The interior of the enclosure must be accessible only by the use of a tool.

The enclosure must meet IP 54 or NEMA type 4 minimum enclosure rating standards. Statement 1063

**Caution**

To prevent the switch assemble from overheating, there must be a minimum of 3 inches (76.19 mm) between any other device and the top, bottom, or sides of the switch assembly.

Connecting the DC Power Clip

The DC power clip (PWR-IE3000-CLP=) is a prewired cable that connects DC power from the power converter to the switch module. Because the power clip uses the Pwr A connector, you cannot use the alarm connections on that connector.

Follow these steps to connect DC power from the AC-input power supply to the switch module.

- Step 1** Locate the DC power clip in the AC-input power supply accessory kit.
- Step 2** Position the power clip so that the two-pin connector is over the power converter and the four-pin connector is over the switch Pwr A connector, and then slide the power clip into these two connectors.
- Step 3** Use a ratcheting torque flathead screwdriver to tighten the captive screw to 2.2 in-lb (0.25 Nm).

**Caution**

Do not over-torque the power and relay connector captive screws. The torque should not exceed 2.2 in-lb (0.25 Nm).

Connecting the AC-Input Power Supply to an AC Power Source

The following sections provide the steps required to connect the AC-input power supply to source AC. For the AC-input power supply equipped with a source AC terminal block (PWR-50W-AC), you need to have a qualified electrician select, prepare, and install a suitable AC power cord to the AC-input power supply.

For the AC-input power supply equipped with an IEC C14 appliance connector (PWR-50W-AC-IEC), you need to obtain an AC power cord with a suitable AC plug for the locality on one end and a C13 appliance connector on the other end. To connect source AC to the power supply, plug the AC power cord appliance connector into the power supply AC in connector. Plug the other end of the AC power cord into a dedicated source AC outlet.

Connecting the AC Power Cord to the Power Supply



This procedure is provided for a qualified electrician to follow when installing an AC power cord to the AC in terminal block on the AC-input power supply. To connect the AC power cord wires to the power supply terminal block, follow these steps:

Caution

AC power sources must be on dedicated AC branch circuits. Each branch circuit must be protected by a dedicated two-pole circuit breaker.

Caution

Do not insert the power cord plug into the AC outlet until you have completed wiring the line, neutral, and ground connections.

-
- Step 1** Remove the plastic cover from the input power terminals and set it aside.
- Step 2** Loosen the three Phillips-head terminal screws on the terminal block.
- Step 3** Insert the exposed ground wire lead into the power supply ground wire connection on the terminal block. Ensure that only wire *with insulation* extends from the connector. Connecting AC Power to the Power Converter
- Step 4** Tighten the ground wire terminal block screw.
-
-  **Note** The torque should not exceed 2.2 in-lb (0.25 Nm).
-
- Step 5** Insert the line and neutral wire leads into the terminal block line and neutral connections. Make sure that you cannot see any wire lead. Ensure that only wire *with insulation* extends from the connectors.
- Step 6** Tighten the line and neutral terminal block screws.
-
-  **Note** The torque should not exceed 2.2 in-lb (0.25 Nm).
-
- Step 7** Replace the plastic cover over the terminal block.
- Step 8** Connect the plug end of the AC power cord into the source AC outlet.
-

Where to Go Next

If the default configuration is satisfactory, the switch does not need further configuration. You can use any of these management options to change the default configuration:

- Start the device manager, which is in the switch memory, to manage individual and standalone switches. This is an easy-to-use web interface that offers quick configuration and monitoring. You can access the device manager from anywhere in your network through a web browser. For more information, see the switch getting started guide and the device manager online help.
- Start the Cisco Network Assistant application, which is described in the *Getting Started with Cisco Network Assistant* guide. Through this GUI, you can configure and monitor a switch cluster or an individual switch.

- Use the CLI to configure the switch as an individual switch from the console. See the switch command reference on Cisco.com for information about using the CLI.
- Start an SNMP application such as the CiscoView application.

Start the Common Industrial Protocol (CIP) management tool. You can manage an entire industrial automation system with the CIP-based tools.

■ Where to Go Next



Troubleshooting

This chapter provides these topics for troubleshooting problems:

- [Diagnosing Problems, page 3-1](#)
- [How to Clear the Switch IP Address and Configuration, page 3-5](#)
- [How to Recover Passwords, page 3-5](#)
- [Finding the Switch Serial Number, page 3-6](#)

Diagnosing Problems

The LEDs on the front panel provide troubleshooting information about the switch. They show power-on self-test (POST) failures, port-connectivity problems, and overall switch performance. You can also get statistics from the browser interface, the command-line interface (CLI), the Cisco Intelligence Engine 2100 (IE2100) Series Configuration Registrar, or a Simple Network Management Protocol (SNMP) workstation. See the switch software configuration guide, the switch command reference, or the documentation that came with your IE2100 or SNMP application for details.

Verify Switch POST Results

As the switch powers on, it begins the POST, a series of tests that runs automatically to ensure that the switch functions properly. It might take several minutes for the switch to complete POST.

POST starts with LED tests that cycles once through the System, Alarm, Setup, Pwr A, and Pwr B LEDs. While POST proceeds, the System LED blinks green, and all the other LEDs remain off. If POST completes successfully, the System LED changes to solid green, and the other LEDs display their normal operating status. If the switch fails POST, the System LED turns red.



Note

POST failures are usually fatal. Contact your Cisco technical support representative if your switch does not pass POST.

If you have a terminal connected to the console port, you can also view POST status and test results on the terminal. If the terminal displays garbled characters, you might need to reset the terminal-emulation software to 9600 bits per second. For more information about viewing results on a terminal, see the [“Verify POST Results” section on page 2-25](#).

**Warning**

If you connect or disconnect the console cable with power applied to the switch or any device on the network, an electrical arc can occur. This could cause an explosion in hazardous location installations. Be sure that power is removed or the area is nonhazardous before proceeding.

To verify switch operation, perform POST on the switch in a nonhazardous location before installation. Statement 1065

Verify Switch LEDs

If you have physical access to the switch, look at the port LEDs for information about the switch. See the “LEDs” section on page 1-11 for a description of the LED colors and their meanings.

Verify Switch Connections

Review this section when troubleshooting switch connection problems.

Bad or Damaged Cable

Always make sure that the cable does not have marginal damage or failure. A cable might be connect at the physical layer, but it could corrupt packets as a result of subtle damage to the wiring or connectors. If the port has many packet errors or the port constantly flaps (loses and regains link):

- Exchange the copper or fiber-optic cable with a known, good cable.
- Look for broken, bent, or missing pins on cable connectors.
- Rule out any bad patch panel connections or media convertors between the source and destination. If possible, bypass the patch panel, or eliminate faulty media convertors (fiber-optic-to-copper).
- Try the cable in another port or interface, if possible, to see if the problem follows the cable.

Ethernet and Fiber Cables

Make sure that you have the correct cable type for the connection:

- Ethernet, use Category 3 copper cable for 10 Mb/s UTP connections
Use either Category 5, Category 5e, or Category 6 UTP for 10/100 or 10/100/1000 Mb/s connections.
- Fiber-optic connectors

Verify that you have the correct cable for the distance and the port type. Make sure that the connected device ports both match and use the same type encoding, optical frequency, and fiber type. For more information about cabling, see the “Cable and Adapter Specifications” section on page C-5.

- Copper connections

Determine if a crossover cable was used when a straight-through was required or the reverse. Enable auto-MDIX on the switch, or replace the cable. See the “Cable and Adapter Specifications” section on page C-5 for recommended Ethernet cables.

Link Status

Verify that both sides have link. A single broken wire or one shutdown port can cause one side to show link, but the other side does not have link.

A link LED does not guarantee that the cable is fully functional. The cable might have encountered physical stress that causes it to function at a marginal level. If the link light for the port does not come on:

- Connect the cable from the switch to a known good device.
- Make sure that both ends of the cable are connected to the correct ports.
- Verify that both devices have power.
- Verify that you are using the correct cable type. See the “[Cable and Adapter Specifications](#)” section on page C-5 for more information.
- Rule out loose connections. Sometimes a cable appears to be seated, but is not. Disconnect the cable, and then reconnect it.

Transceiver Issues

Use only Cisco SFP modules on the switch. Each Cisco module has an internal serial EEPROM that is encoded with security information. This encoding provides a way for Cisco to identify and validate that the module meets the requirements for the switch. Check these items:

- Bad or wrong SFP module. Exchange the suspect module with a known good module. Verify that the module is supported on this platform. (The switch release notes on Cisco.com list the SFP modules that the switch supports.)
- Use the **show interfaces** privileged EXEC command to verify the port or module error-disabled, disabled, or shutdown status. Re-enable the port if needed.
- Make sure that all fiber connections are properly cleaned and securely connected.

Port and Interface Settings

A cause of port connectivity failure can be a disabled port. Verify that the port or interface is not disabled or powered down for some reason. If a port or interface is manually shut down on one side of the link or the other side, the link does not come up until you re-enable the port. Use the **show interfaces** privileged EXEC command to verify the port or interface error-disabled, disabled, or shutdown status on both sides of the connection. If needed, re-enable the port or the interface.

Ping End Device

Test the end device by pinging from the directly connected switch first, and then work your way back port by port, interface by interface, trunk by trunk, until you find the source of the connectivity issue. Make sure that each switch can see the end device MAC address in its content-addressable memory (CAM) table.

Spanning Tree Loops

Spanning Tree Protocol (STP) loops can cause serious performance issues that look like port or interface problems. In this situation, the switch bandwidth is used over and over again by the same frames, leaving little room for legitimate traffic.

Loops can be caused by a unidirectional link. A unidirectional link occurs whenever the traffic sent by the switch is received by its neighbor, but the traffic from the neighbor is not received by the switch. A broken fiber-optic cable, other cabling, or a port issue could cause this one-way communication.

You can enable UniDirectional Link Detection (UDLD) on the switch to help identify difficult-to-find unidirectional link problems. UDLD supports two modes of operation: normal (the default) and aggressive. In normal mode, UDLD detects unidirectional links due to misconnected interfaces on fiber-optic connections. In aggressive mode, UDLD also detects unidirectional links due to one-way traffic on fiber-optic and twisted-pair links and due to misconnected interfaces on fiber-optic links. For information about enabling UDLD on the switch, see the “Understanding UDLD” section in the “Configuring UDLD” chapter of the software configuration guide for this release.

Verify Switch Performance

Review this section when troubleshooting switch performance problems.

Speed, Duplex, and Autonegotiation

If the port statistics show a large amount of alignment errors, frame check sequence (FCS), or late-collisions errors, this might indicate a speed or duplex mismatch.

A common issue with speed and duplex is when the duplex settings are mismatched between two switches, between a switch and a router, or between the switch and a workstation or server. This can happen when manually setting the speed and duplex or from autonegotiation issues between the two devices. A mismatch occurs under these circumstances:

- A manually set speed or duplex parameter is different from the manually set speed or duplex parameter on the connected port.
- A port is set to autonegotiate, and the connected port is set to full duplex with no autonegotiation.

To maximize switch performance and ensure a link, follow one of these guidelines when changing the settings for duplex and speed:

- Let both ports autonegotiate both speed and duplex.
- Manually set the speed and duplex parameters for the ports on both ends of the connection.
- If a remote device does not autonegotiate, configure the duplex settings on the two ports to match. The speed parameter can adjust itself even if the connected port does not autonegotiate.

Autonegotiation and NIC

Problems sometimes occur between the switch and third-party network interface cards (NICs). By default, the switch ports and interfaces are set to autonegotiate. It is common for devices like laptops or other devices to be set to autonegotiate as well, yet sometimes autonegotiation issues occur.

To troubleshoot autonegotiation problems, try manually setting both sides of the connection. If this does not solve the problem, there could be a problem with the firmware or software on your NIC. You can resolve this by upgrading the NIC driver to the latest version available from the manufacture.

Cabling Distance

If the port statistics show excessive FCS, late-collision, or alignment errors, verify that the cable distance from the switch to the connected device meets the recommended guidelines. See the “[Cable and Connectors](#)” section on page C-1 for cabling guidelines.

How to Clear the Switch IP Address and Configuration

Follow these steps to return your switch to the factory default settings. These are reasons why you might want to reset the switch:

- You installed the switch in your network and cannot connect to it because you assigned the wrong IP address.
- You want to clear all configurations from the switch and assign a new IP address.
- You want to reset the password on the switch.

**Caution**

Resetting the switch deletes the configuration and reboots the switch.

To reset the password on the switch:

1. Power off the switch.
2. Power on the switch, and at the same time, press and hold down the Express Setup button until all the system LEDs turn red.
3. Release the Express Setup button, and the switch continues to boot.

After the switch restarts, continue to run Express Setup.

The switch now behaves like an unconfigured switch. You can configure the switch by using Express Setup as described in the getting started guide that is included with the switch. You can also configure the switch by using the CLI setup procedure described in [Appendix D, “Configuring the Switch with the CLI-Based Setup Program.”](#)

How to Recover Passwords

Password recovery is a feature that a system administrator can enable or disable. If password recovery is disabled, the only way to recover from a lost or forgotten password is to clear the switch configuration entirely. For this procedure, see the “[How to Clear the Switch IP Address and Configuration](#)” section on page 3-5.

The switch software configuration guide provides details about enabling and disabling the password recovery feature and the procedure for recovering passwords.

Finding the Switch Serial Number

If you contact Cisco Technical Assistance, you need to know the serial number of your switch. See [Figure 3-1](#) and [Figure 3-2](#) to find the serial number on your switch or module. See [Figure 3-3](#) to find the serial number on your power converter. You can also use the **show version** privileged EXEC command to get the switch serial number.

Figure 3-1 Serial Number Location for the Cisco IE-3000-4TC and the Cisco IE-3000-8TC Switch

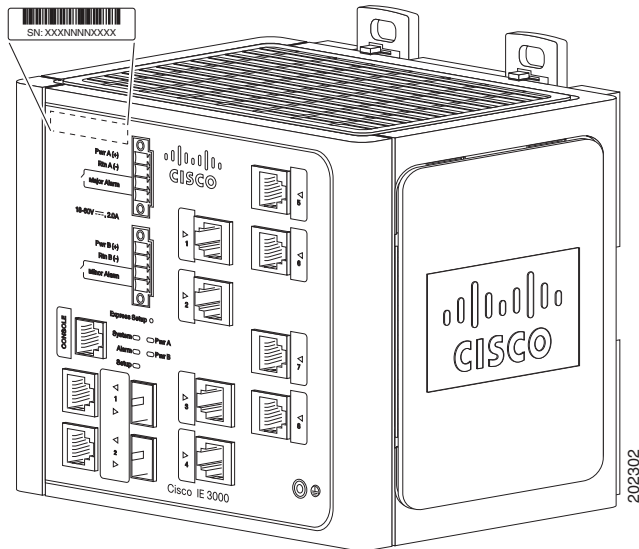

Figure 3-2 Serial Number Location for the Cisco IEM-3000-8TM and the Cisco IEM-3000-8FM Module

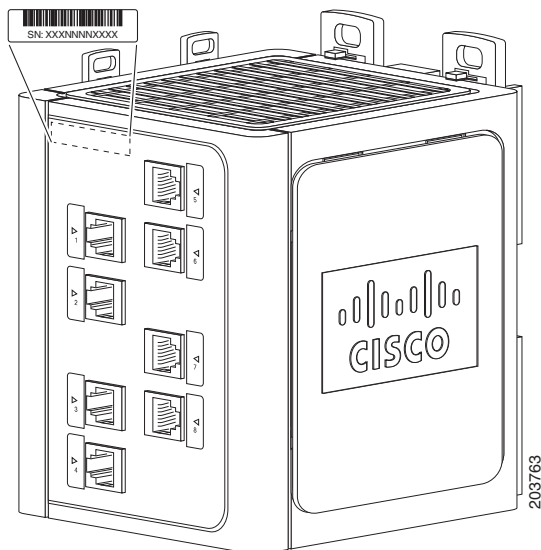
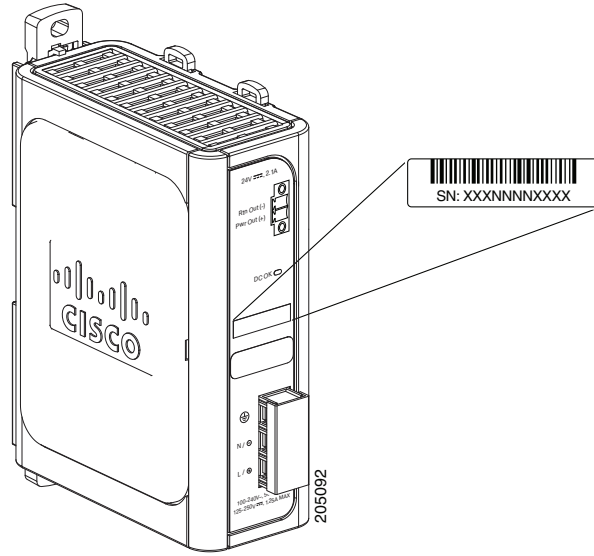

Figure 3-3 Serial Number Location for the Cisco PWR-IE3000-AC Power Converter





Technical Specifications

[Table A-1](#) lists the operating temperatures for the Cisco IE 3000 switches, expansion modules, and power convertor. [Table A-2](#) lists the technical specifications for the switches and modules. [Table A-3](#) lists the technical specifications for the Cisco IE 3000 switch power convertor.

The operating temperature for the Cisco IE 3000 switches, expansion modules, and the power convertor varies among environments, based on factors such as the system configuration and enclosure types. [Table A-1](#) describes three different environments and the operating temperature for each of the environments.

Table A-1 *Operating Temperature for the Cisco IE 3000 Switches and Power Convertor*

| | Industrial Automation and Hazardous Locations | Substation | Traffic Signal |
|-----------------|--|--|---|
| Enclosure types | Sealed enclosures For example: NEMA4, NEMA4X, NEMA12, NEMA13, IP54, and IP66. | Vented enclosures For example: NEMA1, IP20, and IP21. | Fan or blower-equipped enclosures For example: NEMA TS-2. Note The minimum airflow is 150 lfm ¹ . |

1. lfm = linear feet per minute.



Note

The safety certifications apply only to ambient temperatures under 140°F (60°C). However, the Cisco IE 3000 switch can function in the substation and traffic signal installations under the environmental conditions shown in [Table A-1](#).

Table A-2 Cisco IE 3000 Series Technical Specifications

| Environmental Ranges | |
|------------------------------------|--|
| Operating temperature ¹ | -40C to +74C <ul style="list-style-type: none"> -40C to +70C (Vented Enclosure Operating) -40C to +60C (Sealed Enclosure Operating) -34C to +74C (100LFM or more Fan or Blower equipped Enclosure Operating) -40C to +85C (Type Tested to +85C for 16 hours)² |
| Storage temperature | -40 to 185°F (-40 to 85°C) |
| Operating humidity | 5 to 95% (noncondensing) |
| Operating shock | 20 g at 11 ms |
| Operating altitude | Up to 13,000 ft (3962 m) |
| Storage altitude | Up to 40,000 ft (12,192 m) |
| Power Requirements | |
| DC input voltage | Cisco IE-3000-8TC and Cisco IE-3000-4TC: <ul style="list-style-type: none"> Range: 18 to 60 VDC Nominal: 24 or 48 VDC The DC-input power supply is an SELV circuit, and it can only be connected to another SELV circuit. Switch models with PoE capability require an additional power input connection to power the PoE ports. This connection requires 48/54 VDC @2.4A. <ul style="list-style-type: none"> PoE mode: 48VDC (nominal)/44-57 VDC (absolute range) PoE mode: 54VDC (nominal)/50-57 VDC (absolute range) |
| | Cisco IEM-3000-4PC and IEM-3000-4PC-4TC <ul style="list-style-type: none"> 48/54 VDC (nominal), 44/57 VDC (maximum) <p>Note PoE expansion modules receive power from a separate power supply or from site DC power.</p> |
| Maximum DC input current | Cisco IE-3000-8TC and Cisco IE-3000-4TC <ul style="list-style-type: none"> 1 A @ 48 VDC 2 A @ 24 VDC |
| | IEM-3000-4PC and IEM-3000-4PC-4TC: 2.4 A <p>Note PoE expansion modules receive power from a separate power supply or from site DC power.</p> |

Table A-2 Cisco IE 3000 Series Technical Specifications (continued)

| | |
|----------------------------|--|
| Max power consumption | <ul style="list-style-type: none"> • Cisco IE-3000-4TC, Cisco IE-3000-4TC-E —15.1 W • Cisco IE-3000-8TC, Cisco IE-3000-8TC-E —15.7 W • Cisco IEM-3000-8TM—2.8 W • Cisco IEM-3000-8FM—10.1 W • Cisco IEM-3000-4SM—7.6 W • Cisco IEM-3000-8SM—12.2 W • Cisco IEM-3000-4PC—7.3 W* • Cisco IEM-3000-4PC-4TC—7.9 W* <p>* Does not include POE power consumption</p> |
| Physical Dimensions | |
| Weight | <ul style="list-style-type: none"> • Cisco IE-3000-8TC: 4.4 lb (2 kg) • Cisco IE-3000-4TC: 4.4 lb (2 kg) • Cisco IEM-3000-8FM 3.2 lb (1.45 kg) • Cisco IEM-3000-8TM 2.05 lb (0.93 kg) • Cisco IEM-3000-4SM 2.5 lb (1.14 kg) • Cisco IEM-3000-8SM 3.04 lb (1.38 kg) • Cisco IEM-3000-4PC 2.4 lb (1.08 kg) • Cisco IEM-3000-4PC-4TC 2.6 lb (1.16 kg) |
| Dimensions (W x D x H) | <p>Cisco IE-3000-8TC and Cisco IE-3000-4TC: 6 x 4.4 x 5.8 in. (15.4 x 11.2 x 14.7 cm)</p> <p>Cisco IEM-3000-8TM, IEM-3000-8FM, IEM-3000-4SM, IEM-3000-8SM, IEM-3000-4PC, and IEM-3000-4PC-4TC: 3.6 x 4.4 x 5.8 in. (9.1 x 11.2 x 14.7 cm)</p> <p>Note Width includes the cosmetic end-caps. Height does not include the panel mount brackets. Depth is the distance from the rail.</p> |

1. Operating temperatures exceeding 60C are not covered by the product safety certifications and approvals. However, the switch can function in the installations under the environmental conditions listed.
2. The maximum operating temperature of the switch varies depending on the type of SFP module that you use.

**Note**

The technical specifications listed in Table A-2 for the Cisco IE-3000-8TC and IE-3000-4TC switches also apply to the Cisco IE-3000-8TC-E and Cisco IE-3000-4TC-E switches.

Table A-3 Technical Specifications for the Power Converter and AC-Input Power Supplies

| Environmental Ranges | |
|--------------------------------|---|
| Operating temperature | -29 to 165°F (-34 to 74°C) |
| Storage temperature | -40 to 185°F (-40 to 85°C) |
| Operating altitude | Up to 13,000 ft (3962 m) |
| Storage altitude | Up to 40,000 ft (12,192 m) |
| Thermal spacing | 3.54 in. (90 mm) exposed side 4.13 in. (105 mm) top and bottom |
| Power Requirements | |
| AC input voltages | Range: 85–264 VAC at 47–63 Hz Nominal: 115 VAC at 60 Hz or 230 VAC at 50 Hz |
| Maximum AC power input current | 0.75 A @ 230 VAC and 50 Hz or 1.25 A @ 115 VAC and 60 Hz |
| DC input voltages | Range: 88-300VDC Nominal: 125 VDC or 250 VDC |
| Maximum DC input current | 0.75 A at 220 VDC or 1.25 A at 150 VDC |
| DC output voltage | +24 VDC |
| DC output current | 2.1 A (max) |
| Hold-up time | Minimum 20 ms at full load and 115 VAC |
| Physical Dimensions | |
| Weight | 1.4 lb (0.63 kg) |
| Dimensions (W x D x H) | 2 x 4.62 x 5.81 in. (50.8 x 117.5 x 147.6 mm) Note Width includes the cosmetic end-caps. Height does not include the panel mount brackets. Depth is the distance from the rail. |

Table A-4 Hazardous Locations Standards

| Specification | Standards |
|----------------------|---|
| Hazardous Locations | ANSI/ISA 12.12.01-2011 UL 60079-0, 5th Ed, 2009-10-21 IEC 60079-15, 3rd Ed, 2009-7-17 CSA C22.2 No. 213-M1987 CAN/CSA E60079-15: 02 EN 60079-0:2009 EN 60079-15:2010 IEC 60079-0 4th Edition IEC 60079-15 5th Edition |



Installation In a Hazardous Environment

This chapter describes how to install your switch, interpret the power-on self-test (POST), and connect the switch to other devices when in a hazardous environment.

Read these topics, and perform the procedures in this order:

- [Preparing for Installation, page B-1](#)
- [Adding Modules to the Switch, page B-7](#)
- [Installing or Removing the Compact Flash Memory Card, page B-14](#)
- [Verifying Switch Operation, page B-15](#)
- [Installing the Switch, page B-29](#)
- [Connecting Power and Alarm Circuits, page B-39](#)
- [Connecting Destination Ports, page B-44](#)
- [Connecting the Switch to the Power Converter, page B-52](#)
- [Where to Go Next, page B-64](#)

Preparing for Installation

This section provides information about these topics:

- [Warnings, page B-2](#)
- [Installation Guidelines, page B-5](#)
- [Verifying Package Contents, page B-7](#)

Warnings

These warnings are translated into several languages in the Regulatory Compliance and Safety Information Guide.



Warning

Before working on equipment that is connected to power lines, remove jewelry (including rings, necklaces, and watches). Metal objects will heat up when connected to power and ground and can cause serious burns or weld the metal object to the terminals. Statement 43



Warning

Do not work on the system or connect or disconnect cables during periods of lightning activity. Statement 1001



Warning

Before performing any of the following procedures, ensure that power is removed from the DC circuit. Statement 1003



Warning

Read the installation instructions before you connect the system to its power source. Statement 1004



Warning

This unit is intended for installation in restricted access areas. A restricted access area can be accessed only through the use of a special tool, lock and key, or other means of security. Statement 1017



Warning

This equipment must be grounded. Never defeat the ground conductor or operate the equipment in the absence of a suitably installed ground conductor. Contact the appropriate electrical inspection authority or an electrician if you are uncertain that suitable grounding is available. Statement 1024



Warning

This unit might have more than one power supply connection. All connections must be removed to de-energize the unit. Statement 1028



Warning

Only trained and qualified personnel should be allowed to install, replace, or service this equipment. Statement 1030



Warning

Ultimate disposal of this product should be handled according to all national laws and regulations. Statement 1040



Warning

For connections outside the building where the equipment is installed, the following ports must be connected through an approved network termination unit with integral circuit protection. 10/100/1000 Ethernet Statement 1044

**Warning**

To prevent the system from overheating, do not operate it in an area that exceeds the maximum recommended ambient temperature of:
140°F (60°C) Statement 1047

**Warning**

Installation of the equipment must comply with local and national electrical codes. Statement 1074

**Warning**

To prevent airflow restriction, allow clearance around the ventilation openings to be at least:
4.13 in. (105 mm). Statement 1076

**Warning**

When you connect or disconnect the power and relay connector with power applied, an electrical arc can occur. This could cause an explosion in hazardous area installations. Be sure that power is removed from the switch and alarm circuit. Be sure that power cannot be accidentally turned on or verify that the area is nonhazardous before proceeding.

Failure to securely tighten the power and relay connector captive screws can result in an electrical arc if the connector is accidentally removed. Statement 1058

**Warning**

In switch installations in a hazardous location, the DC power source could be located away from the vicinity of the switch. Before performing any of the following procedures, locate the DC circuit to ensure that the power is removed and cannot be turned on accidentally, or verify that the area is nonhazardous before proceeding. Statement 1059

**Warning**

This equipment is supplied as “open type” equipment. It must be mounted within an enclosure that is suitably designed for those specific environmental conditions that will be present and appropriately designed to prevent personal injury resulting from accessibility to live parts. The interior of the enclosure must be accessible only by the use of a tool.

The enclosure must meet IP 54 or NEMA type 4 minimum enclosure rating standards. Statement 1063

**Warning**

If you connect or disconnect the console cable with power applied to the switch or any device on the network, an electrical arc can occur. This could cause an explosion in hazardous location installations. Be sure that power is removed or the area is nonhazardous before proceeding.

To verify switch operation, perform POST on the switch in a nonhazardous location before installation. Statement 1065

**Warning**

Use twisted-pair supply wires suitable for 86°F (30°C) above surrounding ambient temperature outside the enclosure. Statement 1067

**Warning**

This equipment is intended for use in a Pollution Degree 2 industrial environment, in overvoltage Category II applications (as defined in IEC publication 60664-1), and at altitudes up to 2000 meters without derating. Statement 1068

**Warning**

Explosion Hazard—Do not connect or disconnect wiring while the field-side power is on; an electrical arc can occur. This could cause an explosion in hazardous location installations. Be sure that power is removed or that the area is nonhazardous before proceeding. Statement 1081

**Warning**

Explosion Hazard—The area must be known to be nonhazardous before installing, servicing, or replacing the unit. Statement 1082

**Warning**

Exposure to some chemicals could degrade the sealing properties of materials used in the sealed relay device. Statement 381

**Warning**

Explosion Hazard—Substitution of components may impair suitability for Class I, Division 2/Zone 2. Statement 1083

**Caution**

This equipment is only suitable for use in Class I, Division 2, Groups A, B, C, D, or nonhazardous locations.

North American Hazardous Location Approval

The following information applies when operating this equipment in hazardous locations:

English: Products marked "Class I, Div 2, GP A, B, C, D" are suitable for use in Class I Division 2 Groups A, B, C, D, Hazardous Locations and nonhazardous locations only. Each product is supplied with markings on the rating nameplate indicating the hazardous location temperature code. When combining products within a system, the most adverse temperature code (lowest "T" number) may be used to help determine the overall temperature code of the system. Combinations of equipment in your system are subject to investigation by the local Authority Having Jurisdiction at the time of installation.

Français: Informations sur l'utilisation de cet équipement en environnements dangereux:

Les produits marqués "Class I, Div 2, GP A, B, C, D" ne conviennent qu'à une utilisation en environnements de Classe I Division 2 Groupes A, B, C, D dangereux et non dangereux. Chaque produit est livré avec des marquages sur sa plaque d'identification qui indiquent le code de température pour les environnements dangereux. Lorsque plusieurs produits sont combinés dans un système, le code de température le plus défavorable (code de température le plus faible) peut être utilisé pour déterminer le code de température global du système. Les combinaisons d'équipements dans le système sont sujettes à inspection par les autorités locales qualifiées au moment de l'installation.

EMC Environmental Conditions for Products Installed in the European Union

This section applies to products to be installed in the European Union.

The equipment is intended to operate under the following environmental conditions with respect to EMC:

- A separate defined location under the user's control.
- Earthing and bonding shall meet the requirements of ETS 300 253 or CCITT K27.
- AC-power distribution shall be one of the following types, where applicable: TN-S and TN-C as defined in IEC 364-3.

In addition, if equipment is operated in a domestic environment, interference could occur.

Installation Guidelines

When determining where to place the switch, observe these guidelines.

Environment and Enclosure Guidelines:

Review these environmental and enclosure guidelines before installation:

- This equipment is intended for use in a Pollution Degree 2 industrial environment, in overvoltage Category II applications (as defined in IEC publication 60664-1), at altitudes up to 9842 ft (3 km) without derating.
- This equipment is considered Group 1, Class A industrial equipment, according to IEC/CISPR Publication 11. Without appropriate precautions, there may be potential difficulties ensuring electromagnetic compatibility in other environments due to conducted as well as radiated disturbance.
- This equipment is supplied as open-type equipment. It must be mounted within an enclosure that is suitably designed for those specific environmental conditions that will be present and appropriately designed to prevent personal injury resulting from accessibility to live parts. The enclosure must have suitable flame-retardant properties to prevent or minimize the spread of flame, complying with a flame-spread rating of 5VA, V2, V1, V0 (or equivalent) if nonmetallic. The interior of the enclosure must be accessible only by the use of a tool. Subsequent sections of this publication might contain additional information regarding specific enclosure-type ratings that are required to comply with certain product safety certifications.
- The equipment should be mounted in a suitable enclosure rated to at least IP54 as defined in EN60529 and Pollution Degree 2 as defined in IEC 60664-1 and used within their rated electrical and environmental ratings.
- Provision should be made, either in the apparatus or external to the apparatus, to prevent the rated voltage from being exceeded by transient disturbances of more than 40 percent.

Other Guidelines

These are other installation guidelines:

**Caution**

Proper ESD protection is required whenever you handle Cisco equipment. Installation and maintenance personnel should be properly grounded by using ground straps to eliminate the risk of ESD damage to the switch.

Do not touch connectors or pins on component boards. Do not touch circuit components inside the switch. When not in use, store the equipment in appropriate static-safe packaging.

- Make sure that all connectors and caps are securely tightened to properly seal the connections against leaks and to maintain IP enclosure-type requirements.
- Personnel responsible for the application of safety-related programmable electronic systems (PES) shall be aware of the safety requirements in the application of the system and shall be trained in using the system.
- This product is grounded through the DIN rail to chassis ground. Use zinc-plated yellow-chromate steel DIN rail to assure proper grounding. The use of other DIN rail materials (such as aluminum, plastic, and so on) that can corrode, oxidize, or are poor conductors can result in improper or intermittent grounding. Secure the DIN rail to the mounting surface approximately every 7.8 in. (200 mm), and use end-anchors appropriately.

When determining where to place the switch, observe these guidelines:

- Before installing the switch, first verify that the switch is operational by powering it on and running POST. Follow the procedures in the [“Verifying Switch Operation” section on page 2-13](#).
- For 10/100 ports and 10/100/1000 ports, the cable length from a switch to an attached device cannot exceed 328 feet (100 meters).
- For 100BASE-FX fiber-optic ports, the cable length from a switch to an attached device cannot exceed 6562 ft (2 km).
- For 100BASE-X SFP ports, cable length supported is dependent on the type of SFP transceiver installed.
- Operating environment is within the ranges listed in [Appendix A, “Technical Specifications.”](#)
- Clearance to front and rear panels meets these conditions:
 - Front-panel LEDs can be easily read.
 - Access to ports is sufficient for unrestricted cabling.
 - Front-panel direct current (DC) power and relay connector is within reach of the connection to the DC power source.
- Airflow around the switch and through the vents is unrestricted. To prevent the switch from overheating, there must be the following minimum clearances:
 - Top and bottom: 4.13 in. (105 mm)
 - Exposed side (not connected to the module): 3.54 in. (90 mm)
 - Front: 2.56 in. (65 mm)
- Temperature surrounding the unit does not exceed 140°F (60°C).

**Note**

When the switch is installed in an industrial enclosure, the temperature within the enclosure is greater than normal room temperature outside the enclosure.

The temperature inside the enclosure cannot exceed 140°F (60°C), the maximum ambient enclosure temperature of the switch.

- Cabling is away from sources of electrical noise, such as radios, power lines, and fluorescent lighting fixtures.
- Connect the unit only to a Class 2 DC power source.

Verifying Package Contents

Carefully remove the contents from the shipping container, and check each item for damage. If any item is missing or damaged, contact your Cisco representative or reseller for support. Return all packing materials to the shipping container and save them.

The switch is shipped with these items:

- Documentation CD that includes:
 - *Cisco IE 3000 Switch Getting Started Guide* (in English, German, French, Spanish, Italian, Japanese, and simplified Chinese)
 - *Regulatory Compliance and Safety Information for the Cisco IE 3000 Switch*
- *Regulatory Compliance and Safety Information for the Cisco IE 3000 Switch* (safety warnings translated in German)
- Two power and relay connectors
- RJ-45 to DB-9 console port adapter cable

**Note**

To connect the switch functional ground, you need a ring terminal lug (such as Thomas & Bett part number RC10-14 or equivalent).

If you want to connect a terminal to the switch console port, you need to provide an RJ-45-to-DB-25 female DTE adapter. You can order a kit (part number ACS-DSBUASYN=) with that adapter from Cisco.

You can order a kit containing four spare latches (DINCLP-IE3000=) from Cisco.

For multimode (MM) connections, you can connect a 100BASE-FX port to a port on a target device by using an dual-LC connector.

Adding Modules to the Switch

The Cisco IE-3000-4TC or the Cisco IE-3000-8TC switch can operate as standalone devices with four or eight Fast Ethernet ports, respectively. To increase the number of Fast Ethernet ports by 8 or 16, you can connect the Cisco IEM-3000-8TM and the Cisco IEM-3000-8FM expansion modules. PoE-capable ports can also be added to the switch by installing either the IEM-3000-4PC or the IEM-3000-4PC-4TC PoE expansion modules. Depending on the mix of switches and expansion modules, you can have up to 24 Fast Ethernet ports.

**Note**

The expansion modules cannot operate as standalone devices; a switch is required for the expansion module to operate.

Expansion Module Configurations

Both the IE-3000-4TC and the IE-3000-8TC switches can be configured with one or two expansion modules to increase the number and types of ports for the switch. [Table B-1](#) lists the supported port combinations of switch and expansion modules. The table also provides a breakdown of the type and quantity of ports for a particular switch expansion module combination.

Table B-1 *Cisco IE-3000-4TC and Cisco IE-3000-8TC Switch Expansion Module Configurations and Port Types*

| Expansion Module Configurations | | Port Types and Quantity (Including Switch Ports) | |
|---------------------------------|------------------------|--|---|
| Expansion Module 1 | Expansion Module 2 | IE-3000-4TC Switch | IE-3000-8TC Switch |
| — | — | 10/100FE—4 | 10/100FE—8 |
| Cisco IEM-3000-4PC | — | 10/100FE—4 10/100BASE-T—4 | 10/100FE—8 10/100BASE-T—4 |
| Cisco IEM-3000-4PC | Cisco IEM-3000-4PC | 10/100FE—4 10/100BASE-T—8 | 10/100FE—8 10/100BASE-T—8 |
| Cisco IEM-3000-4PC | Cisco IEM-3000-4PC-4TC | 10/100FE—4 10/100BASE-T—12 | 10/100FE—8 10/100BASE-T ² —12 |
| Cisco IEM-3000-4PC | Cisco IEM-3000-4SM | 10/100FE—4 100BASE-X—4 10/100BASE-T—4 | 10/100FE—8 100BASE-X—4 10/100BASE-T—4 |
| Cisco IEM-3000-4PC | Cisco IEM-3000-8FM | 10/100FE—4 100FX—8 10/100BASE-T—4 | 10/100FE—8 100FX—8 10/100BASE-T—4 |
| Cisco IEM-3000-4PC | Cisco IEM-3000-8SM | 10/100FE—4 100BASE-X—8 10/100BASE-T—4 | 10/100FE—8 100BASE-X—8 10/100BASE-T—4 |
| Cisco IEM-3000-4PC | Cisco IEM-3000-8TM | 10/100FE—12 10/100BASE-T—4 | 10/100FE—16 10/100BASE-T—4 |
| Cisco IEM-3000-4PC-4TC | — | 10/100FE—4 10/100BASE-T—8 | 10/100FE—8 10/100BASE-T—8 |
| Cisco IEM-3000-4PC-4TC | Cisco IEM-3000-4PC | 10/100FE—4 10/100BASE-T—12 | 10/100FE—8 10/100BASE-T—12 |
| Cisco IEM-3000-4PC-4TC | Cisco IEM-3000-4PC-4TC | 10/100FE—4 10/100BASE-T—16 | 10/100FE—8 10/100BASE-T—16 |
| Cisco IEM-3000-4PC-4TC | Cisco IEM-3000-4SM | 10/100FE—4 100BASE-X—4 10/100BASE-T—4 | 10/100FE—8 100BASE-X—4 10/100BASE-T—4 |

Table B-1 Cisco IE-3000-4TC and Cisco IE-3000-8TC Switch Expansion Module Configurations and Port Types (continued)

| Expansion Module Configurations | | Port Types and Quantity (Including Switch Ports) | |
|---------------------------------|------------------------|--|---|
| Expansion Module 1 | Expansion Module 2 | IE-3000-4TC Switch | IE-3000-8TC Switch |
| Cisco IEM-3000-4PC-4TC | Cisco IEM-3000-8FM | 10/100FE—4 100FX—8 10/100BASE-T—8 | 10/100FE—8 100FX—8 10/100BASE-T—8 |
| Cisco IEM-3000-4PC-4TC | Cisco IEM-3000-8SM | 10/100FE—4 100BASE-X—8 10/100BASE-T—8 | 10/100FE—8 100BASE-X—8 10/100BASE-T—8 |
| Cisco IEM-3000-4PC-4TC | Cisco IEM-3000-8TM | 10/100FE—12 10/100BASE-T—8 | 10/100FE—16 10/100BASE-T—8 |
| Cisco IEM-3000-4SM | — | 10/100FE—4 100BASE-X—4 | 10/100FE—8 100BASE-X—4 |
| Cisco IEM-3000-4SM | Cisco IEM-3000-4PC | 10/100FE—4 100BASE-X—4 10/100BASE-T—4 | 10/100FE—8 100BASE-X—4 10/100BASE-T—4 |
| Cisco IEM-3000-4SM | Cisco IEM-3000-4PC-4TC | 10/100FE—4 100BASE-X—4 10/100BASE-T—8 | 10/100FE—8 100BASE-X—4 10/100BASE-T—8 |
| Cisco IEM-3000-4SM | Cisco IEM-3000-4SM | 10/100FE—4 100BASE-X—4 10/100BASE-T—4 | 10/100FE—8 100BASE-X—4 10/100BASE-T—4 |
| Cisco IEM-3000-4SM | Cisco IEM-3000-8FM | 10/100FE—4 100FX—8 100BASE-X—4 | 10/100FE—8 100FX—8 100BASE-X—4 |
| Cisco IEM-3000-4SM | Cisco IEM-3000-8SM | 10/100FE—4 100BASE-X—12 | 10/100FE—8 100BASE-X—12 |
| Cisco IEM-3000-4SM | Cisco IEM-3000-8TM | 10/100FE—12 100BASE-X—4 | 10/100FE—16 100BASE-X—4 |
| Cisco IEM-3000-8FM | — | 10/100FE—4 100FX—8 | 10/100FE—8 100FX—8 |
| Cisco IEM-3000-8SM | — | 10/100FE—4 100BASE-X—8 | 10/100FE—8 100BASE-X—8 |
| Cisco IEM-3000-8TM | — | 10/100FE—12 | 10/100FE—16 |
| Cisco IEM-3000-8TM | Cisco IEM-3000-4PC | 10/100FE—12 10/100BASE-T—4 | 10/100FE—16 10/100BASE-T—4 |
| Cisco IEM-3000-8TM | Cisco IEM-3000-4PC-4TC | 10/100FE—12 10/100BASE-T—8 | 10/100FE—16 10/100BASE-T—8 |
| Cisco IEM-3000-8TM | Cisco IEM-3000-4SM | 10/100FE—12 100BASE-X—4 | 10/100FE—16 100BASE-X—4 |
| Cisco IEM-3000-8TM | Cisco IEM-3000-8FM | 10/100FE—12 100FX—8 | 10/100FE—16 100FX—8 |

Table B-1 Cisco IE-3000-4TC and Cisco IE-3000-8TC Switch Expansion Module Configurations and Port Types (continued)

| Expansion Module Configurations | | Port Types and Quantity (Including Switch Ports) | |
|---------------------------------|--------------------|--|----------------------------|
| Expansion Module 1 | Expansion Module 2 | IE-3000-4TC Switch | IE-3000-8TC Switch |
| Cisco IEM-3000-8TM | Cisco IEM-3000-8SM | 10/100FE—12 100BASE-X—8 | 10/100FE—16 100BASE-X—8 |
| Cisco IEM-3000-8TM | Cisco IEM-3000-8TM | 10/100FE—20 | 10/100FE—24 |

Figure B-1 shows four sample combinations of the Cisco IE-3000-4TC switch and expansion modules. A full list of combinations is contained in Table B-1

**Note**

The switch and expansion module sample combinations illustrated in Figure B-1 show an IE-3000-4TC switch. The same sample combinations could also be used with the Cisco IE-3000-8TC switch.

**Note**

Due to power constraints, a configuration that includes either IE 3000 switch and two IEM-3000-8SM expansion modules is not supported. Also, the only expansion modules that can be attached to the right (expansion module 2) of an IEM-3000-8SM expansion module are the IEM-3000-4PC and the IEM-3000-4PC-4TC PoE expansion modules due to the two PoE expansion modules requiring their own dedicated power supply. All other expansion modules can not be attached to the right of the IEM-3000-8SM expansion module.

Figure B-1 Sample Combinations of Expansion Modules



| | | | |
|----------|--|----------|--|
| 1 | IE-3000-4TC switch with IEM-3000-8TM and Cisco IEM-3000-8FM expansion modules (12 FE and 8 FX ports) | 3 | IE-3000-4TC switch with one IEM-3000-8TM expansion modules (12 FE ports) |
| 2 | IE-3000-4TC switch with one IEM-3000-8FM expansion module (4 FE and 8 FX ports) | 4 | IE-3000-4TC switch with two IEM-3000-8TM expansion modules (20 FE ports) |

Connecting Modules



Note

Expansion modules are not hot-swappable. You must turn off power to the switch before adding or removing an expansion module.

To connect the expansion modules to the switch, follow these steps:

- Step 1** Remove the side panel by firmly grasping both sides of it in the middle and pulling it outward. If necessary, use a screwdriver to pry open the side panel. See [Figure B-2](#).

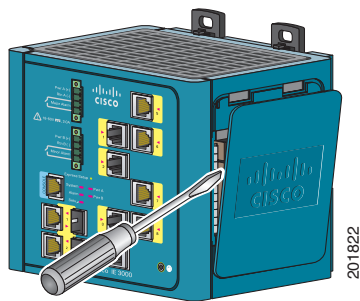
Figure B-2 Opening the Side Panel of the Cisco IE-3000-8TC Switch



- Step 2** Remove the EMI protective cover from the interface connector on the switch. See [Figure B-3](#).

Figure B-3 Removing the EMI Cover

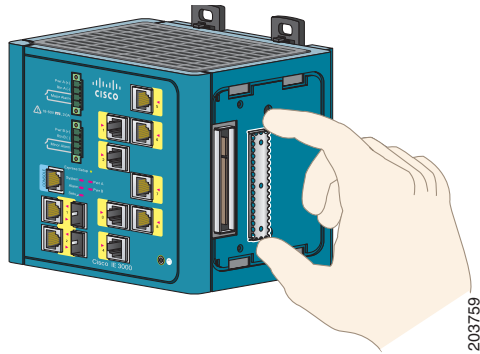

- Step 3** Push up the upper module latches (at the top of the switch and the expansion module). See [Figure B-4](#). Push down the lower module latches (at the bottom of the switch and the expansion module).

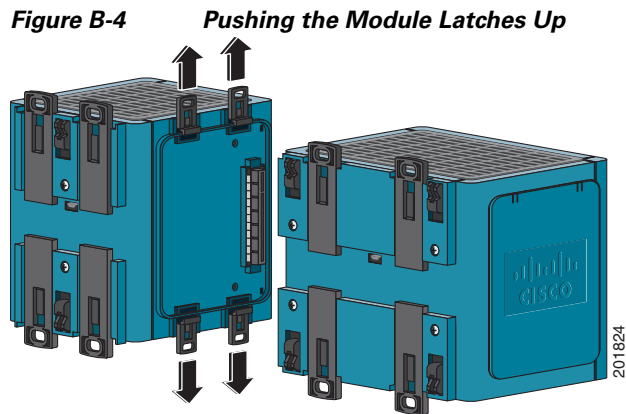

- Step 4** Align the connectors on the switch and the module, and slide the switch and the expansion module together to make the connection. See [Figure B-5](#).

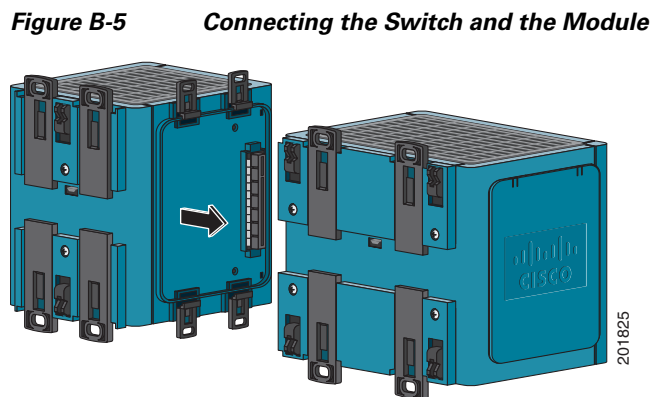

- Step 5** Push the upper module latches down and the lower latches up. See [Figure B-6](#).

Figure B-6 Pushing the Module Latches In

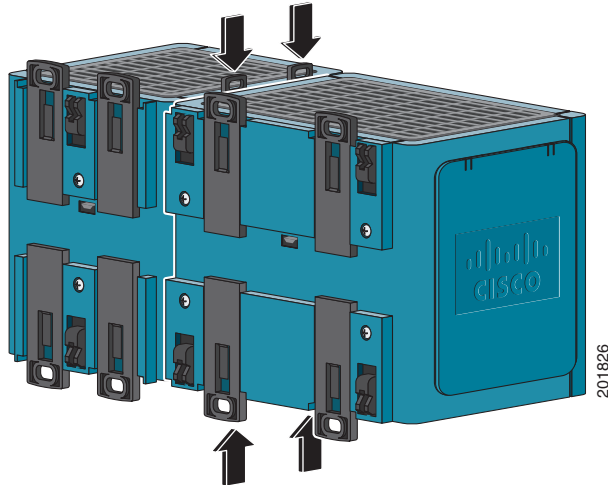

- Step 6** If you are going to install a second expansion module to the switch expansion module combination, follow [Step 1](#) to [Step 5](#)



Note Refer to [Table B-1](#) for a list of supported switch and expansion module combinations.

Installing or Removing the Compact Flash Memory Card

The switches store Cisco IOS software images and switch configurations on a removable flash memory card. You can replace the switch without reconfiguring it. The switch ships with the compact flash memory card installed. Verify that the card is in place on the bottom of the switch.



Warning

Do not insert or remove the compact flash card while power is on; an electrical arc can occur. This could cause an explosion in hazardous location installations. Be sure that power is removed or the area is nonhazardous before proceeding. Statement 379

Follow these directions to remove or replace the compact flash memory card:

- Step 1** Locate the compact flash memory card slot on the bottom of the switch. See [Figure B-7](#).

Figure B-7 Removing the Compact Flash Memory Card from the Switch

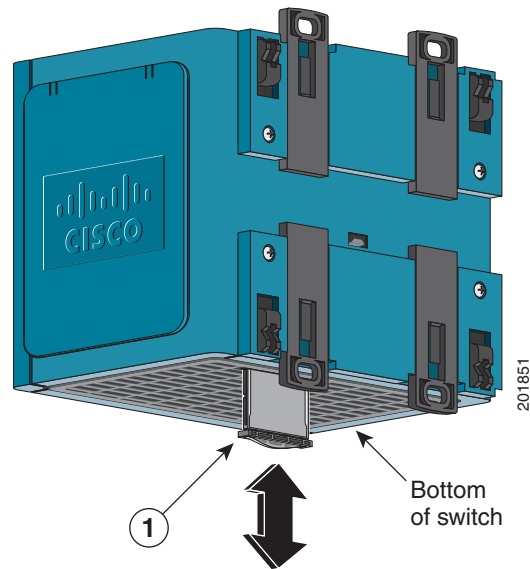

- Step 2** Install or remove the card, as desired:
- To remove the card, grasp the card top, and pull it out. Place it in an antistatic bag to protect it from static discharge.
 - To install a card, slide it into the slot, and press it firmly in place. The card is keyed so that you cannot insert it the wrong way.

Verifying Switch Operation

Before installing the switch in its final location, power on the switch, and verify that the switch passes the power-on self-test (POST).

These sections describe the steps required to connect a PC or terminal to the switch console port, to power on the switch, and to observe POST results:

- [Connecting a PC or a Terminal to the Console Port, page B-16](#)
- [Verifying Switch Operation, page B-15](#)

Connecting a PC or a Terminal to the Console Port

To connect a PC to the console port, use the supplied RJ-45-to-DB-9 adapter cable. To connect a terminal to the console port, you need to provide an RJ-45-to-DB-25 female DTE adapter. You can order a kit (part number ACS-DSBUASYN=) with that adapter from Cisco. For console-port and adapter-pinout information, see the [“Cable and Adapter Specifications” section on page C-5](#).

The PC or terminal must support VT100 terminal emulation. The terminal-emulation software—frequently a PC application such as HyperTerminal or Procomm Plus—makes communication between the switch and your PC or terminal possible during the POST.



Warning

If you connect or disconnect the console cable with power applied to the switch or any device on the network, an electrical arc can occur. This could cause an explosion in hazardous location installations. Be sure that power is removed or the area is nonhazardous before proceeding.

To verify switch operation, perform POST on the switch in a nonhazardous location before installation. Statement 1065

Follow these steps to connect the PC or terminal to the switch:

-
- Step 1** Make sure that your terminal-emulation software is configured to communicate with the switch using hardware flow control.
- Step 2** Configure the baud rate and data format of the PC or terminal to match these console-port default characteristics:
- 9600 baud
 - Eight data bits
 - One stop bit
 - No parity

After you get access to the switch, you can change the port baud rate. See the switch software configuration guide for instructions.

- Step 3** Insert the adapter cable in the console port. See [Figure B-8](#). (See the [“Cable and Adapter Specifications” section on page C-5](#) for pinout descriptions.)

Figure B-8 Connecting to the Console Port

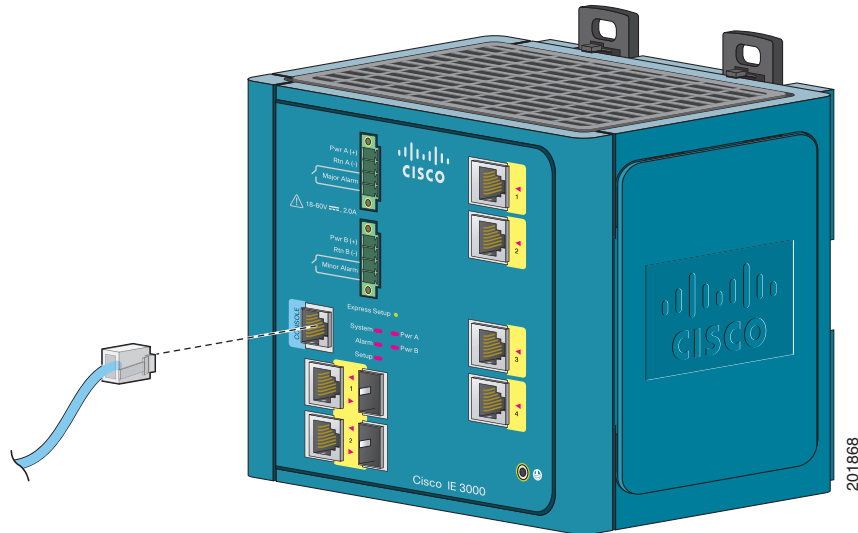

- Step 4** Attach the appropriate adapter to the terminal, if needed.
- Step 5** Connect the other end of the adapter cable to the PC or terminal adapter.
- Step 6** Start the terminal-emulation software on the PC.

Connecting the Protective Ground and DC Power

These sections describe the steps required to connect a protective ground and DC power to the switch:

- [Grounding the Switch, page B-18](#)
- [Wiring the DC Power Source, page B-20](#)
- [Attach the Power and Relay Connector to the Switch, page B-25](#)



Note

The Cisco IE 3000 switch can be used with an optional AC/DC power converter (PWR-IE3000-AC).

For instructions on how to connect the power converter to the switch, see the [“Connecting the Switch to the Power Converter”](#) section on page B-52.

Locate the power and relay connector in the switch accessory kit.



Note

You can get replacement power and relay connectors (PWR-IE3000-CNCT=) by calling Cisco Technical Support. See the [“Obtaining Documentation, Obtaining Support, and Security Guidelines”](#) section on page viii.

Obtain these necessary tools and equipment:

- Ratcheting torque flathead screwdriver that exerts up to 15 inch-pounds (in-lb) of pressure
- Ring terminal lug (such as Thomas & Bett part number 10RCR or equivalent)
- Crimping tool (such as Thomas & Bett part number WT2000, ERG-2001, or equivalent)
- 10-gauge copper ground wire (such as Belden part number 9912 or equivalent)
- For DC power connections, use UL- and CSA-rated, style 1007 or 1569 twisted-pair copper appliance wiring material (AWM) wire (such as Belden part number 9318).
- Wire-stripping tools for stripping 10- and 18-gauge wires

Grounding the Switch

To ground the switch to earth ground by using the ground screw, follow these steps. Make sure to follow any grounding requirements at your site.



Warning

This equipment must be grounded. Never defeat the ground conductor or operate the equipment in the absence of a suitably installed ground conductor. Contact the appropriate electrical inspection authority or an electrician if you are uncertain that suitable grounding is available. Statement 1024



Warning

This equipment is intended to be grounded to comply with emission and immunity requirements. Ensure that the switch functional ground lug is connected to earth ground during normal use. Statement 1064



Note

Use at least a 4mm² conductor to connect to the external grounding screw.

Step 1

Use a standard Phillips screwdriver or a ratcheting torque flathead screwdriver with a Phillips head to remove the ground screw from the front panel of the switch. Store the ground screw for later use.



Caution

To make sure that the equipment is reliably connected to earth ground, follow the grounding procedure instructions, and use a UL-listed ring terminal lug suitable for number 10-to-12 AWG wire, such as Thomas & Bett part number 10RCR or equivalent.

Step 2

Use a wire-stripping tool to strip the 10- gauge wire to 0.5 inch (12.7 mm) ± 0.02 inch (0.5 mm). See [Figure B-9](#).

Figure B-9 Stripping the Ground Wire

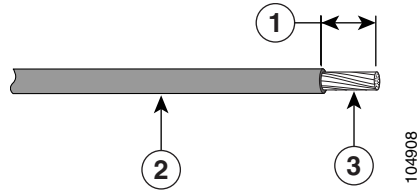

| | | | |
|----------|---------------------------------------|----------|-----------|
| 1 | 0.5 in. (12.7 mm) ± 0.02 in. (0.5 mm) | 3 | Wire lead |
| 2 | Insulation | | |

Step 3 Insert the ground wire into the ring terminal lug, and using a crimping tool, crimp the ring terminal to the wire.

Figure B-10 Crimping the Ring Terminal

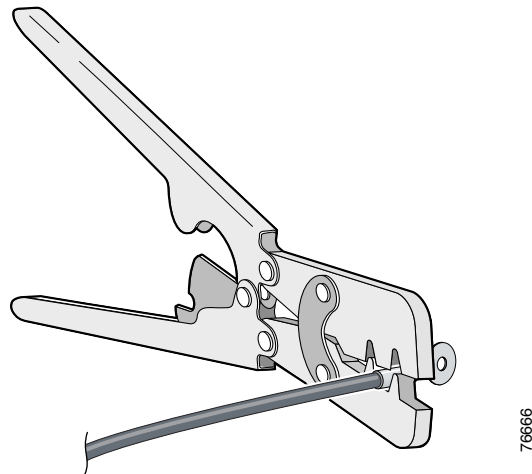

- Step 4** Slide the ground screw through the ring terminal.
- Step 5** Insert the ground screw into the functional ground screw opening on the front panel.
- Step 6** Use a ratcheting torque screwdriver to tighten the ground screw and ring terminal lug to the switch front panel to 8.5 in-lb. See [Figure B-11](#).

Figure B-11 Torquing Ground-Lug Screws

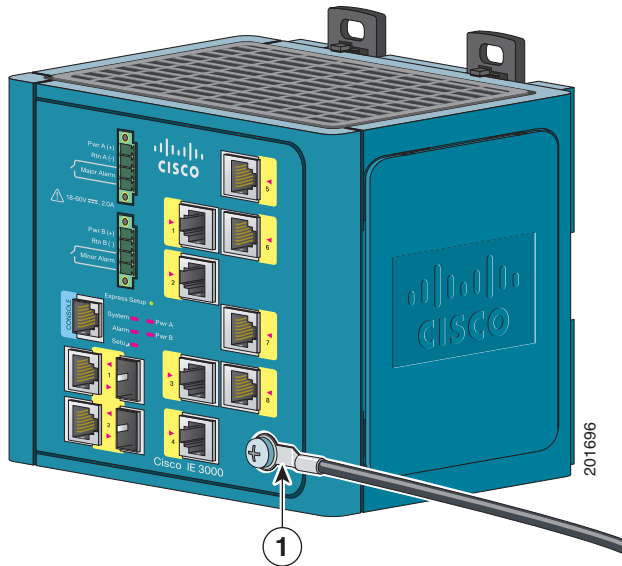

| | |
|---|--------------|
| 1 | Ground cable |
|---|--------------|

Step 7 Attach the other end of the ground wire to a grounded bare metal surface, such as a ground bus, a grounded DIN rail, or a grounded bare rack.

Wiring the DC Power Source

Read these warnings before wiring the DC power source:

Caution

This product is intended to be supplied by a Listed Class 2 power source marked with "Class 2" and rated from 18 to 60 VDC ± 0 VDC, 2.1 A.

Warning

A readily accessible two-poled disconnect device must be incorporated in the fixed wiring. Statement 1022

Warning

This product relies on the building's installation for short-circuit (overcurrent) protection. Ensure that the protective device is rated not greater than: 5A. Statement 1005

Warning

Installation of the equipment must comply with local and national electrical codes. Statement 1074

Warning

Before performing any of the following procedures, ensure that power is removed from the DC circuit. Statement 1003

Warning

Only trained and qualified personnel should be allowed to install, replace, or service this equipment. Statement 1030

Caution

You must connect the switch only to a DC-input power source that has an input supply voltage from 18 to 60 VDC \pm 0 VDC. If the supply voltage is not in this range, the switch might not operate properly or might be damaged.

Caution

For wire connections to the power and relay connector, you must use UL- and CSA-rated, style 1007 or 1569 twisted-pair copper appliance wiring material (AWM) wire (such as Belden part number 9318).

To wire the switch to the optional AC/DC converter, go to the [“Connecting the Switch to the Power Converter” section on page B-52.](#)

To wire the switch to a DC-input power source, follow these steps:

Step 1 Locate the power and relay connector (see [Figure B-12](#)).

Figure B-12 Power and Relay Connector

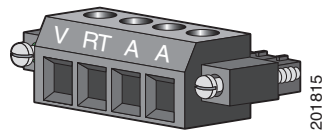

Step 2 Identify the positive and return DC power connections on the connector. The positive DC power connection is labeled V, and the return is the adjacent connection labeled RT. See [Figure B-12](#).

Step 3 Measure two strands of twisted-pair copper wire (18-to-20 AWG) long enough to connect to the DC power source.

Step 4 Using an 18-gauge wire-stripping tool, strip each of the two twisted pair wires coming from each DC-input power source to 0.25 inch (6.3 mm) \pm 0.02 inch (0.5 mm). Do not strip more than 0.27 inch (6.8 mm) of insulation from the wire. Stripping more than the recommended amount of wire can leave exposed wire from the power and relay connector after installation.

Figure B-13 Stripping the Power Connection Wire

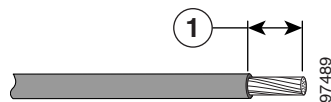

| | |
|----------|---|
| 1 | 0.25 in. (6.3 mm) \pm 0.02 in. (0.5 mm) |
|----------|---|

- Step 5** Insert the exposed part of the positive wire into the connection labeled V and the exposed part of the return wire into the connection labeled RT. See [Figure B-14](#). Make sure that you cannot see any wire lead. Only wire *with insulation* should extend from the connector.

**Warning**

An exposed wire lead from a DC-input power source can conduct harmful levels of electricity. Be sure that no exposed portion of the DC-input power source wire extends from the power and relay connector. **Statement 122**

Figure B-14 Inserting Wires in the Power and Relay Connector

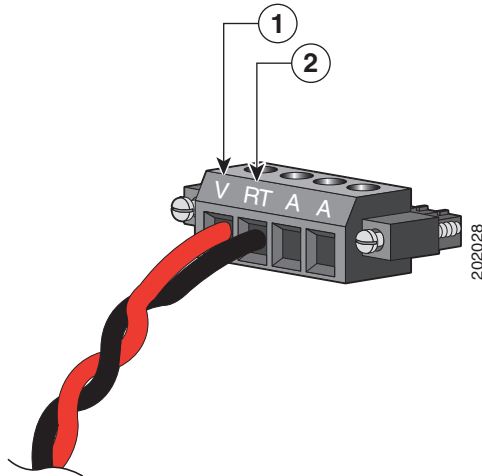

| | | | |
|----------|----------------------------------|----------|--------------------------------|
| 1 | Power source positive connection | 2 | Power source return connection |
|----------|----------------------------------|----------|--------------------------------|

- Step 6** Use a ratcheting torque flathead screwdriver to torque the power and relay connector captive screws (above the installed wire leads) to 2.2 in-lb (0.25 Nm). See [Figure B-15](#).

**Caution**

Do not over-torque the power and relay connector captive screws. The torque should not exceed 2.2 in-lb (0.25 Nm).

Figure B-15 Torquing the Power and Relay Connector Captive Screws

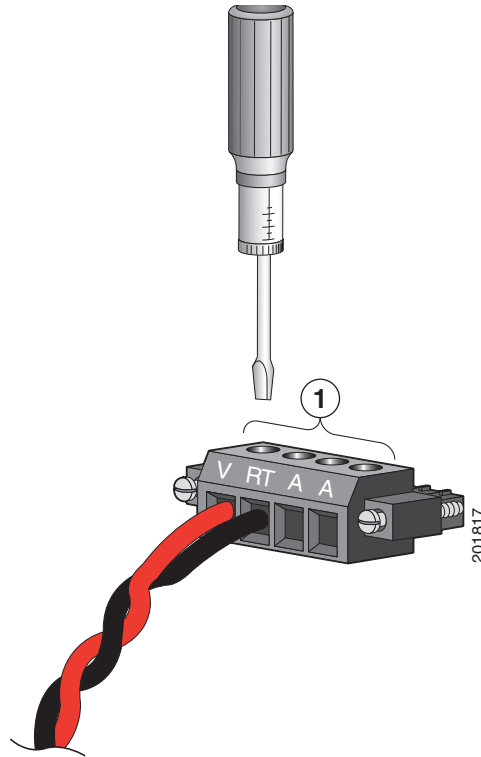

1 Power and relay connector captive screws

- Step 7** Connect the other end of the positive wire (the one connected to V) to the positive terminal on the DC power source, and connect the other end of the return wire (the one connected to RT) to the return terminal on the DC power source.
- When you are testing the switch, one power connection is sufficient. If you are installing the switch and are using a second power source, repeat [Step 4](#) through [Step 7](#) using a second power and relay connector.

Figure B-16 shows the completed DC-input wiring on a power and relay connector for a primary power source and an optional secondary power source.

Figure B-16 Completed DC Power Connections on the Power and Relay Connector

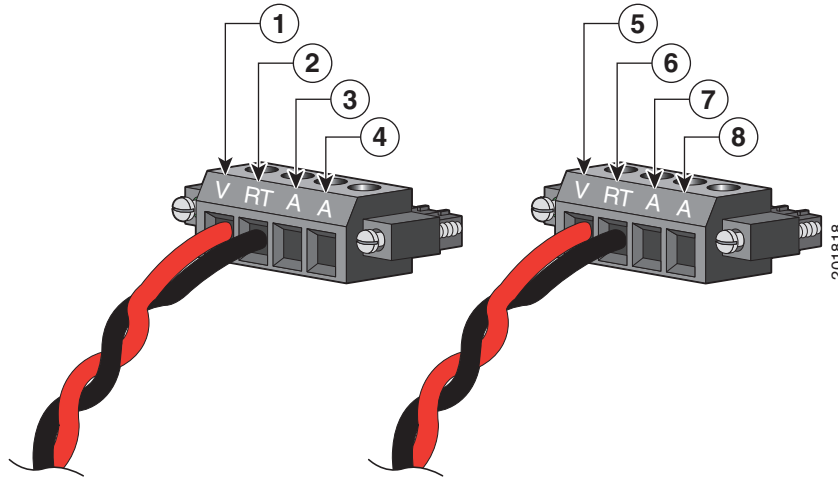

| | | | |
|---|--|---|--|
| 1 | Power source A positive connection | 5 | Power source B positive connection |
| 2 | Power source A return connection | 6 | Power source B return connection |
| 3 | External device 1, relay wire connection | 7 | External device 2, relay wire connection |
| 4 | External device 1, relay wire connection | 8 | External device 2, relay wire connection |

If your power source is -48 VDC, this table describes the your wiring connections for Figure B-16.

| | | | |
|---|--|---|--|
| 1 | Power source A return connection | 5 | Power source B return connection |
| 2 | Power source A -48 VDC connection | 6 | Power source B -48 VDC connection |
| 3 | External device 1, relay wire connection | 7 | External device 2, relay wire connection |
| 4 | External device 1, relay wire connection | 8 | External device 2, relay wire connection |

Step 8 (Optional) If you plan to connect external alarm devices to the alarm relays and the switch is already installed, go to the [“Wiring the External Alarms”](#) section on page B-41. Otherwise, go to the [“Verifying Switch Operation”](#) section on page B-15.

Attach the Power and Relay Connector to the Switch

Follow these steps to attach the power and relay connectors to the front panel of the switch.

- Step 1** Insert the power and relay connector into the Pwr A receptacle on the switch front panel. See [Figure B-17](#).



Warning

When you connect or disconnect the power and relay connector with power applied, an electrical arc can occur. This could cause an explosion in hazardous area installations. Be sure that power is removed from the switch and alarm circuit. Be sure that power cannot be accidentally turned on or verify that the area is nonhazardous before proceeding.

Failure to securely tighten the power and relay connector captive screws can result in an electrical arc if the connector is accidentally removed. Statement 1058

Figure B-17 Connecting the Power and Relay Connector to the Switch

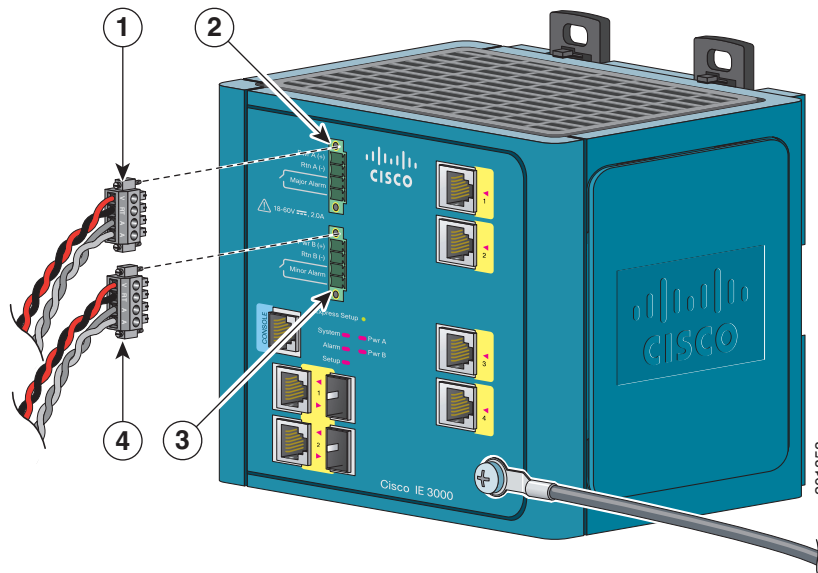

| | | | |
|----------|--------------------------|----------|--------------------------|
| 1 | Power source A connector | 3 | Pwr B receptacle |
| 2 | Pwr A receptacle | 4 | Power source B connector |

- Step 2** Use a ratcheting torque flathead screwdriver to tighten the captive screws on the sides of the power and relay connector.

When you are testing the switch, one power source is sufficient. If you are installing the switch and are using a second power source, repeat this procedure for the second power and relay connector (Pwr B), which installs just below the primary power connector (Pwr A).

When you are installing the switch, secure the wires coming from the power and relay connector so that they cannot be disturbed by casual contact. For example, use tie wraps to secure the wires to the rack.

Attaching DC Power to the PoE Expansion Modules

If your switch configuration includes either the IEM-3000-4PC or the IEM-3000-4PC-4TC PoE expansion modules, you must attach source DC directly to the expansion module's Input DC terminal block. Source DC can come from either the PWR-IE65W-PC-DC, a DC-input power supply, the PWR-IE65W-PC-AC, an AC-input power supply, or from site source DC; however, site source power voltage must be 48–54VDC.

If you are using the above Cisco PoE AC/DC power supplies, you can power up to 4 PoE or 2 PoE+ devices on each expansion module.

To attach site source DC to the expansion module:



Warning

The equipment is to be connected to a UL Listed, limited power source. Statement 170



Warning

When you connect or disconnect the power and relay connector with power applied, an electrical arc can occur. This could cause an explosion in hazardous area installations. Be sure that power is removed from the switch and alarm circuit. Be sure that power cannot be accidentally turned on or verify that the area is nonhazardous before proceeding.

Failure to securely tighten the power and relay connector captive screws can result in an electrical arc if the connector is accidentally removed. Statement 1058

- Step 1** Verify that power is off to the DC circuit you are going to attach to the DC-input power supply. As an added precaution, place the appropriate safety flag and lockout devices at the source power circuit breaker, or place a piece of adhesive tape over the circuit breaker handle to prevent accidental power restoration while you are working on the circuit.
- Step 2** Measure a length of twisted-pair copper wire long enough to connect the site source DC to the PoE expansion module's Input DC terminal block.
- For DC connections from the site source DC to the PoE expansion module, use 18-AWG (0.75 mm²) twisted-pair copper wire, such as Belden part number 9344 or the appropriate type, wire size, and color-code for your country.
- Step 3** Using a wire-stripping tool, strip both ends of the twisted pair wires to 0.25 inch (6.3 mm) ± 0.02 inch (0.5 mm). Do not strip more than 0.27 inch (6.8 mm) of insulation from the wires.
- Step 4** Attach the twisted-pair wire leads into the site source DC positive (+) and negative (-) connectors. Verify that only insulated wire extends from the connectors.
- Step 5** Secure the twisted-pair leads to the source DC connectors.
- Step 6** Connect the other end of the twisted-pair wire leads to the Input DC terminal block connectors on the PoE expansion module making sure that only insulated wire extends beyond the terminal block.
- Verify that the positive (+) wire goes from the source DC positive (+) connector to the positive (+) connector on the expansion module and that the source DC negative (-) wire goes to the negative (-) connector on the expansion module.
- Step 7** Secure the twisted-pair leads to the terminal block connectors using the torque ratchet screwdriver to tighten the expansion module terminal block screws.



Note Do not overtighten the terminal block screws. The torque on the screws should not exceed 2.2 in-lb (0.25 Nm).

Step 8 When you are ready to power up the switch, remove the safety flag and lockout devices from the PoE expansion module DC circuit and turn on the power to power up the module.

Running POST

When the switch powers on, it automatically initiates a POST. The POST runs a series of tests that verify that the switch functions properly and ensures that it is ready to install. To test the switch, follow these steps:

- [Applying Power to the Switch, page B-27](#)
- [Verify POST Results, page B-27](#)
- [Disconnect Power, page B-29](#)

Applying Power to the Switch

To apply power to a switch that is directly connected to a DC power source, locate the circuit breaker on the panel board that services the DC circuit, and switch the circuit breaker to the ON position.



Note For instructions on how to apply power to a switch that is connected to a power converter, see the [“Applying Power to the Power Converter” section on page B-61](#).

If you have installed a PoE expansion module (either IEM-3000-4PC or IEM-3000-4PC-4TC) to the switch, you must attach DC power directly to the expansion module. DC power can be either from site source DC (verify that source DC power meets the power input requirements of the expansion module) or from a separate DC-power supply (PWR-IE65W-PC-DC or PWR-IE65W-PC-AC). If your switch configuration consists of two PoE expansion modules, you must connect each expansion module to a separate power supply. For instructions on how to connect the DC-input power supply to the PoE expansion module, refer to the Cisco IE 3000 65 W DC-Input Power Supply Installation Note available on cisco.com. For instructions on how to connect the AC-input power supply to the PoE expansion module, refer to the Cisco IE 3000 65 W AC-Input Power Supply Installation Note available on cisco.com.



Note Both the AC-input and the DC-input power supplies can support only two ports configured as PoE+ ports. If you want to operate all four PoE expansion module ports as PoE+, you must connect the expansion module directly to the site’s source DC.

Verify POST Results

When you power on the switch, it automatically begins a POST. All LEDs are off for a few seconds, and then each LED is tested. One at a time, the System, Alarm, Setup, Pwr A, and Pwr B LEDs each briefly turns green, then red, and then go off. The System LED blinks green as the boot loader verifies the basic

functionality of the processing and memory hardware. Assuming all tests pass, the System LED continues to blink green as the Cisco IOS software image loads. If the POST fails, the System LED turns red.

**Note**

POST failures are usually fatal. Call Cisco Systems immediately if your switch does not pass POST. See the [“Obtaining Documentation, Obtaining Support, and Security Guidelines”](#) section on page viii.

Disconnect Power

After successfully running POST, follow these steps.

-
- | | |
|---------------|--|
| Step 1 | Turn off power to the switch. |
| Step 2 | Disconnect the cables. |
| Step 3 | Decide where you want to install the switch. |
-

Installing the Switch

These sections describes how to install the switch:

- [Installing the Switch on a DIN Rail](#)
- [Installing the Switch on a Wall](#)
- [Installing the Switch in a Rack](#)



Warning

This equipment is supplied as “open type” equipment. It must be mounted within an enclosure that is suitably designed for those specific environmental conditions that will be present and appropriately designed to prevent personal injury resulting from accessibility to live parts. The interior of the enclosure must be accessible only by the use of a tool.

The enclosure must meet IP 54 or NEMA type 4 minimum enclosure rating standards. Statement 1063



Warning

When used in a Class I, Division 2, hazardous location, this equipment must be mounted in a suitable enclosure with proper wiring method, for all power, input and output wiring, that complies with the governing electrical codes and in accordance with the authority having jurisdiction over Class I, Division 2 installations. Statement 1066



Caution

To prevent the switch from overheating, ensure these minimum clearances:

- Top and bottom: 4.13 in. (105 mm)
 - Exposed side (not connected to the module): 3.54 in. (90 mm)
 - Front: 2.56 in. (65 mm)
-

Installing the Switch on a DIN Rail

The switch ships with latches on the rear panel for a mounting on a DIN rail. See [Figure B-18](#).

Figure B-18 Cisco IE 3000 Switch Rear Panel

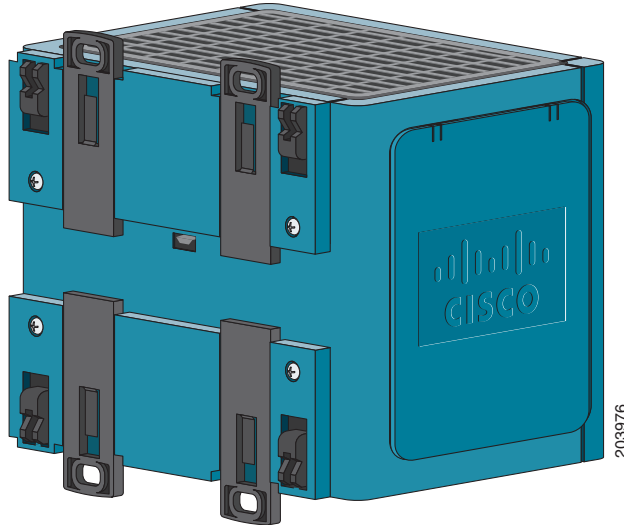

You can install the switch as a standalone device on the DIN rail or with the expansion modules already connected. You must connect the expansion modules to the switch before installing the switch on the DIN rail. To connect the modules to the switch, follow the steps described in the “[Adding Modules to the Switch](#)” section on page B-7.

The illustrations in this procedure show how to install the switch as a standalone device. The same steps can be used to install a switch with expansion modules on the DIN rail.

To attach the switch to a DIN rail, follow these steps.

- Step 1** Use a tool such as a flathead screw driver to press in the space next to the tab on each of the latches and turn the screw driver clockwise. See [Figure B-19](#).

Figure B-19 **Unlock the Switch Latch**

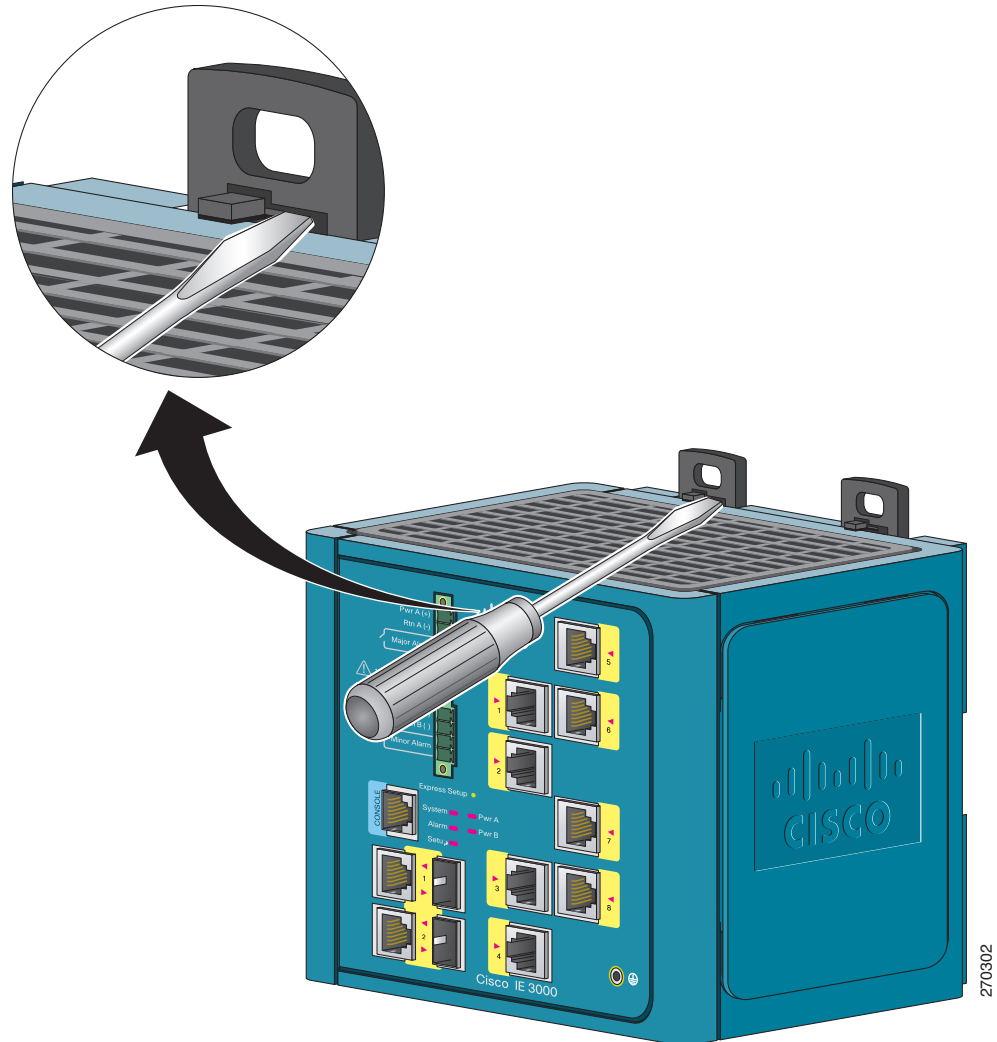

Step 2 Push the DIN rail latches out. See [Figure B-20](#).

Figure B-20 Pushing the DIN Rail Latches Out

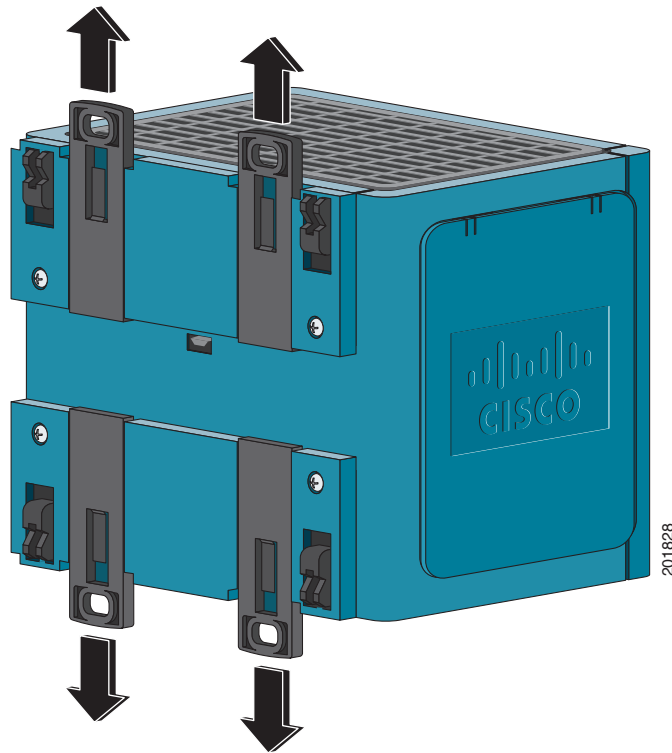

Step 3 Position the rear panel of the switch directly in front of the DIN rail, making sure that the DIN rail fits in the space between the two latches.

Step 4 Push the DIN rail latches in after the switch is over the DIN rail. See [Figure B-21](#).

Figure B-21 Pushing the DIN Rail Latches In

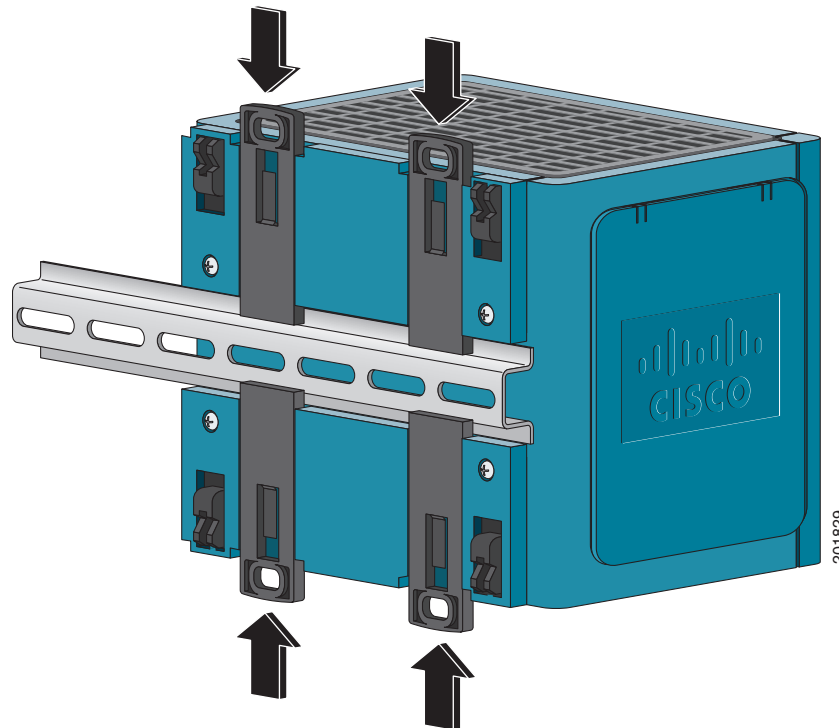

Note

If you are using a 15-mm DIN rail, rotate all of the feet (see [Figure B-21](#)) to the extended positions. Otherwise, rotate all of the feet to the recessed positions. [Figure B-22](#) shows the two DIN rails. You can use either the 7.5-mm or the 15-mm DIN rail.

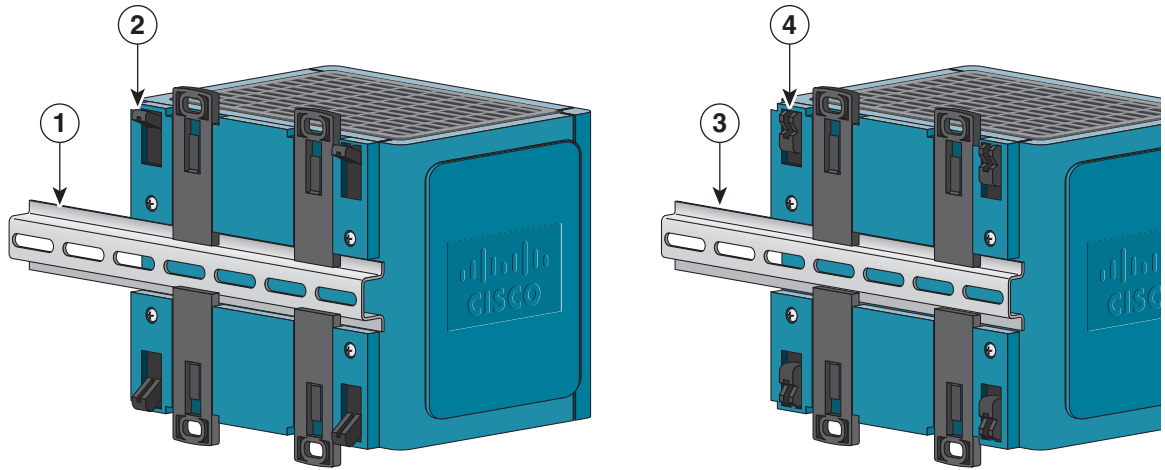
Figure B-22 Mounting the Switch on a DIN Rail in a Parallel Position

| | | | |
|----------|---------------------------|----------|---------------------------|
| 1 | 15-mm DIN rail | 3 | 7.5-mm DIN rail |
| 2 | Foot in extended position | 4 | Foot in recessed position |

After the switch is mounted on the DIN rail, connect the power and alarm wires, as described in the “[Connecting Power and Alarm Circuits](#)” section on page B-39.

**Note**

For instructions on how to remove the switch from a DIN rail, see the “[Removing the Switch from a DIN Rail or a Rack](#)” section on page B-38.

Installing the Switch on a Wall

To attach the switch to a wall or a panel, follow these steps.

**Warning**

Read the wall-mounting instructions carefully before beginning installation. Failure to use the correct hardware or to follow the correct procedures could result in a hazardous situation to people and damage to the system. Statement 378

Step 1 If the DIN rail latches are pushed out, push in the DIN rail latches. See [Figure B-23](#).

Figure B-23 Pushing the DIN Rail Latches In

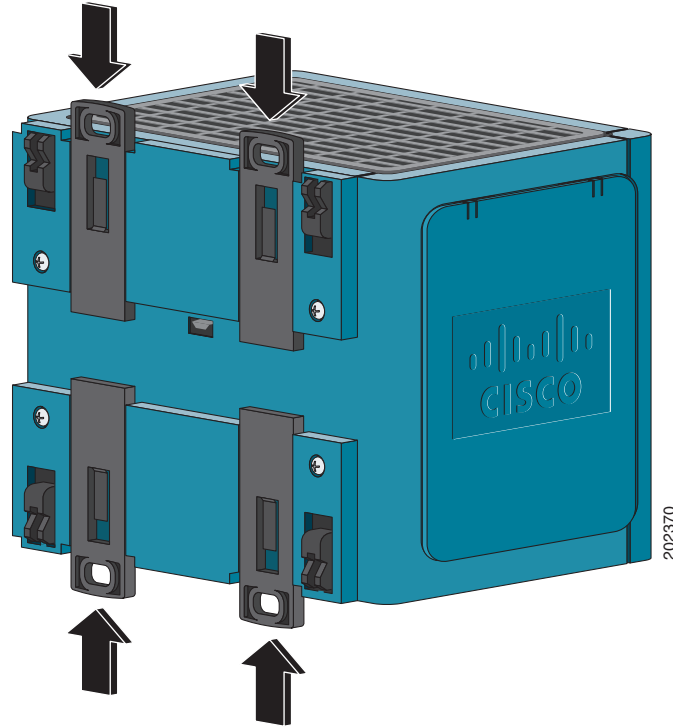

- Step 2** Rotate all feet to the recessed positions so that the switch can mount flat on the wall or panel. See [Figure B-22](#).
- Step 3** Position the rear panel of the switch against the wall or a panel in the desired location. See [Figure B-24](#).

Figure B-24 Mounting the Switch on the Wall

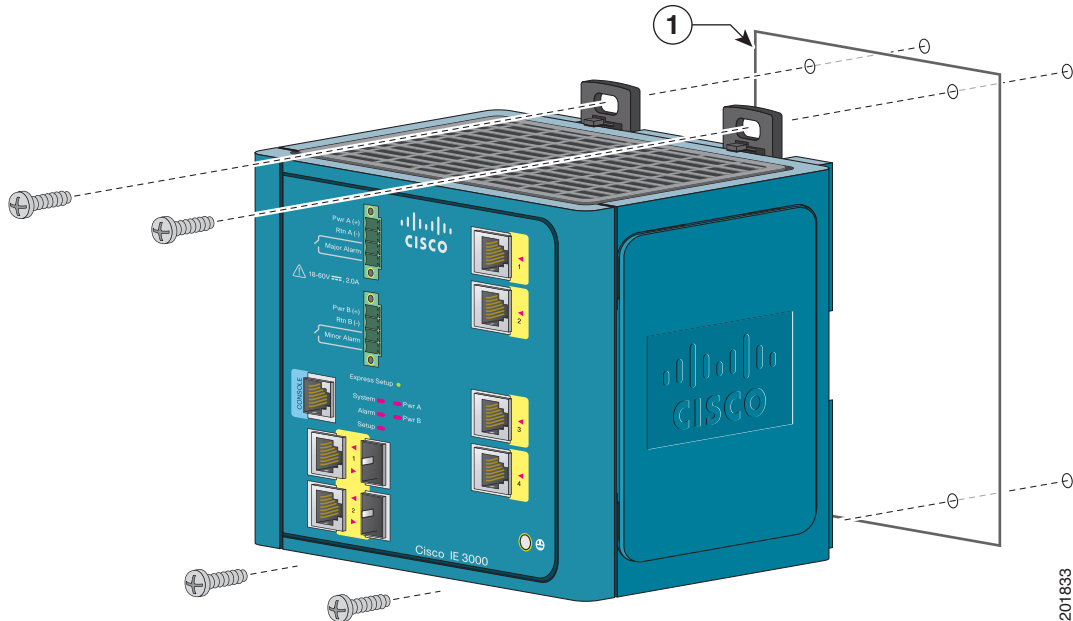

- Step 4** Place a number-10 screw that you provide through each DIN rail latch, and screw them into the wall.

| | |
|---|------|
| 1 | Wall |
|---|------|

After the switch is mounted on the wall or panel, connect the power and alarm wires, as described in the [“Connecting Power and Alarm Circuits”](#) section on page B-39.

Installing the Switch in a Rack

You can use an optional DIN rail adapter kit (available through Cisco, part number STK-RACKMNT-2955=) to mount the switch in a 19-inch rack. The rack-mounting kit comes with a DIN rail adapter and screws to attach the adapter to the rack. Ask your Cisco representative for details.

**Warning**

To prevent bodily injury when mounting or servicing this unit in a rack, you must take special precautions to ensure that the system remains stable. The following guidelines are provided to ensure your safety:

- This unit should be mounted at the bottom of the rack if it is the only unit in the rack.
- When mounting this unit in a partially filled rack, load the rack from the bottom to the top with the heaviest component at the bottom of the rack.
- If the rack is provided with stabilizing devices, install the stabilizers before mounting or servicing the unit in the rack. **Statement 1006**

**Note**

The 19-inch rack adapter is not intended for application in an industrial environment and therefore it will not meet the environmental performance specifications for the Cisco IE 3000 switch.

To install the switch in a rack, follow these steps:

- Step 1** Use the four Phillips machine screws to securely attach the brackets to the rack. See [Figure B-25](#).

Figure B-25 Installing the DIN Rail on the Rack

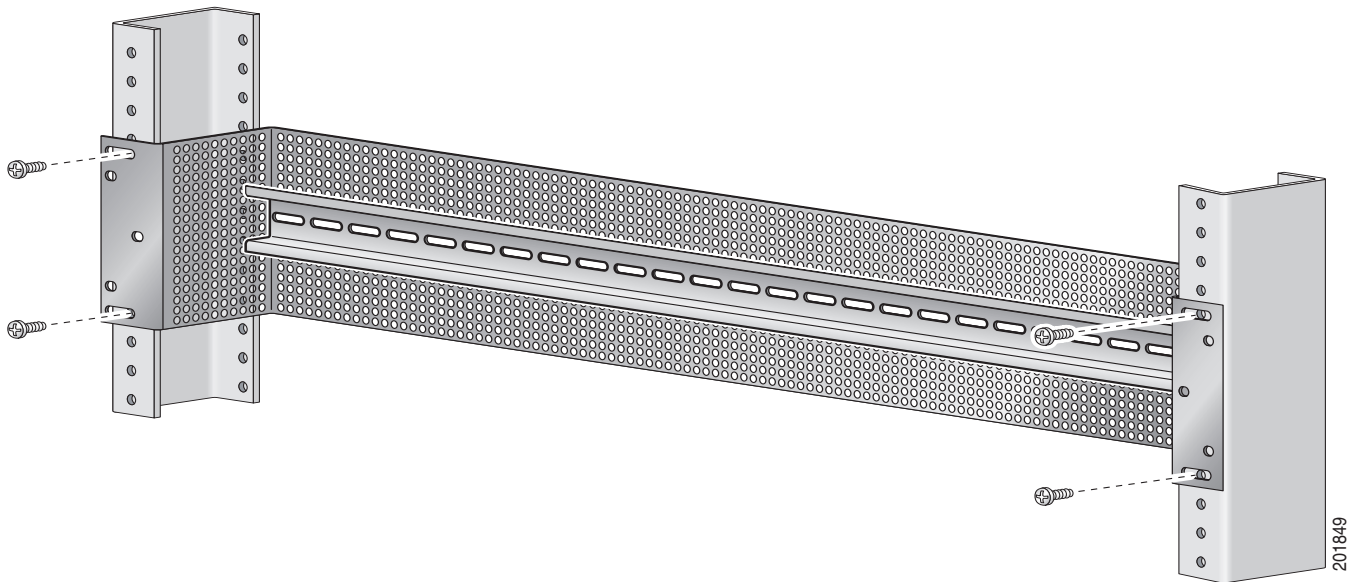

- Step 2** Follow the steps described in the “[Installing the Switch on a DIN Rail](#)” section on page B-30.

Figure B-26 *Installing the Switch on a Rack*

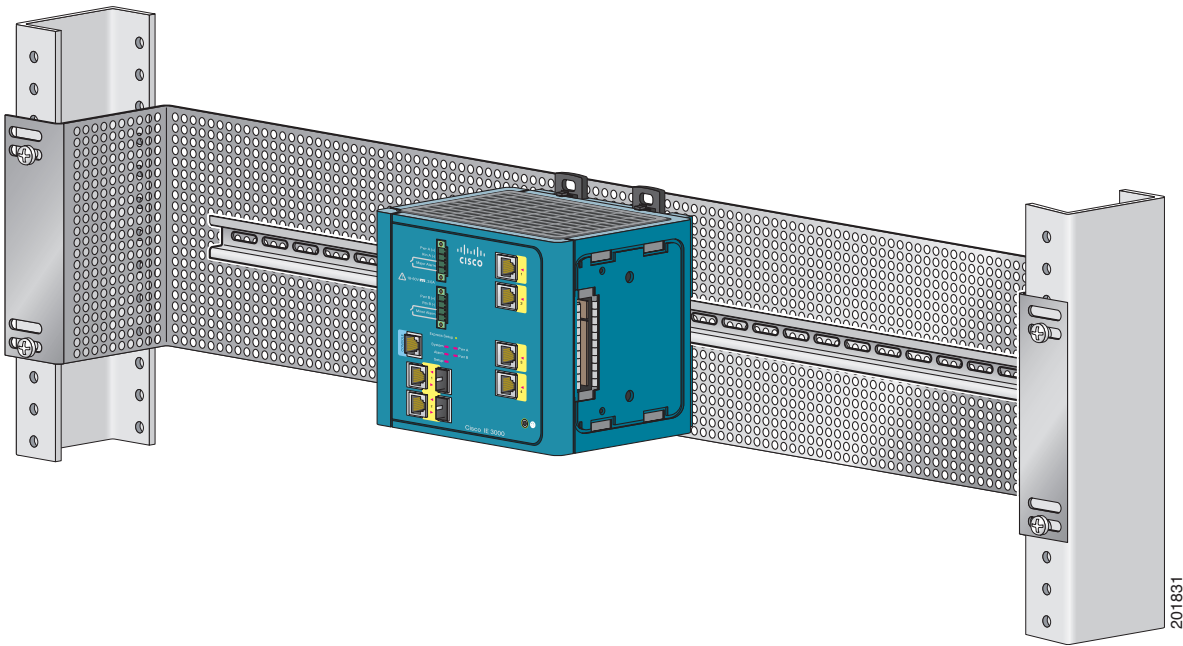

After the switch is mounted in the rack, connect the power and alarm wires, as described in the [“Connecting Power and Alarm Circuits”](#) section on page B-39.

For instructions on how to remove the switch from a rack, see the [“Removing the Switch from a DIN Rail or a Rack”](#) section on page B-38.

Removing the Switch from a DIN Rail or a Rack

To remove the switch from a DIN rail or a rack, follow these steps:

-
- Step 1** Ensure that power is removed from the switch, and disconnect all cables and connectors from the front panel of the switch.
 - Step 2** Use a tool such as a flathead screw driver to press in the space next to the tab on each of the latches and turn the screw driver clockwise. See [Figure B-19](#).
 - Step 3** Push the DIN rail latches at the top of the switch up and the latches at the bottom of the switch down. Pull the switch out, and release the switch from the DIN rail. See [Figure B-27](#).

Figure B-27 Removing the Switch from the DIN Rail

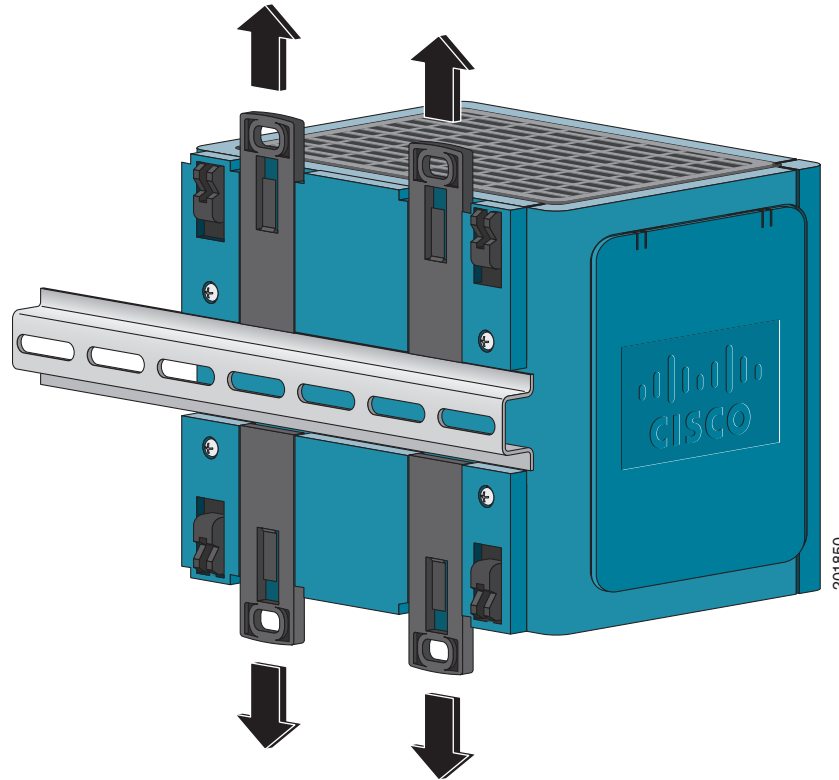

Step 4 Remove the switch from the DIN rail.

Connecting Power and Alarm Circuits

After the switch is installed, you are ready to connect the DC power and alarm relays.

- [Information about the Sealed Relay Device, page B-40](#)
- [Wiring the Protective Ground and DC Power, page B-40](#)
- [Wiring the External Alarms, page B-41](#)

Information about the Sealed Relay Device

We recommend that you periodically inspect the sealed relay device. Inspect the device for any degradation of materials. If any degradation is found, replace the *complete* product, not only the sealed device. Following is some information about the sealed relay device:



Warning

Exposure to some chemicals could degrade the sealing properties of materials used in the sealed relay device. Statment 381

Sealed Device: Relay Model AGN200A03, manufactured by Matsushita Electric Works

Relay cover: manufacturer of plastic material, Nippon Oil Corporation
 Designation of plastic material: type FC-100
 Generic name of plastic material: liquid-crystal polymer

Relay body: manufacturer of plastic material, Ueno Fine Chemicals Industry Ltd.
 Designation of plastic material: type 2125G
 Generic name of plastic material: liquid-crystal polymer

Relay Epoxy: manufacturer of plastic material, Resinous Kasei Co. Ltd.
 Designation of material: type A-2500BK
 Generic name of plastic material: epoxy resin

Sealed Device: Relay Model B4GA003Z, manufactured by Fujitsu Takamisawa Electric Company Ltd.

Relay cover: manufacturer of plastic material, Sumitomo Chemical Co. Ltd.
 Designation of plastic material: type E4009
 Generic name of plastic material: liquid-crystal polymer

Relay body: manufacture of plastic material, Sumitomo Chemical Co. Ltd.
 Designation of plastic material: type E6807LHF
 Generic Name of plastic material: liquid-crystal polymer

Relay Epoxy: manufacture of material, Sumitomo Bakelite Co. Ltd.
 Designation of material: type SUMIMAC ECR-9750K2
 Generic name of plastic material: epoxy resin

Wiring the Protective Ground and DC Power

For instructions on grounding the switch and connecting the DC power, see the [“Connecting the Protective Ground and DC Power” section on page B-17.](#)

For instructions on using a power converter for DC power, see the [“Connecting the Switch to the Power Converter” section on page B-52.](#)

Wiring the External Alarms

The alarm relays on the switch are normally open. To connect an external alarm device to the relays, you must connect two relay contact wires to complete an electrical circuit. Because each external alarm device requires two connections to a relay, the switch supports a maximum of two external alarm devices. This procedure is optional.



Warning

Explosion Hazard—Do not connect or disconnect wiring while the field-side power is on; an electrical arc can occur. This could cause an explosion in hazardous location installations. Be sure that power is removed or that the area is nonhazardous before proceeding. Statement 1081



Caution

The input voltage source of the alarm circuits must be an isolated source and limited to less than or equal to 24 VDC, 1 A.



Note

Wire connections to the power and relay connector, must be UL- and CSA-rated, style 1007 or 1569 twisted-pair copper appliance wiring material (AWM) wire (such as Belden part number 9318).

To wire the switch to an external alarm device, follow these steps:

- Step 1** Measure two strands of twisted-pair wire (18-to-20 AWG) long enough to connect to the external alarm device.
- Step 2** Use a wire stripper to remove the casing from both ends of each wire to 0.25 inch (6.3 mm) \pm 0.02 inch (0.5 mm). Do not strip more than 0.27 inch (6.8 mm) of insulation from the wires. Stripping more than the recommended amount of wire can leave exposed wire from the power and relay connector after installation.
- Step 3** Insert the exposed wires for the external alarm device into the two connections labeled A. See [Figure B-28](#).

Figure B-28 Inserting Relay Wires into the Power and Relay Connector

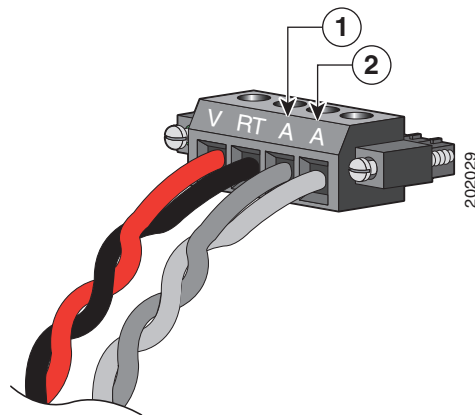

| | | | |
|----------|--|----------|--|
| 1 | External device, relay wire A connection 1 | 2 | External device, relay wire A connection 2 |
|----------|--|----------|--|

- Step 4** Use a ratcheting torque flathead screwdriver to torque the power and relay connector captive screw (above the installed wire leads) to 2.2 in-lb (0.25 Nm). See [Figure B-29](#) for details.

**Caution**

Do not over-torque the power and relay connector captive screws. The torque should not exceed 2.2 in-lb (0.25 Nm).

Figure B-29 Torquing the Power and Relay Connector Captive Screws

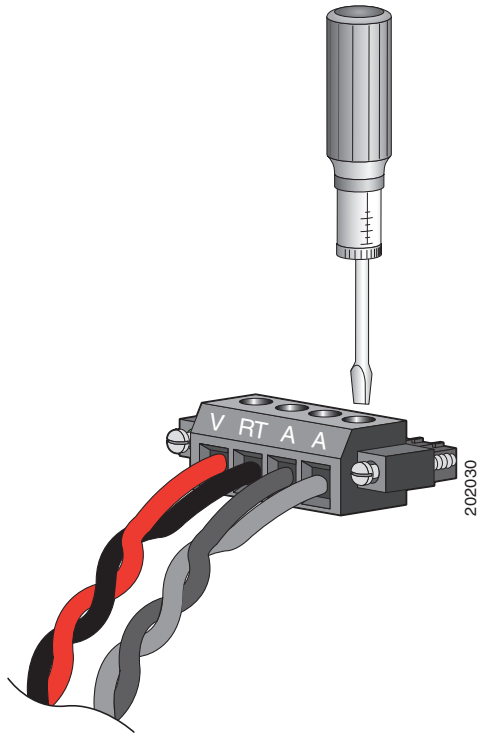

- Step 5** Repeat [Step 1](#) through [Step 4](#) to insert the input and output wires of an additional external alarm device into the second power and relay connector.

Figure B-30 shows the completed wiring for two power supplies and two external alarm devices.

Figure B-30 Completed Connections for Two External Alarm Devices on the Power and Relay Connector

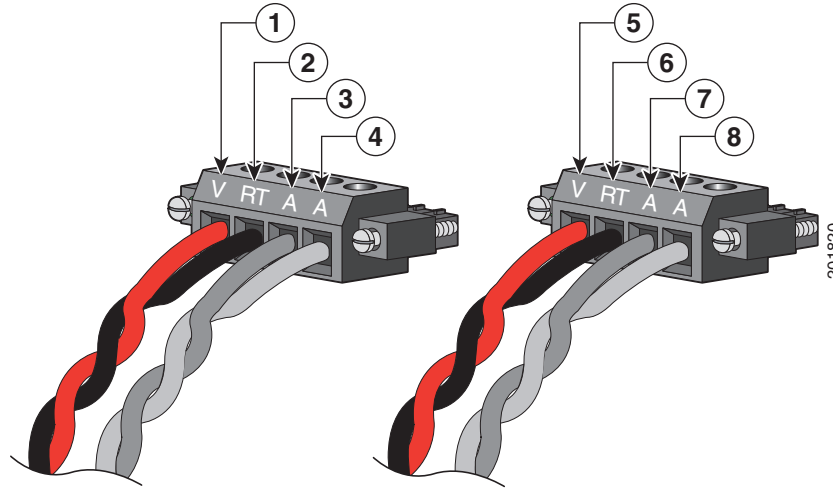

| | | | |
|----------|--|----------|--|
| 1 | Power source A positive connection | 5 | Power source B positive connection |
| 2 | Power source A return connection | 6 | Power source B return connection |
| 3 | External device 1, relay wire major alarm connection | 7 | External device 2, relay wire minor alarm connection |
| 4 | External device 1, relay wire major alarm connection | 8 | External device 2, relay wire minor alarm connection |

If your power source is -48 VDC, this table describes the wiring connections for Figure B-30.

| | | | |
|----------|--|----------|--|
| 1 | Power source A return connection | 5 | Power source B return connection |
| 2 | Power source A -48 VDC connection | 6 | Power source B -48 VDC connection |
| 3 | External device 1, relay wire major alarm connection | 7 | External device 2, relay wire minor alarm connection |
| 4 | External device 1, relay wire major alarm connection | 8 | External device 2, relay wire minor alarm connection |

See the “Attach the Power and Relay Connector to the Switch” section on page B-25 for instructions on how to connect the power and relay connector to the front panel.

Connecting Destination Ports

These section provide more information about connecting to the destination ports:

- [Connecting to 10/100 and 10/100/1000 Ports, page B-44](#)
- [Installing and Removing SFP Transceivers, page B-45](#)
- [Connecting to SFP Transceivers, page B-48](#)
- [Connecting to a Dual-Purpose Port, page B-49](#)
- [Connecting to 100BASE-FX Ports, page B-51](#)
- [Connecting to a PoE Port, page B-52](#)

Connecting to 10/100 and 10/100/1000 Ports

The switch 10/100/1000 ports automatically configure themselves to operate at the speed of attached devices. If the attached ports do not support autonegotiation, you can explicitly set the speed and duplex parameters. Connecting devices that do not autonegotiate or that have their speed and duplex parameters manually set can reduce performance or result in no linkage.



Warning

Do not connect or disconnect cables to the ports while power is applied to the switch or any device on the network because an electrical arc can occur. This could cause an explosion in hazardous location installations. Be sure that power is removed from the switch and cannot be accidentally be turned on, or verify that the area is nonhazardous before proceeding. Statement 1070

To maximize performance, choose one of these methods for configuring the Ethernet ports:

- Let the ports autonegotiate both speed and duplex.
- Set the port speed and duplex parameters on both ends of the connection.

Follow these steps to connect to 10BASE-T, 100BASE-TX or 1000BASE-T devices:



Caution

To prevent electrostatic-discharge (ESD) damage, follow your normal board and component handling procedures.

Step 1

When connecting to workstations, servers, routers, and Cisco IP Phones, connect a straight-through cable to an RJ-45 connector on the front panel. See [Figure B-31](#).

When connecting to 1000BASE-T-compatible devices, use a twisted four-pair, Category 5 or higher cable.

The auto-MDIX feature is enabled by default. For configuration information for this feature, see the switch software configuration guide or the switch command reference.

Figure B-31 Connecting to an Ethernet Port

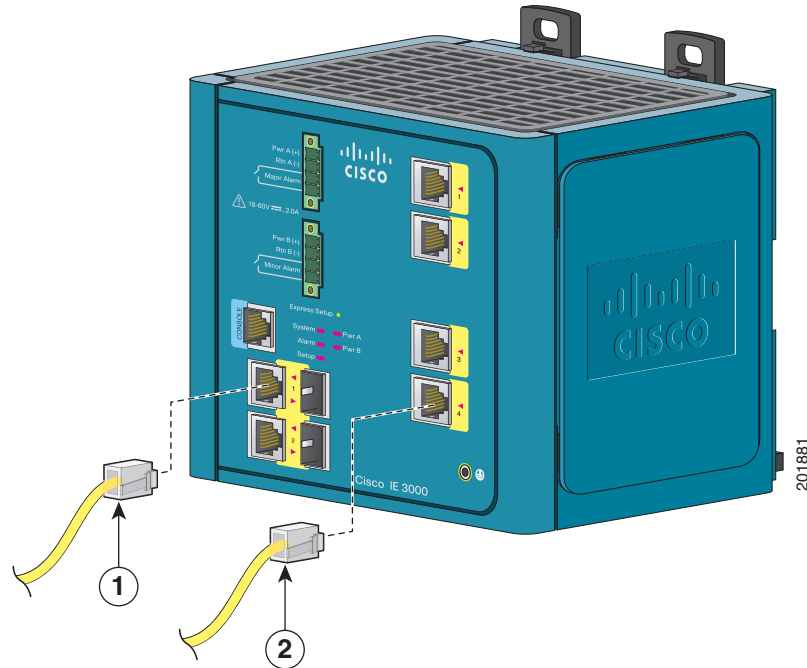

| | | | |
|---|------------------|---|--------------|
| 1 | 10/100/1000 port | 2 | 10/100 ports |
|---|------------------|---|--------------|

- Step 2** Connect the other end of the cable to an RJ-45 connector on the other device. The port LED turns on when both the switch and the connected device have established a link.
- The port LED is amber while Spanning Tree Protocol (STP) discovers the topology and searches for loops. This can take up to 30 seconds, and then the port LED turns green. If the port LED does not turn on:
- The device at the other end might not be turned on.
 - There might be a cable problem or a problem with the adapter installed in the attached device. See [Chapter 3, “Troubleshooting,”](#) for solutions to cabling problems.
- Step 3** Reconfigure and reboot the connected device if necessary.
- Step 4** Repeat Steps 1 through 3 to connect each device.

Installing and Removing SFP Transceivers

These sections describe how to install and remove SFP transceivers. SFP transceivers are inserted into SFP transceiver sockets on the front of the switch or the Cisco IEM-3000-4SM or Cisco IEM-3000-8SM expansion modules. These field-replaceable modules provide the optical interfaces, send (TX) and receive (RX).

You can populate the switch or expansion module ports with a combination of rugged SFP transceiver types. Not all SFP transceiver types are supported. See the Cisco IE 3000 release notes for the list of supported SFP transceiver. SFP transceiver types must match on both ends of the network cable and the length of the network cable must not exceed the stipulated cable length for reliable communications. Supported cable lengths for the SFP transceiver types are listed in [Table C-1](#) on [page C-6](#).

**Caution**

When you use commercial SFP transceiver types such as CWDM and 1000BX-U/D in the IE-3000-4TC or IE-3000-8TC S switch SFP ports, reduce the maximum operating temperature by 59°F (15°C). The minimum operating temperature is 32°F (0°C). The IEM-3000-4SM or the IEM-3000-8SM expansion module SFP ports do not operate at 1Gbps.

For detailed instructions on installing, removing, and cabling the SFP module, see the SFP transceiver documentation on cisco.com.

Installing SFP Transceivers into Module Ports

**Note**

This procedure is applicable to SFP ports on either the switches or on the expansion modules.

[Figure B-32](#) shows an SFP transceiver that has a bale-clasp latch.

**Caution**

We strongly recommend that you do not install or remove the SFP transceiver with fiber-optic cables attached to it because of the potential damage to the cables, the cable connector, or the optical interfaces in the SFP transceiver. Disconnect all cables before removing or installing an SFP transceiver.

Removing and installing an SFP transceiver can shorten its useful life. Do not remove and insert SFP transceivers more often than is absolutely necessary.

Figure B-32 SFP Transceiver with a Bale-Clasp Latch

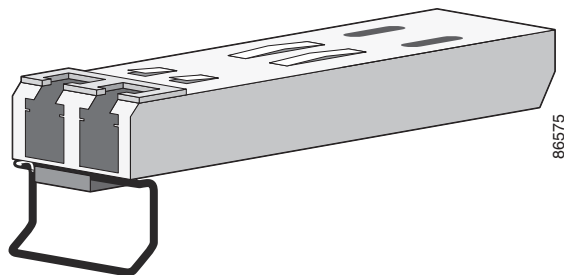

To insert an SFP module into the SFP module slot, follow these steps:

- Step 1** Attach an ESD-preventive wrist strap to your wrist and to a grounded bare metal surface.
- Step 2** Find the send (TX) and receive (RX) markings that identify the correct side of the SFP transceiver.
On some SFP transceivers, the send and receive (TX and RX) markings might be replaced by arrows that show the direction of the connection, either send or receive (TX or RX).
- Step 3** Align the SFP transceiver sideways in front of the SFP socket opening.

- Step 4** Slide the SFP transceiver into the socket until you feel the transceiver connector latch into place. See [Figure B-33](#).

Figure B-33 Installing an SFP Transceiver into an SFP Module Socket

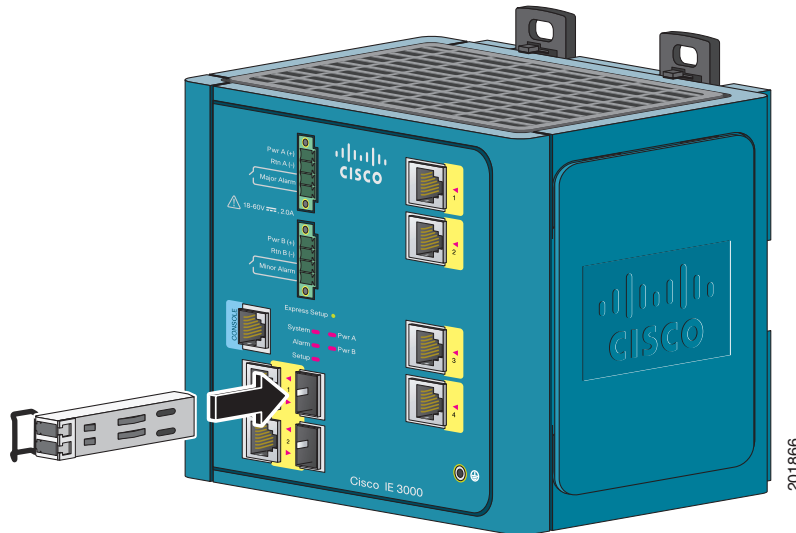

Caution

Do not remove the dust plugs from the SFP module port or the rubber caps from the fiber-optic cable until you are ready to connect the cable. The plugs and caps protect the SFP module ports and cables from contamination and ambient light.

- Step 5** Using your thumb, press firmly on the SFP transceiver to ensure that the SFP is properly latched in the port.
- Step 6** When you are ready to install the network cable, remove the dust plugs from both the cable and the SFP transceiver and store them away for future use. Insert the LC cable connector into the SFP transceiver.

Removing SFP Transceivers from Module Ports

To remove an SFP transceiver from a module port, follow these steps:

- Step 1** Attach an ESD-preventive wrist strap to your wrist and to a grounded bare metal surface.
- Step 2** Disconnect the LC from the SFP module.
- Step 3** Insert a dust plug into the optical ports of the SFP module to keep the optical interfaces clean.
- Step 4** Unlock and remove the SFP module. See [Figure B-34](#).

If the SFP transceiver has a bale-clasp latch, pull the bale out and down to eject the transceiver. If the bale-clasp latch is obstructed and you cannot use your index finger to open it, use a small, flat-blade screwdriver or other long, narrow instrument to open the bale-clasp latch.

Figure B-34 Removing a Bale-Clasp Latch SFP Transceiver by Using a Flat-Blade Screwdriver

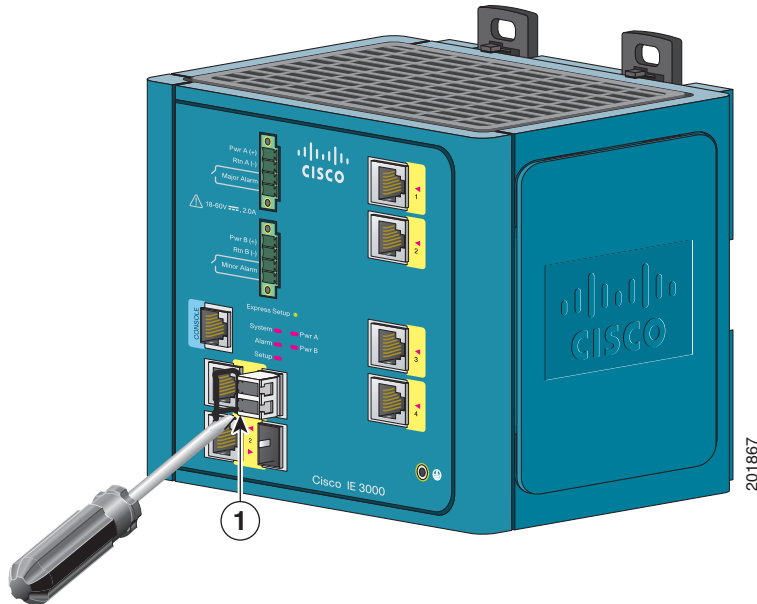

| | |
|----------|------------|
| 1 | Bale clasp |
|----------|------------|

- Step 5** Grasp the SFP Transceiver between your thumb and index finger, and carefully remove it from the module port.
- Step 6** Place the removed SFP transceiver in an antistatic bag or other protective environment.

Connecting to SFP Transceivers

This section describes how to connect to a fiber-optic SFP port. To connect to an RJ-45 Gigabit Ethernet port instead of a fiber-optic port, see the [“Connecting to a Dual-Purpose Port”](#) section on page B-49.

For instructions on how to install or remove an SFP transceiver, see the [“Installing and Removing SFP Transceivers”](#) section on page B-45.

Follow these steps to connect a fiber-optic cable to an SFP transceiver:



Warning

Class 1 laser product. Statement 1008



Caution

Do not remove the rubber plugs from the SFP transceiver port or the rubber caps from the fiber-optic cable until you are ready to connect the cable. The plugs and caps protect the SFP transceiver optical bores and the cables from contamination.

Before connecting to the SFP transceiver, be sure that you understand the port and cabling stipulations in the [“Preparing for Installation”](#) section on page B-1. See Appendix C, [“Cable and Connectors,”](#) for information about the LC connector on the SFP transceiver.

- Step 1** Remove the rubber plugs from the SFP optical bores and fiber-optic cable, and store them for future use.
- Step 2** Insert one end of the fiber-optic cable into the SFP transceiver. See [Figure B-35](#).

Figure B-35 Connecting to a Fiber-Optic SFP Transceiver Port

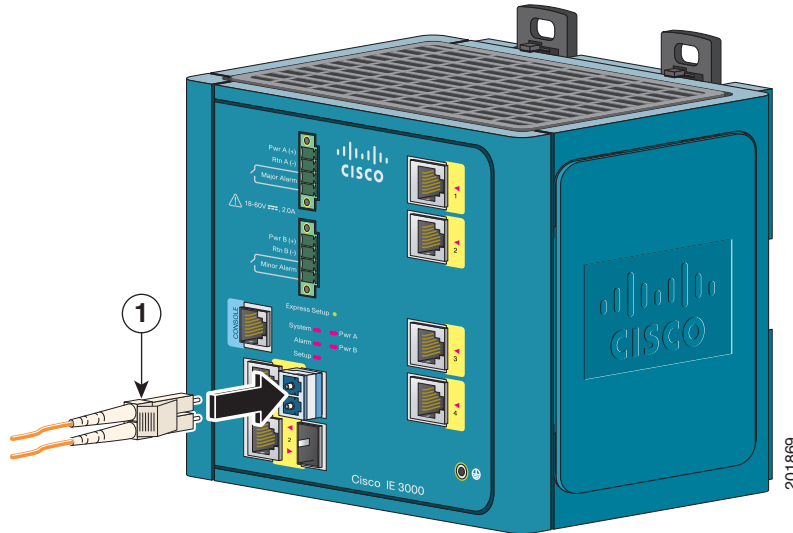

1 LC connector

- Step 3** Insert the other cable end into a fiber-optic receptacle on a target device.
- Step 4** Observe the port status LED.
- The LED turns green when the switch and the target device have an established link.
- The LED turns amber while the STP discovers the network topology and searches for loops. This process takes about 30 seconds, and then the port LED turns green.
- If the LED is off, the target device might not be turned on, there might be a cable problem, or there might be a problem with the adapter installed in the target device. See [Chapter 3, “Troubleshooting,”](#) for solutions to cabling problems.
- Step 5** If necessary, reconfigure and restart the switch or the target device.

Connecting to a Dual-Purpose Port

The dual-purpose port is a single port with two interfaces, one for an RJ-45 cable and another for an SFP module. Only one interface can be active at a time. If both interfaces are connected, the SFP module has priority. For more information about dual-purpose ports, see the [“Dual-Purpose Ports”](#) section on [page 1-8](#).



Class 1 laser product. Statement 1008

**Caution**

Do not remove the rubber plugs from the SFP module port or the rubber caps from the fiber-optic cable until you are ready to connect the cable. The plugs and caps protect the SFP module ports and cables from contamination and ambient light.

Before connecting to the SFP module, be sure that you understand the port and cabling stipulations in the “[Preparing for Installation](#)” section on page B-1. See [Appendix C, “Cable and Connectors,”](#) for information about the LC on the SFP module.

To connect to a dual-purpose port, follow these steps:

- Step 1** Connect an RJ-45 connector to the 10/100/1000 port, or install an SFP module into the SFP module slot, and connect a cable to the SFP module port. See [Figure B-36](#).

For more information about RJ-45 connections, SFP modules, and optical connections, see the “[Connecting to 10/100 and 10/100/1000 Ports](#)” section on page B-44, the “[Installing and Removing SFP Transceivers](#)” section on page B-45, and the “[Connecting to SFP Transceivers](#)” section on page B-48.

Figure B-36 Connecting to a Dual-Purpose Port

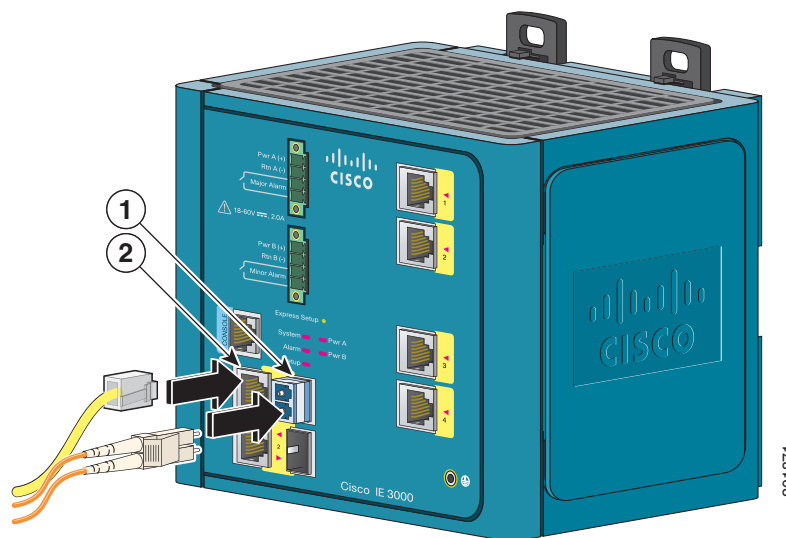

| | | | |
|----------|--------------|----------|-----------------|
| 1 | LC connector | 2 | RJ-45 connector |
|----------|--------------|----------|-----------------|

- Step 2** Connect the other end of the cable to the other device.

By default, the switch detects whether an RJ-45 connector or SFP module is connected to a dual-purpose port and configures the port accordingly. You can change this setting and configure the port to recognize only an RJ-45 connector or only an SFP module by using the **media type** interface configuration command. For more information, see the switch command reference.

Connecting to 100BASE-FX Ports

Follow these steps to connect a fiber-optic cable to an Cisco IEM-3000-8FM expansion module:

Warning

Class 1 laser product. Statement 1008



Caution

Do not remove the rubber plugs from the SFF module port or the rubber caps from the fiber-optic cable until you are ready to connect the cable. The plugs and caps protect the SFF module ports and cables from contamination and ambient light.

Before connecting to the SFF module, be sure that you understand the port and cabling stipulations in the [“Preparing for Installation” section on page B-1](#). See the [“Cable and Adapter Specifications” section on page C-5](#) for information about the LC connector on the SFP module.

- Step 1** Remove the rubber plugs from the module port and fiber-optic cable, and store them for future use.
- Step 2** Insert one end of the fiber-optic cable into the SFP module port. See [Figure B-35](#).

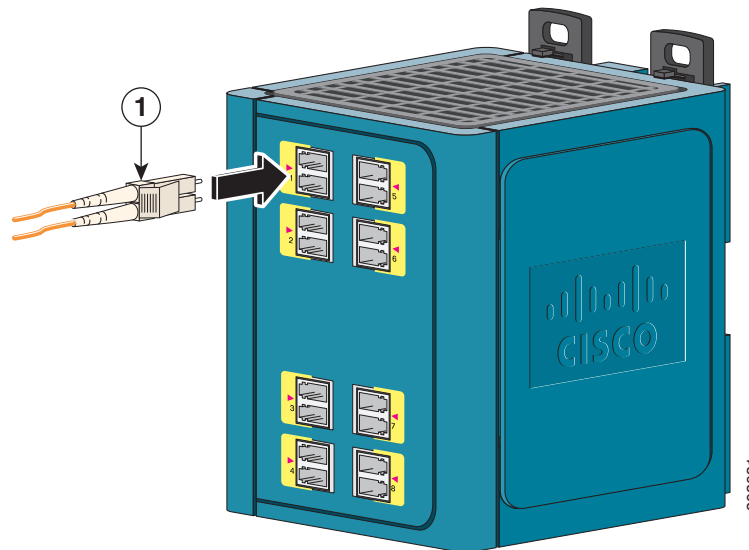
Figure B-37 Connecting to a Fiber-Optic SFP Module Port



| | |
|----------|--------------|
| 1 | LC connector |
|----------|--------------|

- Step 3** Insert the other cable end into a fiber-optic receptacle on a target device.
- Step 4** Observe the port status LED.

The LED turns green when the switch and the target device have an established link.

The LED turns amber while the STP discovers the network topology and searches for loops. This process takes about 30 seconds, and then the port LED turns green.

If an LED is off, the target device might not be turned on, there might be a cable problem, or there might be a problem with the adapter installed in the target device. See [Chapter 3, “Troubleshooting,”](#) for solutions to cabling problems.

Step 5 If necessary, reconfigure and restart the switch or target device.

Connecting to a PoE Port

Two expansion modules, the IEM-3000-4PC and the IEM-3000-4PC-4TC, provide 10/100BASE-T ports with PoE capability. The IEM-3000-4PC expansion module provides four PoE ports, or the four ports can be used as two PoE+ ports and two non-PoE ports. The IEM-3000-4PC-4TC expansion module provides four PoE ports and four non-PoE ports or the eight ports can be used as two PoE+ ports and six non-PoE ports. The PoE expansion modules each require a separate power supply to operate.



Note

Both the AC-input and the DC-input power supplies can support only two ports configured as PoE+ ports. If you want to operate all four PoE expansion module ports as PoE+, you must connect the expansion module directly to the site's source DC.

The expansion module PoE ports support either the IEEE 802.3af standard (PoE) which provides up to 15.4 W of power per port (4 ports total) or the IEEE 802.3at standard (PoE+) which provides up to 30 W of power per port (2 ports total)

Connecting the Switch to the Power Converter

The Cisco IE 3000 switch can be used with an optional AC/DC power converter (PWR-IE3000-AC).

These sections describe the steps required to connect the switch to a power converter:

- [Attaching the Power Converter to the Switch, page B-52](#)
- [Installing the Power Converter on a DIN Rail, Wall, or Rack Adapter, page B-55](#)
- [Connecting the DC Power Clip, page B-55](#)
- [Connecting the Power Converter to an AC Power Source, page B-56](#)
- [Connecting the Power Converter to a DC Power Source, page B-59](#)
- [Applying Power to the Power Converter, page B-61](#)

Attaching the Power Converter to the Switch

Follow these directions to connect the power converter to the switch:



Warning

Explosion Hazard—Do not connect or disconnect wiring while the field-side power is on; an electrical arc can occur. This could cause an explosion in hazardous location installations. Be sure that power is removed or that the area is nonhazardous before proceeding. Statement 1081

- Step 1** Remove the left side panel of the switch by firmly grasping both sides of it in the middle and pulling it outward. If necessary, use a screwdriver to open the side panel. See [Figure B-38](#).

Figure B-38 Opening the Left Side Panel of the Switch

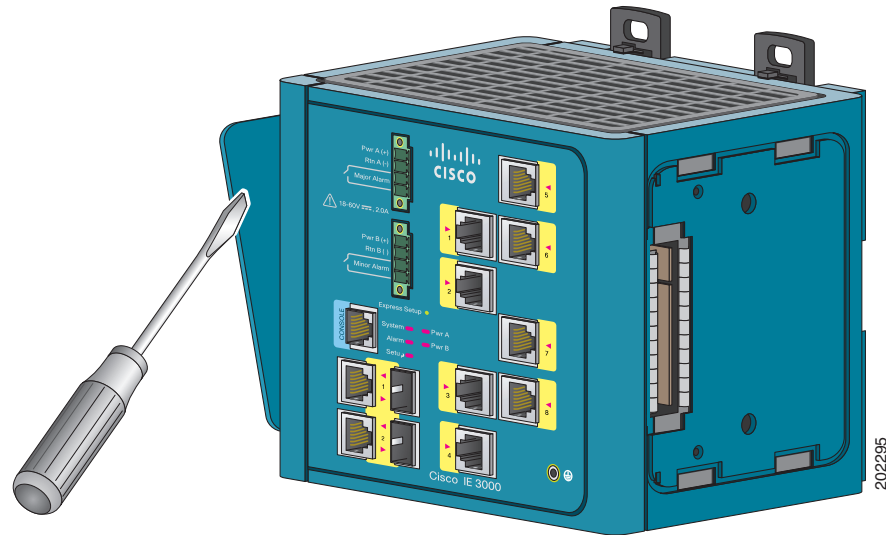

- Step 2** Push the upper modules latches (at the top of the switch and the power converter) up and the lower module latches (at the bottom of the switch and the power converter) down. See [Figure B-39](#).

Figure B-39 Pushing the Module Latches Up and Positioning the Hardware

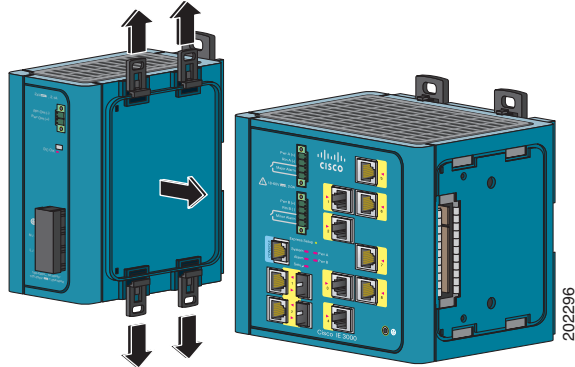

- Step 3** Put the two modules together so that the power module fits in the switch recess.
- Step 4** Push the upper module latches down and the lower module latches up to secure the power converter to the switch. See [Figure B-40](#).

Figure B-40 Pushing the Latches In

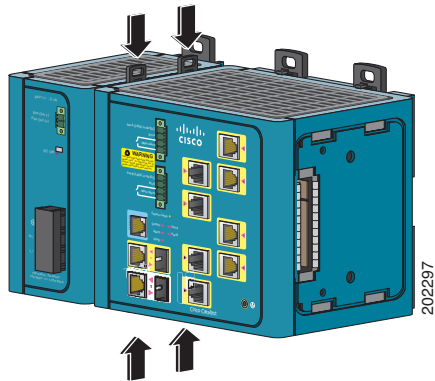

Installing the Power Converter on a DIN Rail, Wall, or Rack Adapter

You install the power converter on a DIN rail, wall, or rack as you would a switch module. You should first attach the power converter to the switch and then install the entire switch assembly on the DIN rail, wall, or rack adapter. For more information, see the [“Attaching the Power Converter to the Switch” section on page B-52](#), the [“Installing the Switch on a DIN Rail” section on page B-30](#), the [“Installing the Switch on a Wall” section on page B-34](#), or the [“Installing the Switch in a Rack” section on page B-36](#).

**Warning**

This equipment is supplied as “open type” equipment. It must be mounted within an enclosure that is suitably designed for those specific environmental conditions that will be present and appropriately designed to prevent personal injury resulting from accessibility to live parts. The interior of the enclosure must be accessible only by the use of a tool.

The enclosure must meet IP 54 or NEMA type 4 minimum enclosure rating standards. Statement 1063

**Caution**

To prevent the switch assemble from overheating, there must be a minimum of 3 inches (76.19 mm) between any other device and the top, bottom, or sides of the switch assembly.

Connecting the DC Power Clip

The DC power clip is a prewired cable that connects DC power from the power converter to the switch module. Because the power clip uses the Pwr A connector, you cannot use the alarm connections on that connector.

Follow these steps to connect DC power from the power converter to the switch module.

-
- Step 1** Locate the DC power clip in the power converter accessory kit.
- Step 2** Position the power clip so that the two-pin connector is over the power converter and the four-pin connector is over the switch Pwr A connector, and then slide the power clip into these two connectors. See [Figure B-41](#).

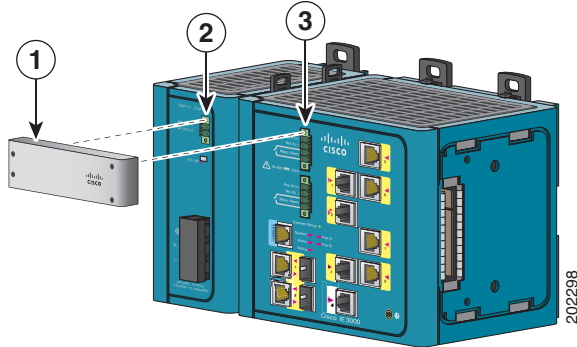
Figure B-41 Connecting Wires to the Power Converter DC Output Terminal Block

| | | | |
|----------|--|----------|----------------------------------|
| 1 | DC power clip | 3 | Four-pin connector on the switch |
| 2 | Two-pin connector on the power converter | | |

Step 3 Use a ratcheting torque flathead screwdriver to tighten the captive screw to 2.2 in-lb (0.25 Nm).

**Caution**

Do not over-torque the power and relay connector captive screws. The torque should not exceed 2.2 in-lb (0.25 Nm).

Connecting the Power Converter to an AC Power Source

These sections describe the steps required to connect the power converter to an AC power source:

- [Preparing the AC Power Cord, page B-56](#)
- [Connecting the AC Power Cord to the Power Converter, page B-57](#)

Preparing the AC Power Cord

To connect the power converter to an AC power source, you need an AC power cord. Power cord connector types and standards vary by country. Power-cord wiring color codes also vary by country. You must have a qualified electrician select, prepare, and install the appropriate power cord to the power supply.

**Note**

Use copper conductors only, rated at a minimum temperature of 167°F (75°C).

Connecting the AC Power Cord to the Power Converter

The following instructions are provided for a qualified electrician to attach the AC power cord to the power supply.



Caution

AC power sources must be dedicated AC branch circuits. Each branch circuit must be protected by a dedicated two-pole circuit breaker.



Caution

Do not insert the cord into the AC outlet until you finish wiring the line, neutral, and ground connections.

To attach the AC power cord to the power supply terminal block, follow these steps:

- Step 1** Remove the plastic cover from the input power terminals and set it aside. See [Figure B-42](#).

Figure B-42 AC/DC Power Input Terminal Block

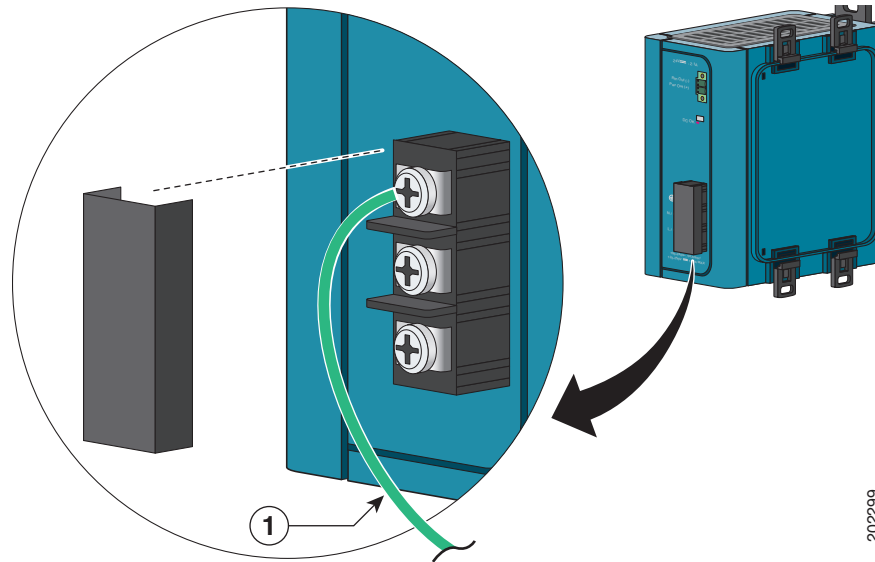

| | |
|----------|-------------|
| 1 | Ground wire |
|----------|-------------|

- Step 2** Insert the exposed ground wire lead into the power converter ground wire connection. Make sure that only wire *with insulation* extends from the connector. See [Figure B-43](#).

Figure B-43 Connecting AC Power to the Power Converter

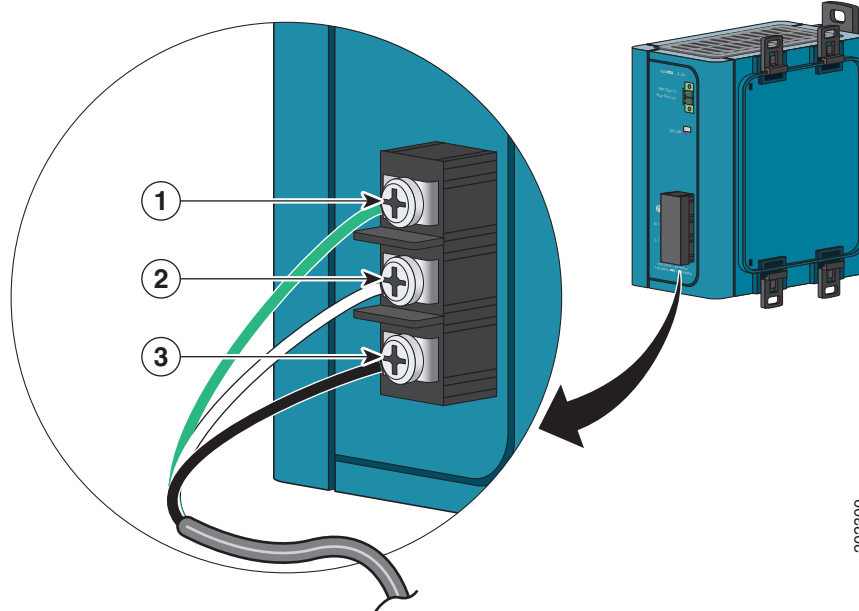

202300

| | | | |
|----------|------------|----------|---------|
| 1 | Ground | 3 | AC line |
| 2 | AC neutral | | |

Step 3 Tighten the ground wire terminal block screw.



Note The torque should not exceed 2.2 in-lb (0.25 Nm).

Step 4 Insert the line and neutral wire leads into the terminal block line and neutral connections. See [Figure B-43](#). Make sure that you cannot see any wire lead. Ensure that only wire *with insulation* extends from the connectors.

Step 5 Tighten the line and neutral terminal block screws.



Note The torque should not exceed 2.2 in-lb (0.25 Nm).

Step 6 Replace the plastic cover over the terminal block.

Step 7 Connect the other end of the AC power cord to the AC outlet.

Connecting the Power Converter to a DC Power Source

You can also connect the power converter to a DC power source. The power converter adapts the power source voltage to the 24 VDC that the switch requires.

Follow these steps to connect the power converter to a DC power source.

**Note**

Use copper conductors only, rated at a minimum temperature of 167°F (75°C).

**Warning**

Use twisted-pair supply wires suitable for 86°F (30°C) above surrounding ambient temperature outside the enclosure. Statement 1067

- Step 1** Measure a single length of stranded copper wire long enough to connect the power converter to the earth ground. The wire color might differ depending on the country that you are using it in.
- For connections from the power converter to earth ground, use shielded 18-AWG stranded copper wire, such as Belden part number 9912 or the equivalent.
- Step 2** Measure a length of twisted-pair copper wire long enough to connect the power converter to the DC power source.
- For DC connections from the power converter to the DC source, use 18-AWG twisted-pair copper wire, such as Belden part number 9344 or the equivalent.
- Step 3** Using a 18-gauge wire-stripping tool, strip the ground wire and both ends of the twisted pair wires to 0.25 inch (6.3 mm) ± 0.02 inch (0.5 mm). Do not strip more than 0.27 inch (6.8 mm) of insulation from the wires. Stripping more than the recommended amount of wire can leave exposed wire from the power and relay connector after installation. See [Figure B-9](#).
- Step 4** Connect one end of the stranded copper wire to a grounded bare metal surface, such as a ground bus, a grounded DIN rail, or a grounded bare rack.
- Step 5** Insert the other end of the exposed ground wire lead into the earth-ground wire connection on the power converter terminal block. Only wire *with insulation* should extend from the connection. See [Figure B-44](#).
- Step 6** Tighten the earth-ground wire connection terminal block screw.

**Note**

The torque should not exceed 2.2 in-lb (0.25 Nm).

Figure B-44 AC/DC Power Input Terminal Block Wire Connections to a DC Source

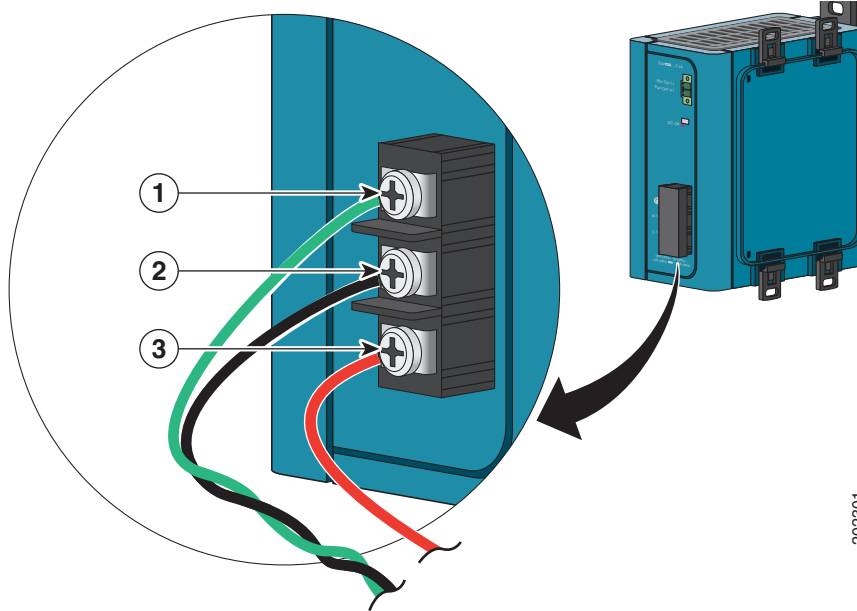

| | | | |
|---|---------------------------------------|---|------------------------|
| 1 | Earth ground wire connection | 3 | Positive DC connection |
| 2 | Return wire connection (to DC return) | | |

**Warning**

An exposed wire lead from a DC-input power source can conduct harmful levels of electricity. Be sure that no exposed portion of the DC-input power source wire extends from the power and relay connector. Statement 122

Step 7 Insert the twisted-pair wire leads into the terminal block line and neutral connections. Insert the wire (labeled number 1 in Figure B-44) lead into the neutral wire connection and the wire (labeled number 2 in Figure B-44) lead into the line wire connection. Ensure that only wire *with insulation* extends from the connectors. See Figure B-44.

Step 8 Tighten the line and neutral terminal block screws.



Note The torque should not exceed 2.2 in-lb (0.25 Nm).

Step 9 Connect the red wire to the positive pole of the DC power source, and connect the black wire to the return pole. Ensure that each pole has a current-limiting-type fuse rated to at least 600 VAC/DC (such as the KLKD Midget fuse).

Applying Power to the Power Converter

Move the circuit breaker for the AC outlet or the DC control circuit to the *on* position.

The LED on the power converter front panel is green when the unit is operating normally. The LED is off when the unit is not powered or is not operating normally. After the power is connected, the switch automatically begins the power-on self-test (POST), a series of tests that verifies that the switch functions properly. For instructions on how to interpret POST results, see the “[Verify POST Results](#)” section on page B-27.

Connecting the Switch to the AC-Input Power Supply

The Cisco IE 3000 switch can be used with an optional AC-input power supply (PWR-IE50W-AC or PWR-IE50W-AC-IEC).

These sections describe the steps required to connect the switch to the AC-input power supply:

- [Attaching the Power Supply to the Switch, page B-61](#)
- [Attaching the Power Supply to the Switch, page B-61](#)
- [Connecting the DC Power Clip, page B-62](#)
- [Connecting the AC-Input Power Supply to an AC Power Source, page B-63](#)

Attaching the Power Supply to the Switch

To attach the AC-input power supply to the switch, follow these steps:

-
- | | |
|---------------|---|
| Step 1 | Remove the left side panel of the switch by firmly grasping both sides of it in the middle and pulling it outward. If necessary, use a screwdriver to open the side panel. See Figure B-38 for an illustration of how to remove the switch side panel. |
| Step 2 | Push the upper module latches (at the top of the switch and the AC-input power supply) up and the lower module latches (at the bottom of the switch and the AC-input power supply) down. See Figure B-39 for an illustration showing the latches operation. |
| Step 3 | Put the two modules together so that the AC-input power supply fits in the switch recess. |
| Step 4 | Push the upper module latches down and the lower module latches up to secure the AC-input power supply to the switch. |
-

Installing the AC-input Power Supply on a DIN Rail, Wall, or Rack Adapter

You install the AC-input power supply on a DIN rail, wall, or rack as you would a switch module. You should first attach the AC-input power supply to the switch and then install the entire switch assembly on the DIN rail, wall, or rack adapter. For more information, see the “Attaching the Power Supply to the Switch” section on page B-61, the “Installing the Switch on a DIN Rail” section on page B-30, the “Installing the Switch on a Wall” section on page B-34, or the “Installing the Switch in a Rack” section on page B-36.



Warning

This equipment is supplied as “open type” equipment. It must be mounted within an enclosure that is suitably designed for those specific environmental conditions that will be present and appropriately designed to prevent personal injury resulting from accessibility to live parts. The interior of the enclosure must be accessible only by the use of a tool.

The enclosure must meet IP 54 or NEMA type 4 minimum enclosure rating standards. Statement 1063



Caution

To prevent the switch assemble from overheating, there must be a minimum of 3 inches (76.19 mm) between any other device and the top, bottom, or sides of the switch assembly.

Connecting the DC Power Clip

The DC power clip (PWR-IE3000-CLP=) is a prewired cable that connects DC power from the power converter to the switch module. Because the power clip uses the Pwr A connector, you cannot use the alarm connections on that connector.

Follow these steps to connect DC power from the AC-input power supply to the switch module.

-
- Step 1** Locate the DC power clip in the AC-input power supply accessory kit.
 - Step 2** Position the power clip so that the two-pin connector is over the power converter and the four-pin connector is over the switch Pwr A connector, and then slide the power clip into these two connectors.
 - Step 3** Use a ratcheting torque flathead screwdriver to tighten the captive screw to 2.2 in-lb (0.25 Nm).



Caution

Do not over-torque the power and relay connector captive screws. The torque should not exceed 2.2 in-lb (0.25 Nm).

Connecting the AC-Input Power Supply to an AC Power Source

To connect the power converter to an AC power source, you need an AC power cord. Power cord connector types and standards vary by country. Power-cord wiring color codes also vary by country. You must have a qualified electrician select, prepare, and install the appropriate power cord on the PWR-IE50W-AC power supply.



Note

Use copper conductors only, rated at a minimum temperature of 167°F (75°C).

For the AC-input power supply equipped with an IEC C14 appliance connector (PWR-IE50W-AC-IEC), you need to obtain an AC power cord with a suitable AC plug for your locality on one end and a C13 appliance connector on the other end. To connect source AC to the power supply, plug the AC power cord appliance connector into the power supply AC in connector. Plug the other end of the AC power cord into a dedicated source AC outlet.

Connecting the AC Power Cord to the Power Supply

This procedure is intended for a qualified electrician who has selected and prepared an appropriate AC power cord for the PWR-IE50W-AC power supply.



Caution

AC power sources must be on dedicated AC branch circuits. Each branch circuit must be protected by a dedicated two-pole circuit breaker.



Caution

Do not insert the power cord plug into the AC outlet until you have completed wiring the line, neutral, and ground connections.

To connect the AC power cord wires to the power supply, follow these steps:

- Step 1** Remove the plastic cover from the input power terminals and set it aside.
- Step 2** Loosen the three Phillips-head terminal screws on the terminal block.
- Step 3** Insert the exposed ground wire lead into the power supply ground wire connection on the terminal block. Ensure that only wire *with insulation* extends from the connector. Connecting AC Power to the Power Converter
- Step 4** Tighten the ground wire terminal block screw.



Note

The torque should not exceed 2.2 in-lb (0.25 Nm).

- Step 5** Insert the line and neutral wire leads into the terminal block line and neutral connections. Make sure that you cannot see any wire lead. Ensure that only wire *with insulation* extends from the connectors.
- Step 6** Tighten the line and neutral terminal block screws.



Note

The torque should not exceed 2.2 in-lb (0.25 Nm).

- Step 7** Replace the plastic cover over the terminal block.
- Step 8** Connect the other end of the AC power cord to the AC outlet.
-

Where to Go Next

If the default configuration is satisfactory, the switch does not need further configuration. You can use any of these management options to change the default configuration:

- Start the device manager, which is in the switch memory, to manage individual and standalone switches. This is an easy-to-use web interface that offers quick configuration and monitoring. You can access the device manager from anywhere in your network through a web browser. For more information, see the switch getting started guide and the device manager online help.
- Start the Cisco Network Assistant application, which is described in the *Getting Started with Cisco Network Assistant* guide. Through this GUI, you can configure and monitor a switch cluster or an individual switch.
- Use the CLI to configure the switch as an individual switch from the console. See the switch command reference on Cisco.com for information about using the CLI.
- Start an SNMP application such as the CiscoView application.
- Start the Common Industrial Protocol (CIP) management tool. You can manage an entire industrial automation system with CIP-based tools.



Cable and Connectors

This appendix describes the switch ports and the cables and adapters that you use to connect the switch to other devices.

Connector Specifications

These sections describe the connectors used with the Cisco IE 3000 switch.

10/100 Ports

The 10/100 and 10/100/1000 Ethernet ports on switches use standard RJ-45 connectors and Ethernet pinouts with internal crossovers. [Figure C-1](#) and [Figure C-2](#) show the pinouts.

The auto-MDIX feature described briefly in this guide is enabled by default. For configuration information for this feature, see the switch software configuration guide or the switch command reference.

The PoE ports on the PoE expansion modules integrate power and data signals on the same wires. The ports use standard RJ-45 connectors and Ethernet pinouts with internal crossovers. [Figure C-1](#) shows the pinouts.

Connecting to 10BASE-T- and 100BASE-TX-Compatible Devices

When connecting the ports to 10BASE-T- and 100BASE-TX-compatible devices, such as servers, workstations, and routers, you can use a two or four twisted-pair, straight-through cable wired for 10BASE-T and 100BASE-TX. [Figure C-5](#) shows the two twisted-pair, straight-through cable schematics. [Figure C-7](#) shows the four twisted-pair, straight-through cable schematics.

When connecting the ports to 10BASE-T- and 100BASE-TX-compatible devices, such as switches or repeaters, you can use a two or four twisted-pair, crossover cable. [Figure C-6](#) shows the two twisted-pair, crossover cable schematics. [Figure C-8](#) shows the four twisted-pair, crossover cable schematics.

You can use Category 3, 4, or 5 cabling when connecting to 10BASE-T-compatible devices. You must use Category 5 cabling when connecting to 100BASE-TX-compatible devices.

Connecting to 1000BASE-T Devices

When connecting the ports to 1000BASE-T devices, such as servers, workstations, and routers, you must use a four twisted-pair, Category 5, straight-through cable wired for 10BASE-T, 100BASE-TX, and 1000BASE-T. [Figure C-7](#) shows the straight-through cable schematics.

When connecting the ports to other devices, such as switches or repeaters, you must use a four twisted-pair, Category 5, crossover cable. [Figure C-8](#) shows the crossover cable schematics.

Note

Use a straight-through cable to connect two ports only when one port is designated with an X. Use a crossover cable to connect two ports when both ports are designated with an X or when both ports do not have an X.

Figure C-1 10/100 Port Pinouts

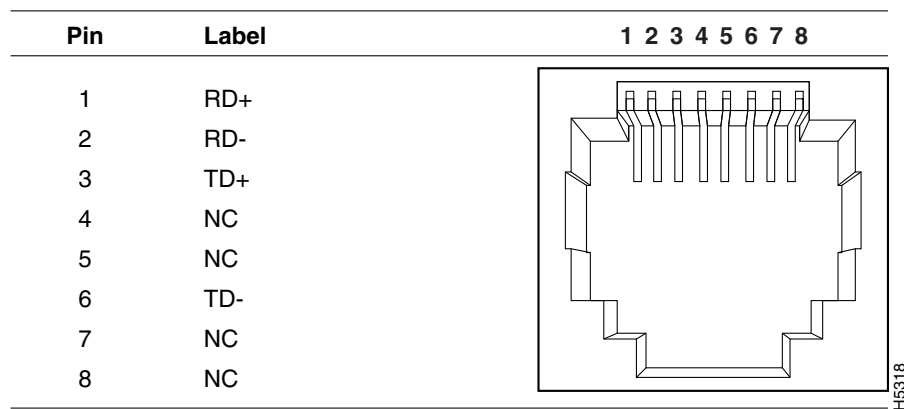
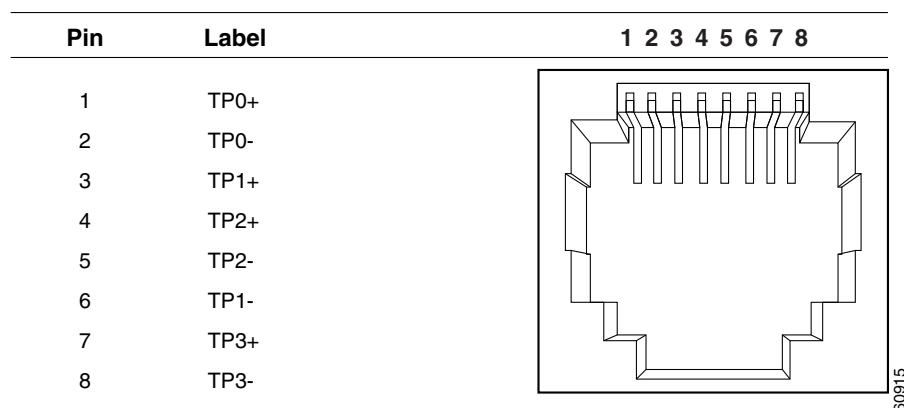

Figure C-2 10/100/1000 Port Pinouts



100BASE-FX Ports

The 100BASE-FX ports use MT-RJ connectors. See [Figure C-3](#). The 100BASE-FX ports use 50/125- or 62.5/125-micron multimode fiber-optic cabling.

Figure C-3 Fiber-Optic SFP Module LC Connector

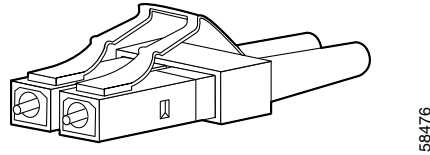

Warning

Invisible laser radiation may be emitted from disconnected fibers or connectors. Do not stare into beams or view directly with optical instruments.

PoE Expansion Module Ports (IEM-3000-4PC and IEM-3000-4PC-4TC Only)

This section applies only to the Cisco IEM-3000-4PC and the Cisco IEM-3000-4PC-4TC PoE expansion modules only.



Warning

Voltages that present a shock hazard may exist on Power over Ethernet (PoE) circuits if interconnections are made using uninsulated exposed metal contacts, conductors, or terminals. Avoid using such interconnection methods, unless the exposed metal parts are located within a restricted access location and users and service people who are authorized within the restricted access location are made aware of the hazard. A restricted access area can be accessed only through the use of a special tool, lock and key or other means of security. Statement 1072

- Each of the four PoE ports on the IEM-3000-4PC or the IEM-3000-4PC-4TC deliver up to 15.4 W of PoE.
- Two ports on each PoE expansion module can also be configured as PoE+ ports (up to 30 W of PoE) for non-office/computer room environments (IEC 60950). The remainder of the ports are non-PoE.
- On a per-port basis, you can control whether or not a PoE port automatically provides power when an IP phone or a powered device is connected. The device manager, Network Assistant, and the CLI provide PoE settings for each PoE port:
 - Auto: When you select the Auto setting, the port provides power only if a valid powered device, such as an IEEE 802.3af-compliant powered device is connected. The Auto setting is the default.
 - Never: When you select the Never setting, the port does not provide power even if a powered device is connected.
- You also can connect a powered device to the PoE expansion module port and to an external power source for redundant power. The powered device might switch to the AC power source as its primary power source upon being connected to it. In that case, the PoE port becomes the backup power source for the powered device. If the primary source fails, the second power source becomes the primary power source to the powered device. During the power transfer, the powered device might reboot or reestablish link with the switch.

For information about configuring and monitoring PoE ports, see the switch software configuration guide.

SFP Transceiver Ports

The switch uses SFP transceivers for fiber-optic uplink ports (see [Figure C-3](#)) and for copper SFP ports (see [Figure C-4](#)). See the switch release notes for a list of supported SFP transceivers.



Warning

Invisible laser radiation may be emitted from disconnected fibers or connectors. Do not stare into beams or view directly with optical instruments.

Figure C-4 Copper SFP Transceiver RJ-45 Connector

| Pin | Label | 1 2 3 4 5 6 7 8 |
|-----|-------|-----------------|
| 1 | TP0+ | |
| 2 | TP0- | |
| 3 | TP1+ | |
| 4 | TP2+ | |
| 5 | TP2- | |
| 6 | TP1- | |
| 7 | TP3+ | |
| 8 | TP3- | |

Dual-Purpose Ports

The Ethernet port on a dual-purpose port uses standard RJ-45 connectors. [Figure C-2](#) shows the pinouts.

The SFP transceiver slot on a dual-purpose port uses SFP modules for fiber-optic and copper uplink ports. See the switch release notes for a list of supported SFP transceivers.

The auto-MDIX feature is enabled by default. For configuration information for this feature, see the switch software configuration guide or the switch command reference.

Console Port

The console port uses an 8-pin RJ-45 connector, which is described in [Table C-2](#) and [Table C-2](#). The supplied RJ-45-to-DB-9 adapter cable is used to connect the console port of the switch to a console PC. You need to provide a RJ-45-to-DB-25 female DTE adapter if you want to connect the switch console port to a terminal. You can order a kit (part number ACS-DSBUASYN=) containing that adapter from Cisco. For console port and adapter pinout information, see [Table C-2](#) and [Table C-3](#).

Cable and Adapter Specifications

These sections describe the cables and adapters used with Cisco IE 3000 switches.

- [SFP Transceiver Cable Specifications, page C-5](#)
- [Two Twisted-Pair Cable Pinouts, page C-8](#)
- [Four Twisted-Pair Cable Pinouts for 1000BASE-T Ports, page C-9](#)
- [Crossover Cable and Adapter Pinouts, page C-10](#)
- [Four Twisted-Pair Cable Pinouts for 1000BASE-T Ports, page C-9](#)

SFP Transceiver Cable Specifications

[Table C-1](#) lists the cable specifications for the rugged fiber-optic SFP transceiver connections. Each port must match the wave-length specifications on the other end of the cable, and for reliable communications, the cable must not exceed the required cable length. Copper 1000BASE-T SFP transceivers use standard four twisted-pair, Category 5 or greater cable at lengths up to 328 feet (100 meters).

Table C-1 Fiber-Optic SFP Transceiver Port Cabling Specifications

| SFP Transceiver | Wavelength (nanometers) | Fiber Type | Core Size/Cladding Size (micron) | Modal Bandwidth (MHz/km) ¹ | Cable Distance |
|--|---|------------|--|---------------------------------------|--|
| Industrial and Rugged SFPs | | | | | |
| 1000BASE-SX (GLC-SX-MM-RGD) | 850 | MMF | 62.5/125 62.5/125 50/125 50/125 | 160 200 400 500 | 722 feet (220 m) 902 feet (275 m) 1640 feet (500 m) 1804 feet (550 m) |
| 1000BASE-LX/LH (GLC-LX-SM-RGD) | 1310 | SMF | G.652 ² | — | 32,810 feet (10 km) |
| 100BASE-LX (GLC-FE-100LX-RGD) | 1310 | SMF | G.652 ² | — | 32,810 feet (10 km) |
| 100BASE-FX (GLC-FE-100FX-RGD) | 1310 | MMF | 50/125 62.5/125 | 500 500 | 6,562 feet (2 km) 6,562 feet (2 km) |
| 1000BASE-ZX (GLC-ZX-SM-RGD) | 1550 | SMF | G.652 ² | — | 43.4 to 62 miles (70 to 100 km) ² |
| 1000BASE-BX-D (GLC-BX40-D-I GLC-BX40-DA-I GLC-BX80-D-I) | 1550 1490 1570 | SMF | G.652 | — | 24.9 miles (40 km) 24.9 miles (40 km) 49.8 miles (80 km) |
| 1000BASE-BX-U (GLC-BX40-U-I GLC-BX80-U-I) | 1310 1490 | SMF | G.652 | — | 24.9 miles (40 km) 49.8 miles (80 km) |
| Commercial SFPs | | | | | |
| 1000BASE-BX10-D (GLC-BX-D) | 1490 TX 1310 RX | SMF | G.652 ³ | — | 32,810 feet (10 km) |
| 1000BASE-BX10-U (GLC-BX-U) | 1310 TX 1490 RX | SMF | G.652 | — | 32,810 feet (10 km) |
| 100BASE-LX (GLC-FE-100LX) | 1310 | SMF | G.652 ² | — | 32,810 feet (10 km) |
| 100BASE-BX (GLC-FE-100BX-D GLC-FE-100BX-U) | 1310 TX 1550 RX | SMF | G.652 ² | — | 32,810 feet (10 km) |
| 100BASE-FX (GLC-FE-100FX) | 1310 | MMF | 50/125 62.5/125 | 500 500 | 6,562 feet (2 km) 6,562 feet (2 km) |
| 100BASE-EX (GLC-FE-100EX) | 1310 | SMF | G.652 ² | — | 131,240 feet (40 km) |
| 100BASE-ZX (GLC-FE-100ZX) | 1550 | SMF | G.652 ² | — | 262,480 feet (80 km) |
| 1000BASE-DWDM CWDM | 1470, 1490, 1510, 1530, 1550, 1570, 1590, 1610 | SMF | G.652 ² | — | 62 miles (100 km) |

Table C-1 Fiber-Optic SFP Transceiver Port Cabling Specifications (continued)

| SFP Transceiver | Wavelength (nanometers) | Fiber Type | Core Size/Cladding Size (micron) | Modal Bandwidth (MHz/km) ¹ | Cable Distance |
|----------------------------------|---|----------------|----------------------------------|---------------------------------------|--|
| 1000BASE-DWDM DWDM | 1530.33, 1531.12, 1531.90, 1532.68, 1534.25, 1535.04, 1535.82, 1538.19, 1539.77, 1539.98, 1539.77, 1540.56, 1542.14, 1542.94, 1544.53, 1546.12, 1546.92, 1547.72, 1548.51, 1550.12, 1550.92, 1551.72, 1552.52, 1554.13, 1554.94, 1555.75, 1556.55, 1558.17, 1558.98, 1559.79, 1560.61 | SMF | G.652 | — | 62 miles (100 km) |
| 1000BASE-T GLC-T | — | MMF | — | — | 328 feet (100 m) |
| Extended temperature SFPs | | | | | |
| 1000BASE LX/LH (SFP-GE-L) | 1300 | MMF or SMF | 62.2 50 50 9/10 | 500 400 500 — | 1804 feet (550 m) 1804 feet (550 m) 1804 feet (550 m) 6.2 miles (10 km) |
| 1000BASE LX/LH (GLC-LH-SMD) | 1310 | MMF SMF | 62.5 50.0 50.0 G.652 | 500 400 500 — | 1804 feet (550 m) 1804 feet (550 m) 1804 feet (550 m) 6.2 miles (10 km) |
| 100BASE SX (SFP-GE-S) | 850 | MMF | 62.5 62.5 50.0 50.0 | 160 200 400 500 | 722 feet (220 m) 902 feet (275 m) 1640 feet (500 m) 1804 feet (550 m) |

Table C-1 Fiber-Optic SFP Transceiver Port Cabling Specifications (continued)

| SFP Transceiver | Wavelength (nanometers) | Fiber Type | Core Size/Cladding Size (micron) | Modal Bandwidth (MHz/km) ¹ | Cable Distance |
|-----------------------------|-------------------------|------------|----------------------------------|---------------------------------------|---|
| 1000BASE SX GLC-SX-MMD | 850 | MMF | 62.5 | 160 | 722 feet (220 m) |
| | | | 62.5 | 200 | 902 feet (275 m) |
| | | | 50.0 | 400 | 1640 feet (500 m) |
| | | | 50.0 | 500 | 1804 feet (550 m) |
| | | | 50.0 | 2000 | 3281 feet (1 km) |
| 1000BASE ZX (SFP-GE-Z) | 1550 | SMF | 9/10 | — | 43.5 miles (70 km) |
| | | | 8 | — | 62.1 miles (100 km) |
| 1000BASE ZX (GLC-ZX-SMD) | 1550 | SMF | — | — | 43.5 miles (70 km) 62.1 miles (100 km) |
| 1000BASE EX (GLC-EX-SMD) | 1310 | SMF | G.652 ² | — | 24.9 miles (40 km) |

1. Modal bandwidth applies only to multimode fiber.
2. 1000BASE-ZX SFP modules can send data up to 62 miles (100 km) by using dispersion-shifted SMF or low-attenuation SMF; the distance depends on the fiber quality, the number of splices, and the connectors.
3. A mode-field diameter/cladding diameter = 9 micrometers/125 micrometers.



When the fiber-optic cable span is less than 15.43 miles (25 km), insert a 5-decibel (dB) or 10-dB inline optical attenuator between the fiber-optic cable plant and the receiving port on the 1000BASE-ZX SFP module.

Two Twisted-Pair Cable Pinouts

Figure C-5 and Figure C-6 show the schematics of two twisted-pair cables for connecting to 10BASE-T- and 100BASE-TX-compatible devices.

Figure C-5 Two Twisted-Pair Straight-Through Cable Schematic

Figure C-6 Two Twisted-Pair Crossover Cable Schematic



Four Twisted-Pair Cable Pinouts for 1000BASE-T Ports

Figure C-7 and Figure C-8 show the schematics of four twisted-pair cables for 10/100/1000 ports on the Cisco IE 3000 switches.

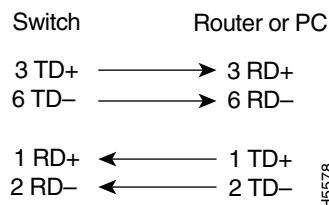
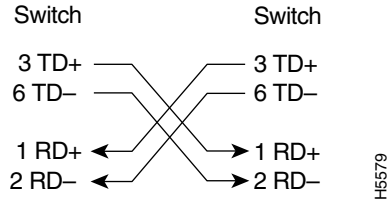
Figure C-7 Four Twisted-Pair Straight-Through Cable Schematic for 10/100/1000 Ports

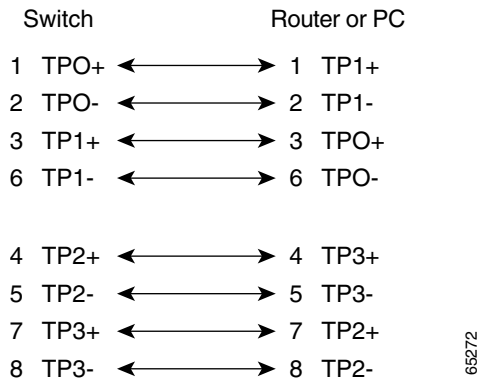
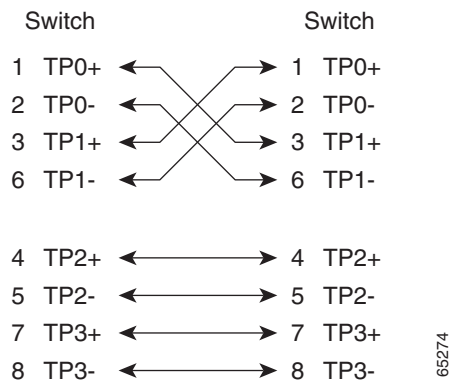

Figure C-8 Four Twisted-Pair Crossover Cable Schematics for 10/100/1000 Ports



Crossover Cable and Adapter Pinouts

This section describes how to identify a crossover cable and also describes the adapter pinouts.

Identifying a Crossover Cable

To identify a crossover cable, compare the two modular ends of the cable. Hold the cable ends side-by-side, with the tab at the back. The wire connected to the pin on the outside of the left plug should be a different color from the wire connected to the pin on the inside of the right plug. (See [Figure C-9](#).)

Figure C-9 Identifying a Crossover Cable

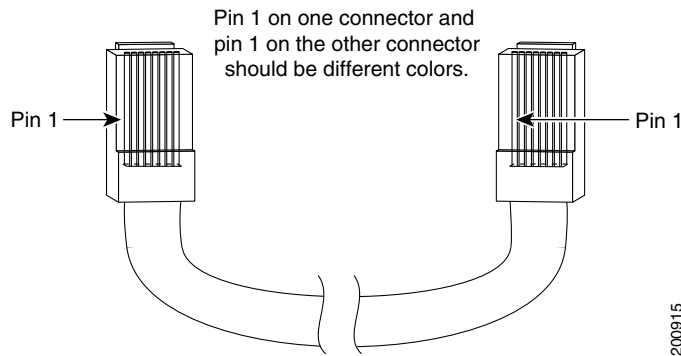

Adapter Pinouts

[Table C-2](#) lists the pinouts for the console port, the RJ-45-to-DB-9 adapter cable, and the console device.

Table C-2 Console Port Signaling Using a DB-9 Adapter

| Switch Console Port (DTE) | RJ-45-to-DB-9 Terminal Adapter | Console Device |
|---------------------------|--------------------------------|----------------|
| Signal | DB-9 Pin | Signal |
| RTS | 8 | CTS |
| DTR | 6 | DSR |
| TxD | 2 | RxD |
| GND | 5 | GND |
| GND | 5 | GND |
| RxD | 3 | TxD |
| DSR | 4 | DTR |
| CTS | 7 | RTS |

Table C-3 lists the pinouts for the console port, RJ-45-to-DB-25 female DTE adapter, and the console device.

**Note**

The RJ-45-to-DB-25 female DTE adapter is not supplied with the switch. You can order a kit (part number ACS-DSBUASYN=) containing this adapter from Cisco.

Table C-3 Console Port Signaling Using a DB-25 Adapter

| Switch Console Port (DTE) | RJ-45-to-DB-25 Terminal Adapter | Console Device |
|---------------------------|---------------------------------|----------------|
| Signal | DB-25 Pin | Signal |
| RTS | 5 | CTS |
| DTR | 6 | DSR |
| TxD | 3 | RxD |
| GND | 7 | GND |
| GND | 7 | GND |
| RxD | 2 | TxD |
| DSR | 20 | DTR |
| CTS | 4 | RTS |



Configuring the Switch with the CLI-Based Setup Program

This appendix provides a command-line interface (CLI)-based setup procedure for a standalone switch. For information about setting up the switch by using Express Setup, see the *Cisco IE 3000 Switch Getting Started Guide*.

Before connecting the switch to a power source, review the safety warnings in [Chapter 2, “Switch Installation.”](#)

For installation procedures for mounting your switch, connecting to the switch ports, or connecting to the small form-factor pluggable (SFP) modules, see [Chapter 2, “Switch Installation.”](#)

Accessing the CLI from the Console Port

You can access the CLI on a configured or unconfigured switch by connecting the console port of the switch to your PC or workstation and accessing the switch through a terminal emulation program.

To connect to the console port, follow these steps:

1. Using the supplied RJ-45-to-DB-9 adapter cable, insert the RJ-45 connector into the console port on the switch front panel ([Figure 1-1](#)) and to the PC or terminal port.
2. Start the terminal-emulation program on the PC or terminal. The terminal-emulation software, frequently a PC application such as Hyperterminal or ProcommPlus, makes communication between the switch and your PC or terminal possible.
3. Start a terminal-emulation session.
4. Configure the baud rate and character format of the PC or terminal to match these console port default characteristics:
 - 9600 bits per second
 - 8 data bits
 - 1 stop bit
 - No parity
 - None (flow control)
5. Power on the switch as described in the switch getting started guide and in the [“Verifying Switch Operation”](#) section on page 2-13.

The PC or terminal displays the bootloader sequence. Press **Enter** to display the setup prompt. Follow the steps described in the “[Entering the Initial Configuration Information](#)” section on page D-2.

Entering the Initial Configuration Information

To set up the switch, you need to complete the setup program, which runs automatically after the switch is powered on. You must assign an IP address and other configuration information necessary for the switch to communicate with the local routers and the Internet. This information is also required if you plan to use the device manager or Cisco Network Assistant to configure and manage the switch.

IP Settings

You need this information from your network administrator before you complete the setup program:

- Switch IP address
- Subnet mask (IP netmask)
- Default gateway (router)
- Enable secret password
- Enable password
- Telnet password

Completing the Setup Program

Follow these steps to complete the setup program and to create an initial configuration for the switch:

Step 1 Enter **Yes** at these two prompts.

Would you like to enter the initial configuration dialog? [yes/no]: **yes**

At any point you may enter a question mark '?' for help.
Use ctrl-c to abort configuration dialog at any prompt.
Default settings are in square brackets '['].

Basic management setup configures only enough connectivity
for management of the system, extended setup will ask you
to configure each interface on the system.

Would you like to enter basic management setup? [yes/no]: **yes**

Step 2 Enter a hostname for the switch, and press **Return**.

On a command switch, the hostname is limited to 28 characters; on a member switch to 31 characters. Do not use *-n*, where *n* is a number, as the last character in a hostname for any switch.

Enter host name [Switch]: *host_name*

Step 3 Enter an enable secret password, and press **Return**.

The password can be from 1 to 25 alphanumeric characters, can start with a number, is case sensitive, allows spaces, but ignores leading spaces. The secret password is encrypted, and the enable password is in plain text.

```
Enter enable secret: secret_password
```

Step 4 Enter an enable password, and press **Return**.

```
Enter enable password: enable_password
```

Step 5 Enter a virtual terminal (Telnet) password, and press **Return**.

The password can be from 1 to 25 alphanumeric characters, is case sensitive, allows spaces, but ignores leading spaces.

```
Enter virtual terminal password: terminal-password
```

Step 6 (Optional) Configure Simple Network Management Protocol (SNMP) by responding to the prompts. You can also configure SNMP later through the CLI, the device manager, or the Cisco Network Assistant application. To configure SNMP later, enter **no**.

```
Configure SNMP Network Management? [no]: no
```

Step 7 Enter the interface name (physical interface or VLAN name) of the interface that connects to the management network, and press **Return**. For this release, always use **vlan1** as that interface.

```
Enter interface name used to connect to the  
management network from the above interface summary: vlan1
```

Step 8 Configure the interface by entering the switch IP address and subnet mask and pressing **Return**. The IP address and subnet masks shown below are examples.

```
Configuring interface vlan1:  
Configure IP on this interface? [yes]: yes  
IP address for this interface: 10.4.120.106  
Subnet mask for this interface [255.0.0.0]: 255.0.0.0
```

Step 9 Enter **Y** to configure the switch as the cluster command switch. Enter **N** to configure it as a member switch or as a standalone switch.

If you enter **N**, the switch appears as a candidate switch in the Cisco Network Assistant GUI. You can configure the switch as a command switch later through the CLI, the device manager, or the Cisco Network Assistant application. To configure it later, enter **no**.

```
Would you like to enable as a cluster command switch? [yes/no]: no
```

You have now completed the initial configuration of the switch, and the switch displays its initial configuration script:

The following configuration command script was created:

```
hostname Switch  
enable secret 5 $1$ZQRe$DPuLYXyQLm77v/a4Bmu6Y.  
enable password cisco  
line vty 0 15  
password cisco  
no snmp-server  
!  
!  
interface Vlan1  
no shutdown  
ip address 10.4.120.106 255.0.0.0  
!
```

```

interface FastEthernet1/1
!
interface FastEthernet1/2
!
interface FastEthernet1/3
!
...(output abbreviated)
!
interface GigabitEthernet1/1
!
interface GigabitEthernet1/2
!
end

```

Step 10 These choices appear:

[0] Go to the IOS command prompt without saving this config.

[1] Return back to the setup without saving this config.

[2] Save this configuration to nvram and exit.

If you want to save the configuration and use it the next time the switch reboots, save it in NVRAM by selecting option 2.

Enter your selection [2]:2

Make your selection, and press **Return**.

After you complete the setup program, the switch can run the default configuration that you created. If you want to change this configuration or want to perform other management tasks, use one of these tools:

- Command-line interface (CLI)
- Cisco Network Assistant (for one or more switches)

To use the CLI, enter commands at the *Switch>* prompt through the console port by using a terminal emulation program or through the network by using Telnet. For configuration information, see the switch software configuration guide or the switch command reference.

To use the Cisco Network Assistant, see the *Getting Started with Cisco Network Assistant* guide on Cisco.com.