



Cisco IE 2000 Switch Hardware Installation Guide

First Published: June 2012

Last Updated: February 2016

THE SPECIFICATIONS AND INFORMATION REGARDING THE PRODUCTS IN THIS MANUAL ARE SUBJECT TO CHANGE WITHOUT NOTICE. ALL STATEMENTS, INFORMATION, AND RECOMMENDATIONS IN THIS MANUAL ARE BELIEVED TO BE ACCURATE BUT ARE PRESENTED WITHOUT WARRANTY OF ANY KIND, EXPRESS OR IMPLIED. USERS MUST TAKE FULL RESPONSIBILITY FOR THEIR APPLICATION OF ANY PRODUCTS.

THE SOFTWARE LICENSE AND LIMITED WARRANTY FOR THE ACCOMPANYING PRODUCT ARE SET FORTH IN THE INFORMATION PACKET THAT SHIPPED WITH THE PRODUCT AND ARE INCORPORATED HEREIN BY THIS REFERENCE. IF YOU ARE UNABLE TO LOCATE THE SOFTWARE LICENSE OR LIMITED WARRANTY, CONTACT YOUR CISCO REPRESENTATIVE FOR A COPY.

The following information is for FCC compliance of Class A devices: This equipment has been tested and found to comply with the limits for a Class A digital device, pursuant to part 15 of the FCC rules. These limits are designed to provide reasonable protection against harmful interference when the equipment is operated in a commercial environment. This equipment generates, uses, and can radiate radio-frequency energy and, if not installed and used in accordance with the instruction manual, may cause harmful interference to radio communications. Operation of this equipment in a residential area is likely to cause harmful interference, in which case users will be required to correct the interference at their own expense.

The following information is for FCC compliance of Class B devices: This equipment has been tested and found to comply with the limits for a Class B digital device, pursuant to part 15 of the FCC rules. These limits are designed to provide reasonable protection against harmful interference in a residential installation. This equipment generates, uses and can radiate radio frequency energy and, if not installed and used in accordance with the instructions, may cause harmful interference to radio communications. However, there is no guarantee that interference will not occur in a particular installation. If the equipment causes interference to radio or television reception, which can be determined by turning the equipment off and on, users are encouraged to try to correct the interference by using one or more of the following measures:

- Reorient or relocate the receiving antenna.
- Increase the separation between the equipment and receiver.
- Connect the equipment into an outlet on a circuit different from that to which the receiver is connected.
- Consult the dealer or an experienced radio/TV technician for help.

Modifications to this product not authorized by Cisco could void the FCC approval and negate your authority to operate the product.

The Cisco implementation of TCP header compression is an adaptation of a program developed by the University of California, Berkeley (UCB) as part of UCB's public domain version of the UNIX operating system. All rights reserved. Copyright © 1981, Regents of the University of California.

NOTWITHSTANDING ANY OTHER WARRANTY HEREIN, ALL DOCUMENT FILES AND SOFTWARE OF THESE SUPPLIERS ARE PROVIDED "AS IS" WITH ALL FAULTS. CISCO AND THE ABOVE-NAMED SUPPLIERS DISCLAIM ALL WARRANTIES, EXPRESSED OR IMPLIED, INCLUDING, WITHOUT LIMITATION, THOSE OF MERCHANTABILITY, FITNESS FOR A PARTICULAR PURPOSE AND NONINFRINGEMENT OR ARISING FROM A COURSE OF DEALING, USAGE, OR TRADE PRACTICE.

IN NO EVENT SHALL CISCO OR ITS SUPPLIERS BE LIABLE FOR ANY INDIRECT, SPECIAL, CONSEQUENTIAL, OR INCIDENTAL DAMAGES, INCLUDING, WITHOUT LIMITATION, LOST PROFITS OR LOSS OR DAMAGE TO DATA ARISING OUT OF THE USE OR INABILITY TO USE THIS MANUAL, EVEN IF CISCO OR ITS SUPPLIERS HAVE BEEN ADVISED OF THE POSSIBILITY OF SUCH DAMAGES.

Any Internet Protocol (IP) addresses and phone numbers used in this document are not intended to be actual addresses and phone numbers. Any examples, command display output, network topology diagrams, and other figures included in the document are shown for illustrative purposes only. Any use of actual IP addresses or phone numbers in illustrative content is unintentional and coincidental.

All printed copies and duplicate soft copies are considered un-Controlled copies and the original on-line version should be referred to for latest version.

Cisco has more than 200 offices worldwide. Addresses, phone numbers, and fax numbers are listed on the Cisco website at www.cisco.com/go/offices.

© 2012-2016 Cisco Systems, Inc. All rights reserved.



Contents

- Preface 5
 - Audience 5
 - Purpose 5
 - Conventions 5
 - Related Publications 6

- Product Overview 7
 - Overview 7
 - Switch Models 8
 - Front Panel Overview 10
 - Ports and Slots 14
 - 10/100BASE-T Downlink Ports 15
 - 10/100BASE-T Uplink Ports 15
 - 10/100/1000BASE-T Uplink Ports 15
 - 100 Mb/s SFP Module Downlink Slots 15
 - 100/1000 Mb/s SFP Module Uplink Slots 15
 - 10/100/1000BASE-T Copper SFP Module Uplink Slots 15
 - Dual-Purpose Fast Ethernet Uplink Ports 15
 - Dual-Purpose Gigabit Ethernet Uplink Ports 16
 - Power over Ethernet Ports 16
 - Management Ports 16
 - Power Connectors 17
 - DC Power Connector 17
 - PoE Power Connector 17
 - Alarm Connector 18
 - SFP Modules 19
 - SFP Module Patch Cable 20
 - LEDs 20
 - Express Setup LED 21
 - System LED 22
 - USB-Mini Console LED 22
 - Alarm LEDs 22
 - Power Status LEDs 23
 - Port Status LEDs 23
 - Dual-Purpose Port LEDs 23
 - PoE Status LED 24

Flash Memory Card	25
Rear Panel	25
Management Options	26
Network Configurations	27
Switch Installation	29
Preparing for Installation	29
Warnings	29
Additional Information for Installation in a Hazardous Environment	30
Hazardous Area Installation Warnings	30
North American Hazardous Location Approval	31
EMC Environmental Conditions for Products Installed in the European Union	32
Installation Guidelines	32
Environment and Enclosure Guidelines	32
General Guidelines	32
Verifying Package Contents	33
Installing or Removing the Flash Memory Card (Optional)	33
Connecting to a Console Port	35
RJ-45 Console Port	35
USB Mini-Type B Console Port	36
Connecting to Power	39
Tools and Equipment	39
Supported Power Supplies	39
Installing the Power Converter on a DIN Rail, Wall, or Rack Adapter	40
Grounding the Switch	40
Connecting the Power Converter to an AC Power Source	43
Preparing the AC Power Connection	43
Connecting the AC Power Source to the Power Converter	44
Connecting the Power Converter to a DC Power Source	44
Wiring the DC Power Source	46
Attaching the Power Connectors to the Switch	51
Connecting Power to the Switch PoE DC-Input (Optional)	53
Applying Power to the Power Converter	56
Running Boot Fast	56
Powering On the Switch	56
Verifying Boot Fast	56
Disconnecting Power	56
Installing the Switch	56
Installing the Switch on a DIN Rail	57
Removing the Switch from a DIN Rail	58
Connecting Alarm Circuits	59
Wiring the Protective Ground and DC Power for Alarm Circuits	59

Wiring the External Alarms	59
Attaching the Alarm Connector to the Switch.	63
Connecting Destination Ports	64
Connecting to 10/100 and 10/100/1000 Ports	64
Installing and Removing SFP Modules	66
Installing LC SFP Modules	67
Installing 1000BASE-T SFP Modules	68
Removing SFP Modules from SFP Module Slots	69
Connecting to SFP Modules	70
Connecting to a Fiber Optic SFP Module	70
Connecting to a 1000BASE-T SFP Module	71
Connecting to a Dual-Purpose Port.	72
Verifying Switch Operation	73
Where to Go Next.	73
Troubleshooting	75
Diagnosing Problems	75
Switch Boot Fast.	75
Switch LEDs	75
Switch Connections	75
Bad or Damaged Cable	75
Ethernet and Fiber-Optic Cables	76
Link Status.	76
10/100 and 10/100/1000 Port Connections	76
SFP Module.	76
Interface Settings	77
Ping End Device	77
Spanning Tree Loops.	77
Switch Performance	77
Speed, Duplex, and Autonegotiation	77
Autonegotiation and Network Interface Cards	77
Cabling Distance	78
Resetting the Switch.	78
How to Recover Passwords	78
Finding the Switch Serial Number	78
Technical Specifications	81
Operating Temperature Specifications	81
Technical Specifications	81
Alarm Ratings	85
Hazardous Locations Standards	86

Cable and Connectors	87
Connector Specifications	87
10/100 Ports	87
SFP Module Connectors	88
Dual-Purpose Ports	88
Console Port	89
Alarm Port	89
Cables and Adapters	90
SFP Module Cables	90
Cable Pinouts	93
Console Port Adapter Pinouts	94
Running Express Setup	97
Configuring the Switch with the CLI-Based Setup Program	101
Accessing the CLI Through the Console Port	101
Removing the USB Mini-Type B Console Port Cover	101
RJ-45 Console Port	102
USB Mini-Type B Console Port	103
Installing the Cisco Microsoft Windows XP, 2000, Vista, 7, 8, and 10 USB Device Driver 105	
Uninstalling the Cisco Microsoft Windows XP, 2000, Vista, 7, 8, and 10 USB Driver	106
Entering the Initial Configuration Information	106
IP Settings	106
Completing the Setup Program	106



Preface

Audience

This guide is for the network or computer technician responsible for installing Cisco IE 2000 series switches. We assume that you are familiar with the concepts and terminology of Ethernet and local area networks.

Purpose

This guide documents the hardware features of the Cisco IE 2000 switches. It describes the physical and performance characteristics of each switch, explains how to install a switch, and provides troubleshooting information.

This guide does not describe system messages that you might receive or how to configure your switch. For more information, see the Cisco IE2000 documentation at

http://www.cisco.com/en/US/products/ps12451/tsd_products_support_series_home.html

For information about the standard Cisco IOS commands, see

<http://www.cisco.com/cisco/web/psa/configure.html?mode=prod&level0=268438303>

Conventions

This document uses the following conventions.

Conventions	Indication
bold font	Commands and keywords and user-entered text appear in bold font .
<i>italic font</i>	Document titles, new or emphasized terms, and arguments for which you supply values are in <i>italic font</i> .
[]	Elements in square brackets are optional.
{x y z }	Required alternative keywords are grouped in braces and separated by vertical bars.
[x y z]	Optional alternative keywords are grouped in brackets and separated by vertical bars.
string	A nonquoted set of characters. Do not use quotation marks around the string or the string will include the quotation marks.
courier font	Terminal sessions and information the system displays appear in courier font.
< >	Nonprinting characters such as passwords are in angle brackets.
[]	Default responses to system prompts are in square brackets.
!, #	An exclamation point (!) or a pound sign (#) at the beginning of a line of code indicates a comment line.

Note: Means *reader take note*. Notes contain helpful suggestions or references to material not covered in the manual.

Caution: Means *reader be careful*. In this situation, you might perform an action that could result in equipment damage or loss of data.

Warning: IMPORTANT SAFETY INSTRUCTIONS

Means danger. You are in a situation that could cause bodily injury. Before you work on any equipment, be aware of the hazards involved with electrical circuitry and be familiar with standard practices for preventing accidents. Use the statement number provided at the end of each warning to locate its translation in the translated safety warnings that accompanied this device.

SAVE THESE INSTRUCTIONS

Regulatory: Provided for additional information and to comply with regulatory and customer requirements.

The safety warnings for this product are translated into several languages in the *Regulatory Compliance and Safety Information for the Cisco IE 2000 Switch* that ships with the product. The EMC regulatory statements are also included in that guide.

Related Publications

Before installing, configuring, or upgrading the switch, see the release notes on Cisco.com for the latest information.

These documents provide complete information about the switch and are available on Cisco.com:

- *Cisco IE 2000 Switch Getting Started Guide*
- *Regulatory Compliance and Safety Information for the Cisco IE 2000 Switch*
- *Release Notes for the Cisco IE 2000 Switch*
- *Cisco IE 2000 Switch Software Configuration Guide*
- *Cisco IE 2000 Switch Command Reference*
- *Cisco IE 2000 Switch System Message Guide*
- Device Manager online help (available on the switch)
- *Cisco Small Form-Factor Pluggable Modules Installation Notes*

These compatibility matrix documents are available from this Cisco.com site:

http://www.cisco.com/en/US/products/hw/modules/ps5455/products_device_support_tables_list.html

- *Cisco Gigabit Ethernet Transceiver Modules Compatibility Matrix* (not orderable but available on Cisco.com)
- *Cisco Small Form-Factor Pluggable Modules Compatibility Matrix* (not orderable but available on Cisco.com)

Obtaining Documentation and Submitting a Service Request

For information on obtaining documentation, using the Cisco Bug Search Tool (BST), submitting a service request, and gathering additional information, see [What's New in Cisco Product Documentation](#).

To receive new and revised Cisco technical content directly to your desktop, you can subscribe to the [What's New in Cisco Product Documentation RSS feed](#). The RSS feeds are a free service.



Product Overview

This chapter discusses the following topics:

- [Switch Models, page 8](#)
- [Front Panel Overview, page 10](#)
- [Ports and Slots, page 14](#)
- [Power Connectors, page 17](#)
- [Alarm Connector, page 18](#)
- [SFP Modules, page 19](#)
- [LEDs, page 20](#)
- [Flash Memory Card, page 25](#)
- [Rear Panel, page 25](#)
- [Management Options, page 26](#)
- [Network Configurations, page 27](#)

Overview

This switch provides a rugged and secure switching infrastructure for harsh environments. It is suitable for industrial Ethernet applications, including factory automation, intelligent transportation systems (ITSs), substations, oil and gas installations, and other deployments in harsh environments.

You can connect this switch to office networking devices such as Cisco IP phones, Cisco Wireless Access Points workstations, and other devices such as servers, routers, and other switches. In industrial environments, you can connect any Ethernet-enabled industrial communication devices, including programmable logic controllers (PLCs), human-machine interfaces (HMIs), drives, sensors, video devices, traffic signal controllers, and intelligent electronic devices (IEDs).

You can mount the switch on a DIN rail in an industrial enclosure. Its components are designed to withstand extremes in temperature, vibration, and shock common to industrial environments.

Switch Models

Table 1 on page 8 describes the switch models.

Table 1 Switch Descriptions

Model	Description	Software Image
Cisco IE-2000-4S-TS-G-B	4 10/100BASE-TX SFP module downlink slots 2 Gigabit Ethernet SFP uplink slots	LAN Base
Cisco IE-2000-4S-TS-G-L	4 10/100BASE-TX SFP module downlink slots 2 Gigabit Ethernet SFP uplink slots	LAN Lite
Cisco IE-2000-4T-B	4 10/100BASE-T downlink ports 2 10/100BASE-T uplink ports	LAN Base
Cisco IE-2000-4T-G-B	4 10/100BASE-T downlink ports 2 10/100/1000BASE-T uplink ports	LAN Base
Cisco IE-2000-4T-G-L	4 10/100BASE-T downlink ports 2 10/100/1000BASE-T uplink ports	LAN Lite
Cisco IE-2000-4T-L	4 10/100BASE-T downlink ports 2 10/100BASE-T uplink ports	LAN Lite
Cisco IE-2000-4TS-B	4 10/100BASE-T Ethernet ports 2 100 Mb/s SFP module uplink slots	LAN Base
Cisco IE-2000-4TS-G-B	4 10/100BASE-T downlink ports 2 100/1000 Mb/s SFP module uplink slots	LAN Base
Cisco IE-2000-4TS-G-L	4 10/100BASE-T downlink ports 2 100/1000 Mb/s SFP module uplink slots	LAN Lite
Cisco IE-2000-4TS-L	4 10/100BASE-T downlink ports 2 100 Mb/s SFP (small form-factor pluggable) module uplink slots	LAN Lite
Cisco IE-2000-8TC-B	8 10/100BASE-T downlink ports 2 Fast Ethernet dual-purpose uplink ports	LAN Base
Cisco IE-2000-8TC-L	8 10/100BASE-T downlink ports 2 Fast Ethernet dual-purpose uplink ports	LAN Lite
Cisco IE-2000-8TC-G-B	8 10/100BASE-T downlink ports 2 Gigabit Ethernet dual-purpose uplink ports	LAN Base
Cisco IE-2000-8TC-G-E	8 10/100BASE-T downlink ports 2 Gigabit Ethernet dual-purpose uplink ports Supports the IEEE-1588 standard for synchronizing clocks. Can enable Network Address Translation (NAT) by license upgrade.	LAN Base with 1588
Cisco IE-2000-8TC-G-L	8 10/100BASE-T downlink ports 2 Gigabit Ethernet dual-purpose uplink ports	LAN Lite

Table 1 Switch Descriptions (continued)

Model	Description	Software Image
Cisco IE-2000-8TC-G-N	<p>8 10/100BASE-T downlink ports</p> <p>2 Gigabit Ethernet dual-purpose uplink ports</p> <p>Supports the IEEE-1588 standard for synchronizing clocks and NAT.</p>	LAN Base with 1588 and NAT
Cisco IE-2000-16PTC-G-E	<p>12 10/100BASE-T downlink ports</p> <p>2 Gigabit Ethernet dual-purpose uplink ports</p> <p>4 Power over Ethernet (PoE) ports</p> <p>Note: The four PoE ports can operate as PoE or PoE+ if provided sufficient external power source.</p> <p>Supports the IEEE-1588 standard for synchronizing clocks.</p> <p>Can enable NAT by license upgrade.</p>	LAN Base with 1588
Cisco IE-2000-16PTC-G-L	<p>12 10/100BASE-T downlink ports</p> <p>2 Gigabit Ethernet dual-purpose uplink ports</p> <p>4 Power over Ethernet (PoE) ports</p> <p>Note: The four PoE ports can operate as PoE or as PoE+ if provided sufficient external power source.</p>	LAN Lite
Cisco IE-2000-16PTC-G-NX	<p>12 10/100BASE-T downlink ports</p> <p>2 Gigabit Ethernet dual-purpose uplink ports</p> <p>4 Power over Ethernet (PoE) ports</p> <p>Note: The four PoE ports can operate as PoE or as PoE+ if provided sufficient external power source.</p> <p>Supports the IEEE-1588 standard for synchronizing clocks and NAT.</p>	LAN Base with 1588 and conformal coat
Cisco IE-2000-16TC-B	<p>16 10/100BASE-T downlink ports</p> <p>2 Fast Ethernet dual-purpose uplink ports</p> <p>2 100 Mb/s SFP module uplink slots</p>	LAN Base
Cisco IE-2000-16TC-G-E	<p>16 10/100BASE-T downlink ports</p> <p>2 Gigabit Ethernet dual-purpose uplink ports</p> <p>2 100 Mb/s SFP module uplink slots</p> <p>Supports the IEEE-1588 standard for synchronizing clocks.</p> <p>Can enable NAT by license upgrade.</p>	LAN Base with 1588
Cisco IE-2000-16TC-G-L	<p>16 10/100BASE-T downlink ports</p> <p>2 Gigabit Ethernet dual-purpose uplink ports</p> <p>2 100 Mb/s SFP module uplink slots</p>	LAN Lite

Table 1 Switch Descriptions (continued)

Model	Description	Software Image
Cisco IE-2000-16TC-G-N	16 10/100BASE-T downlink ports 2 Gigabit Ethernet dual-purpose uplink ports Supports the IEEE-1588 standard for synchronizing clocks and NAT.	LAN Base with 1588 and NAT
Cisco IE-2000-16TC-G-X	16 10/100BASE-T downlink ports 2 Gigabit Ethernet uplink ports 2 100 Mb/s SFP module uplink slots Supports the IEEE-1588 standard for synchronizing clocks. Can enable NAT by license upgrade.	LAN Base with 1588 and conformal coat
Cisco IE-2000-16TC-L	16 10/100BASE-T downlink ports 2 Fast Ethernet dual-purpose uplink ports 2 100 Mb/s SFP module uplink slots	LAN Lite

Front Panel Overview

This section describes the front panel components:

- 4, 8, or 16 10/100BASE-T Ethernet ports
- 10/100/1000 uplink ports (available on some models, see [Table 1 on page 8](#))
- Dual-purpose ports (available on some models, see [Table 1 on page 8](#))
- SFP module slots (available on some models, see [Table 1 on page 8](#))
- RJ-45 console port
- USB mini-Type B (console) port
- LEDs
- Power connectors
- Alarm connector
- Flash memory card slot

All IE 2000 switches have similar components, as shown in [Figure 1 on page 11](#), [Figure 2 on page 12](#), [Figure 3 on page 13](#), and [Figure 4 on page 14](#).

Figure 1 Cisco IE-2000-4S-TS-G-B Front Panel View

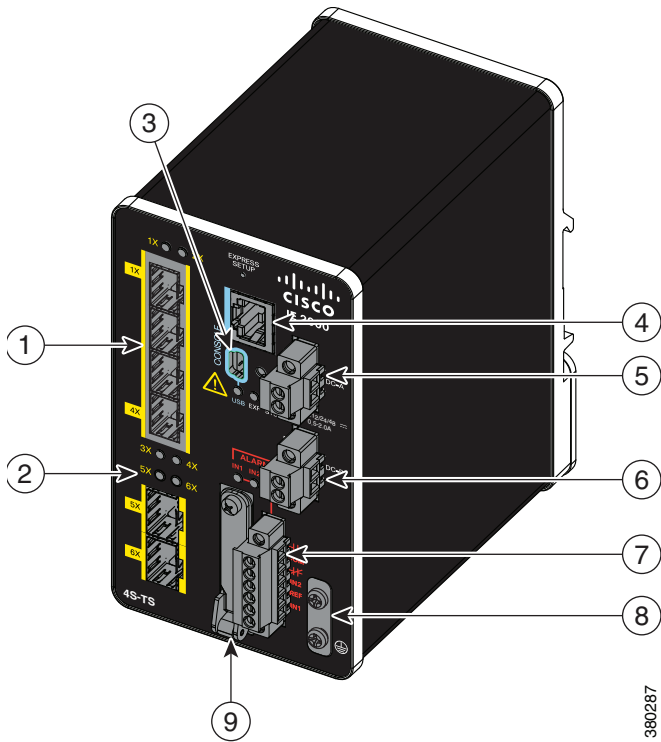

- | | |
|---|---------------------------------------|
| 1 SFP module slots (downlink ports) | 6 Power connector DC-B ² |
| 2 SFP module slots (uplink ports) | 7 Alarm connector |
| 3 USB mini-Type B (console) port ¹ | 8 Protective ground connection |
| 4 RJ-45 console port | 9 Flash memory card slot ¹ |
| 5 Power connector DC-A ² | |

¹ Use a screwdriver to remove the port cover and access the port.

² Remove the plastic cover to access the power connector.

Figure 2 Cisco IE-2000-8TC-L Front Panel View

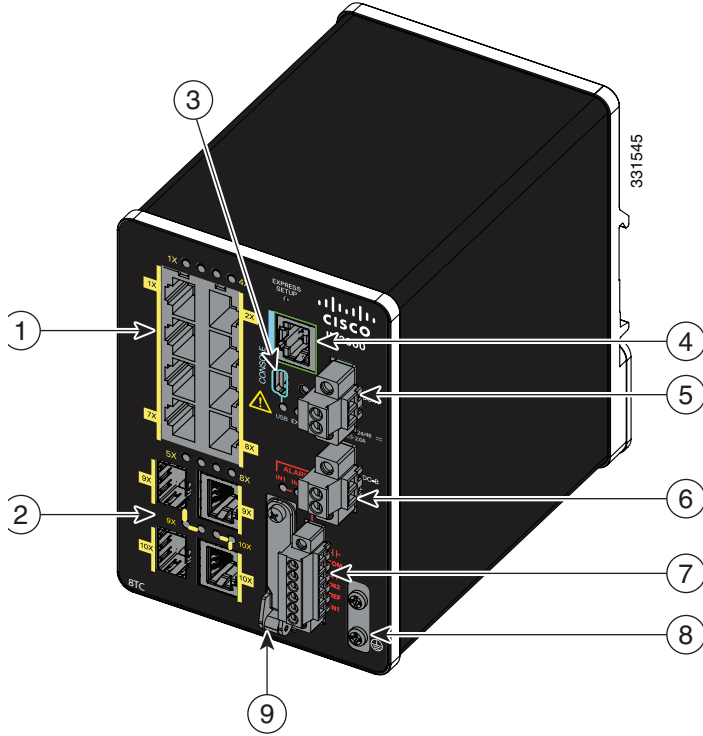

- | | | | |
|---|---|---|-------------------------------------|
| 1 | 10/100 Ethernet ports (downlink ports) | 6 | Power connector DC-B ² |
| 2 | Dual-purpose ports (uplink ports) | 7 | Alarm connector |
| 3 | USB mini-Type B (console) port ¹ | 8 | Protective ground connection |
| 4 | RJ-45 console port | 9 | Flash memory card slot ¹ |
| 5 | Power connector DC-A ² | | |

¹ Use a screwdriver to remove the port cover and access the port.

² Remove the plastic cover to access the power connector.

Figure 3 Cisco IE-2000-16TC-L Front Panel View

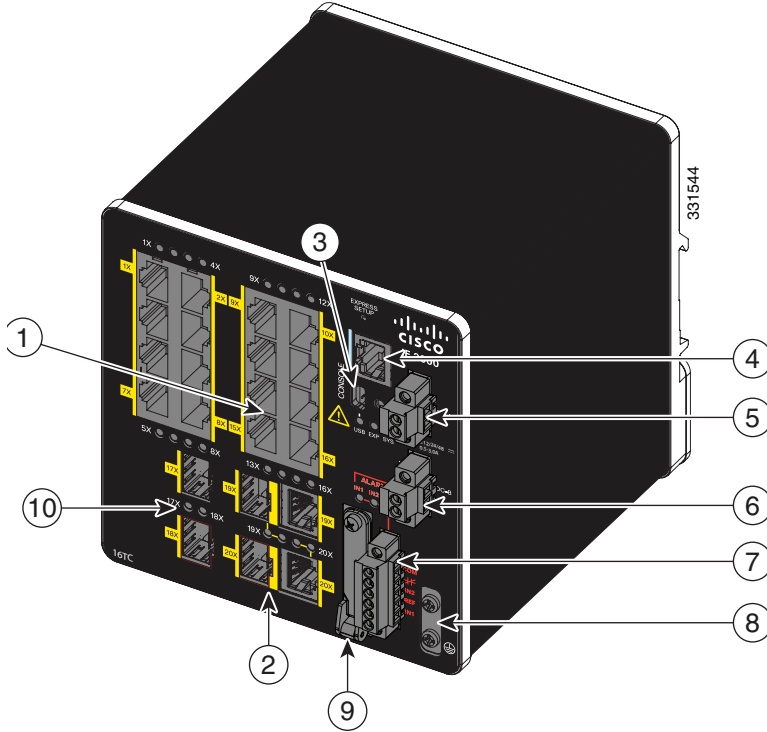

- | | |
|---|---------------------------------------|
| 1 10/100 Ethernet ports (downlink ports) | 6 Power connector DC-B ² |
| 2 Dual-purpose ports (uplink ports) | 7 Alarm connector |
| 3 USB mini-Type B (console) port ¹ | 8 Protective ground connection |
| 4 RJ-45 console port | 9 Flash memory card slot ¹ |
| 5 Power connector DC-A ² | 10 SFP module slots (uplink ports) |

¹ Use a screwdriver to remove the port cover and access the port.

² Remove the plastic cover to access the power connector.

Figure 4 Cisco IE-2000-16PTC-G-E Front Panel View

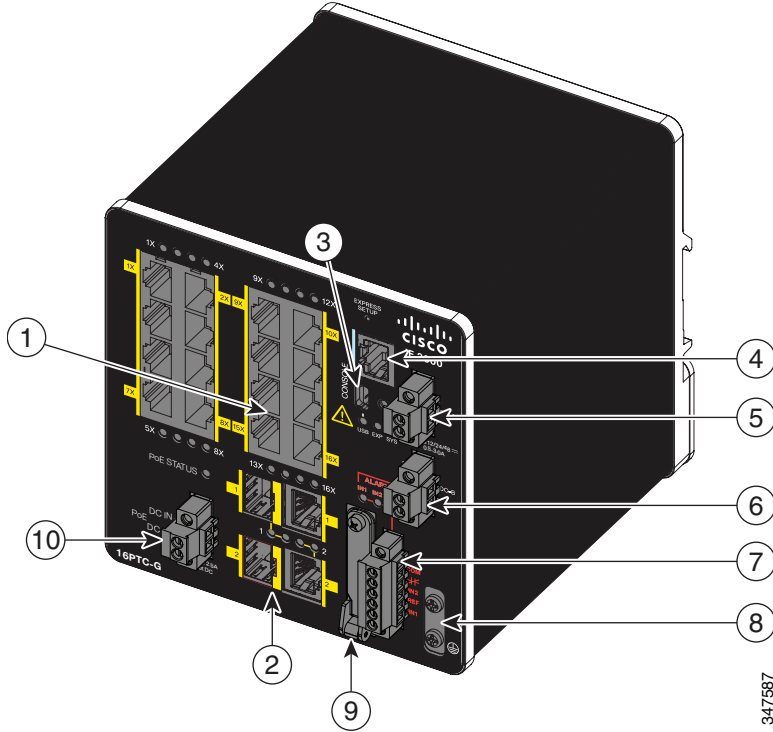

- | | | | |
|---|---|----|-------------------------------------|
| 1 | 10/100 Ethernet ports (downlink ports) | 6 | Power connector DC-B ² |
| 2 | Dual-purpose ports (uplink ports) | 7 | Alarm connector |
| 3 | USB mini-Type B (console) port ¹ | 8 | Protective ground connection |
| 4 | RJ-45 console port | 9 | Flash memory card slot ¹ |
| 5 | Power connector DC-A ² | 10 | PoE power connector |

¹ Use a screwdriver to remove the port cover and access the port.

² Remove the plastic cover to access the power connector.

Ports and Slots

- [10/100BASE-T Downlink Ports, page 15](#)
- [10/100BASE-T Uplink Ports, page 15](#)
- [10/100/1000BASE-T Uplink Ports, page 15](#)
- [100 Mb/s SFP Module Downlink Slots, page 15](#)
- [100/1000 Mb/s SFP Module Uplink Slots, page 15](#)
- [Dual-Purpose Fast Ethernet Uplink Ports, page 15](#)
- [Dual-Purpose Gigabit Ethernet Uplink Ports, page 16](#)
- [Power over Ethernet Ports, page 16](#)
- [Management Ports, page 16](#)

10/100BASE-T Downlink Ports

You can set the 10/100BASE-T downlink ports to operate at 10 or 100 Mb/s in full-duplex or half-duplex mode. You can also set these ports for speed and duplex autonegotiation in compliance with IEEE 802.3AB. (The default setting is autonegotiate.) When set for autonegotiation, the port senses the speed and duplex settings of the attached device and advertises its own capabilities. If the connected device also supports autonegotiation, the switch port negotiates the best connection (that is, the fastest line speed that both devices support, and full-duplex transmission if the attached device supports it) and configures itself accordingly. In all cases, the attached device must be within 328 feet (100 meters). 100BASE-TX traffic requires CAT5 cable. 10BASE-T traffic can use Category 3 or Category 4 cables.

When connecting the switch to workstations, servers, routers, and Cisco IP phones, make sure that the cable is a straight-through cable.

You can use the **mdix auto** interface configuration command in the command-line interface (CLI) to enable the automatic medium-dependent interface crossover (auto-MDIX) feature. When the auto-MDIX feature is enabled, the switch detects the required cable type for copper Ethernet connections and configures the interfaces accordingly. For configuration information for this feature, see the switch software configuration guide or the switch command reference.

10/100BASE-T Uplink Ports

The IEEE 802.3u 10/100BASE-T uplink ports provide full-duplex 10, 100 Mb/s connectivity over CAT5 unshielded twisted pair (UTP) copper cabling. The default setting is autonegotiate. The cable can be up to 100 m (0.1 km) in length.

10/100/1000BASE-T Uplink Ports

The IEEE 802.3u 10/100/1000BASE-T uplink ports provide full-duplex 10, 100 or 1000 Mb/s connectivity over CAT5 unshielded twisted pair (UTP) copper cabling. The default setting is autonegotiate. The cable can be up to 100 m (0.1 km) in length.

100 Mb/s SFP Module Downlink Slots

The IEEE 802.3u 100 Mb/s SFP module downlink slots provide full-duplex 100 Mb/s connectivity over multi-mode (MM) fiber cables or single-mode (SM) fiber cables. These ports use a SFP fiber-optic transceiver module that accepts a dual local connector (LC). Check the [SFP Module Cables, page 90](#) for the cable type and length.

100/1000 Mb/s SFP Module Uplink Slots

The IEEE 802.3u 100 Mb/s SFP module uplink slots provide full-duplex 100 or 1000 Mb/s connectivity over multi-mode fiber (MMF) or single-mode fiber (SMF) cables, or CAT5 (or later) cables. These ports use a SFP fiber-optic transceiver module that accepts a dual LC connector. See [SFP Module Cables, page 90](#) for cable type and length.

10/100/1000BASE-T Copper SFP Module Uplink Slots

The IEEE 802.3 1000BASE-T copper SFP module slots provide full-duplex 1000Base-T connectivity over copper wire. These ports use a copper SFP transceiver module that accepts an RJ-45 connector. See [SFP Module Cables, page 90](#) for cable type and length.

Dual-Purpose Fast Ethernet Uplink Ports

You can configure the dual-purpose Fast Ethernet uplink ports on the switch as either 10/100BASE-T ports or as 100 Mb/s SFP-module ports. You can set the 10/100 ports to autonegotiate, or you can configure them as fixed 10 or 100 Mb/s ports.

By default, the switch selects the medium for each dual-purpose port (10/100BASE-T or SFP). When a link is achieved on one media type, the switch disables the other media type until the active link goes down. If links are active on both media, the SFP-module port has priority, but you can use the **media-type** interface configuration command to manually designate the port as an RJ-45 port or an SFP port.

You can configure the speed and duplex settings consistent with the selected media type. For information on configuring interfaces, see the switch software configuration guide.

Dual-Purpose Gigabit Ethernet Uplink Ports

You can configure the dual-purpose Gigabit Ethernet uplink ports on the switch as either 10/100/1000BASE-T ports or as 100/1000 Mb/s SFP-module ports. You can set the 10/100/1000BASE-T ports to autonegotiate, or you can configure them as fixed 10, 100, or 1000 Mb/s (Gigabit) Ethernet ports.

By default, the switch selects the medium for each dual-purpose port (10/100/1000BASE-T or SFP). When a link is achieved on one media type, the switch disables the other media type until the active link goes down. If links are active on both media, the SFP-module port has priority, but you can use the **media-type** interface configuration command to manually designate the port as an RJ-45 port or an SFP port.

You can configure the speed and duplex settings consistent with the selected media type. For information on configuring interfaces, see the switch software configuration guide.

Power over Ethernet Ports

On certain models of the IE 2000 switch, four of the 10/100BASE-T ports are available as PoE ports. The four ports can operate as PoE (IEEE 802.3af) ports or can be configured to operate as PoE+ (IE 802.at) ports. Each PoE port requires 15.4 Watts of power while PoE+ requires 30 Watts. A 54VDC /1.2Amp power source (65W) can support 4 PoE ports or 2 PoE+ ports.

Cable lengths of up to 328 ft (100 m) are supported.

Management Ports

You can connect the switch to a PC running Microsoft Windows or to a terminal server through either the RJ-45 console port or the USB mini-Type B console port, also referred to as the USB-mini console port. These ports use the following connectors:

- RJ-45 console port uses an RJ-45-to-DB-9 female cable.
- USB-mini console port (5-pin connector) uses a USB Type A-to-5-pin mini-Type B cable.

The USB-mini console interface speeds are the same as the RJ-45 console interface speeds.

To use the USB-mini console port, you must install the Cisco Windows USB device driver on the device that is connected to the USB-mini console port and that is running Microsoft Windows.

Note: For information about downloading the Cisco USB device driver, see [Installing the Cisco Microsoft Windows XP, 2000, Vista, 7, 8, and 10 USB Device Driver, page 105](#).

With the Cisco Windows USB device driver, connecting and disconnecting the USB cable from the console port does not affect Windows HyperTerminal operations. Mac OS X or Linux require no special drivers.

Note: The 5-pin mini-Type B connectors resemble the 4-pin mini-Type B connectors, but they are not compatible. Use only the 5-pin mini-Type B. See [Figure 5 on page 17](#).

Figure 5 USB Mini-Type B Port

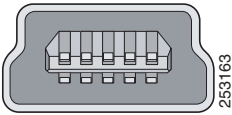

The configurable inactivity timeout reactivates the RJ-45 console port if the USB-mini console port is activated, but no input activity occurs for a specified time period. When the USB-mini console port deactivates due to a timeout, you can restore its operation by disconnecting and reconnecting the USB cable. For information on using the CLI to configure the USB-mini console interface, see the switch software guide.

Power Connectors

- [DC Power Connector, page 17](#)
- [PoE Power Connector, page 17](#)

DC Power Connector

You connect the DC power to the switch through the front panel connectors. The switch has a dual-feed DC power supply; two connectors provide primary and secondary DC power (DC-A and DC-B). The DC power connectors are near the top right of the front panel (see [Figure 2 on page 12](#)). Each power connector has an LED status indicator.

The switch power connectors are attached to the switch chassis. Each power connector has screw terminals for terminating the DC power (see [Figure 6 on page 17](#)). All connectors are attached to the switch front panel with the provided captive screws.

The power connector labeling is on the panel. The positive DC power connection is labeled “+”, and the return connection is labeled “-”.

Figure 6 Power Connector

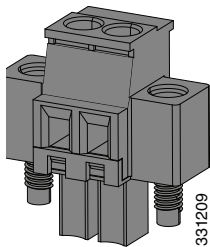

The switch can operate with a single power source or with dual power sources. When both power sources are operational, the switch draws power from the DC source with the higher voltage. If one of the two power sources fail, the other continues to power the switch.

PoE Power Connector

The IE 2000 switch models with PoE capability (IE-2000-16PTC-G-E, IE-2000-16PTC-G-L, and IE-2000-16PTC-G-NX) are equipped with an additional DC input terminal block. This DC terminal block allows the connection of a second power supply (see [Power over Ethernet Ports, page 16](#)), or a second input from site source DC power to operate the PoE ports. The PoE terminal block accepts 48 VDC or 54 VDC at 2.5 A.

Alarm Connector

You connect the alarm signals to the switch through the alarm connector. The switch supports two alarm inputs and one alarm output relay. The alarm connector is on the bottom right of the front panel. See [Figure 3 on page 13](#).

The alarm connector provides six alarm wire connections. The connector is attached to the switch front panel with the provided captive screws.

Figure 7 Alarm Connector

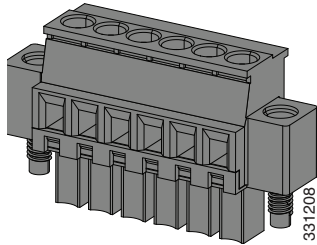

Both alarm input circuits can sense if the alarm input is open or closed. The alarm inputs can be activated for environmental, power supply, and port status alarm conditions. From the CLI, you can configure each alarm input as an open or closed contact.

The alarm output circuit is a relay with a normally open and a normally closed contact. The switch is configured to detect faults that are used to energize the relay coil and change the state on both of the relay contacts: normally open contacts close, and normally closed contacts open. The alarm output relay can be used to control an external alarm device, such as a bell or a light.

See the switch software configuration guide for instructions on configuring the alarm relays.

For more information about the alarm connector, see [Cable and Connectors, page 87](#).

SFP Modules

The switch Ethernet SFP modules provide connections to other devices. These field-replaceable transceiver modules provide the uplink interfaces. LC connectors provide fiber-optic connections; RJ-45 connectors for copper connections. You can use any combination of the supported SFP modules listed in [Table 2 on page 19](#).

Table 2 SFP Module Maximum Operating Temperature by Model

SFP Module	Model
Rugged and Industrial SFPs -40 to 185° F (-40 to 85° C)	<ul style="list-style-type: none"> ■ GLC-SX-MM-RGD ■ GLC-LX-SM-RGD ■ GLC-FE-100LX-RGD ■ GLC-FE-100FX-RGD ■ GLC-FE-T-I ■ GLC-ZX-SM-RGD ■ GLC-BX40-D-I with digital optical monitoring (DOM) support ■ GLC-BX40-DA-I with DOM support ■ GLC-BX80-D-I with DOM support ■ GLC-BX40-U-I with DOM support ■ GLC-BX80-U-I with DOM support
Commercial SFPs 32 to 158° F (0 to 70° C)	<ul style="list-style-type: none"> ■ GLC-BX-D with DOM support ■ GLC-BX-U with DOM support ■ GLC-FE-100LX ■ GLC-FE-100BX-D ■ GLC-FE-100BX-U ■ GLC-FE-100FX ■ GLC-FE-100EX ■ GLC-FE-100ZX ■ GLC-T ■ CWDM with DOM support ■ DWDM with DOM support

Table 2 SFP Module Maximum Operating Temperature by Model (continued)

SFP Module	Model
Extended temperature SFPs 23 to 185° F (-5° C to 85° C)	<ul style="list-style-type: none">■ SFP-GE-L with DOM support■ SFP-GE-S with DOM support■ SFP-GE-T■ SFP-GE-Z with DOM support■ GLC-LH-SMD with DOM support■ GLC-EX-SMD with DOM support■ GLC-SX-MMD with DOM support■ GLC-TE■ GLC-ZX-SMD with DOM support

For minimum software requirements, refer to the Release Notes for your platform.

For an up-to-date list of supported SFP models for Cisco Industrial Ethernet switches, see http://www.cisco.com/en/US/docs/interfaces_modules/transceiver_modules/compatibility/matrix/OL_6981.html#wp138176

For installation instructions, see your SFP module documentation and the [Installing and Removing SFP Modules, page 66](#). For cable specifications, see [SFP Module Cables, page 90](#).

SFP Module Patch Cable

The switch uses an SFP-module patch cable, a 0.5-meter, copper, passive cable with SFP module connectors at each end (see [Figure 8 on page 20](#)). The patch cable connects two switches in a cascaded configuration.

Figure 8 SFP-Module Patch Cable

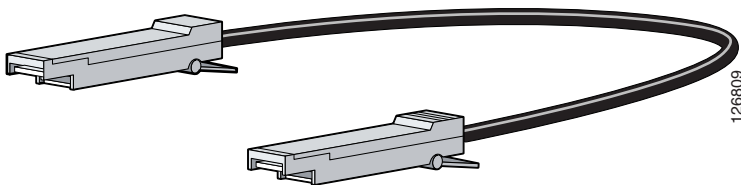

See [Installing and Removing SFP Modules, page 66](#) for information about using the SFP module patch cable.

You can order this cable (part number CAB-SFP-50CM=).

LEDs

You can use the LEDs to monitor the switch status, activity, and performance. [Figure 9 on page 21](#) and [Table 9 on page -24](#) show the front panel LEDs.

Figure 9 LEDs on the Cisco IE 2000 Switch

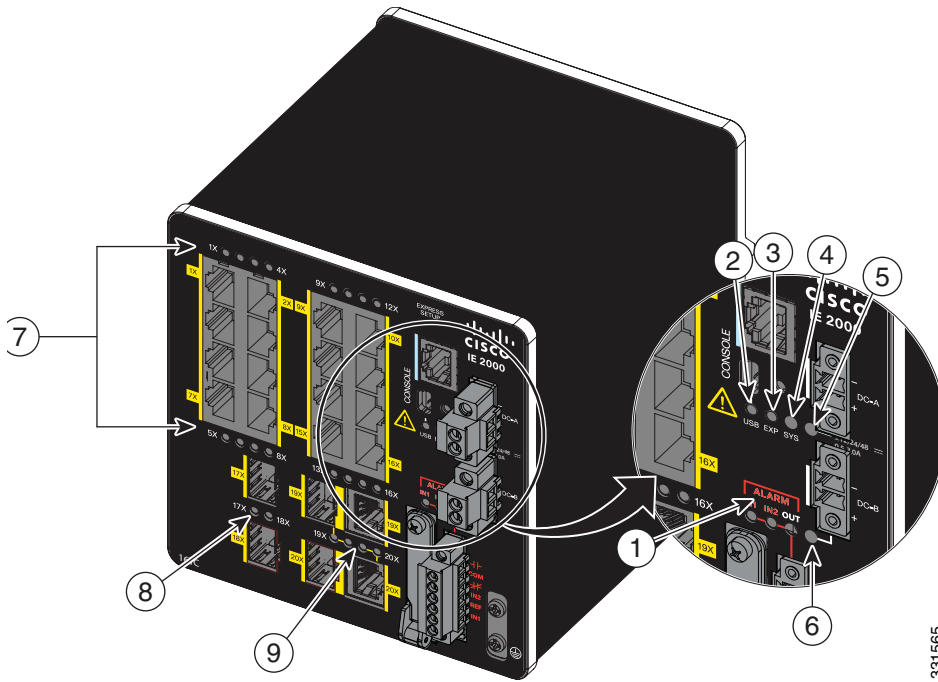

- | | |
|--------------------------------------|-----------------------------------|
| 1 Alarm LEDs | 6 Power connector DC-B LED |
| 2 USB mini-Type B (console) port LED | 7 10/100BASE-T downlink port LEDs |
| 3 Express Setup LED | 8 SFP module slot LEDs |
| 4 System LED | 9 Dual-purpose uplink port LEDs |
| 5 Power connector DC-A LED | |

Note: On IE 2000 switches with PoE support, the two SFP ports and the associated LEDs are replaced by a PoE DC-input terminal block and a PoE LED. For more information, see [PoE Status LED, page 24](#).

Express Setup LED

The Express Setup LED displays the express setup mode for the initial configuration.

Table 3 Express Setup LED

Color	Setup Status
Off (dark)	Switch is configured as a managed switch.
Solid green	Switch is operating normally.
Blinking green	Switch is in initial setup, in recovery, or initial setup is incomplete.
Solid red	Switch failed to start initial setup or recovery because there is no available switch port to which to connect the management station. Disconnect a device from a switch port, and then press the Express Setup button.

System LED

The System LED shows whether the system is receiving power and is functioning properly.

Table 4 System LED

Color	System Status
Off	System is not powered on.
Blinking green	Boot fast is in progress.
Green	System is operating normally.
Red	Switch is not functioning properly.

USB-Mini Console LED

The USB-mini console LED shows which console port is in use. See [Figure 9 on page 21](#) for the LED location. If you connect a cable to a console port, the switch automatically uses that port for console communication. If you connect two console cables, the USB-mini console port has priority.

Table 5 USB-Mini Console LED

Color	Description
Green	USB-mini console port is active. RJ-45 console port LED is not active.
Off	Port is not active. RJ-45 console port is active.

Alarm LEDs

[Table 6 on page -22](#) and [Table 7 on page -22](#) list the alarm LED colors and their meanings.

Table 6 Alarm OUT LED

Color	System Status
Off	Alarm OUT is not configured, or the switch is off.
Green	Alarm OUT is configured, no alarm detected.
Blinking red	Switch has detected a major alarm.
Red	Switch has detected a minor alarm.

Table 7 Alarm IN1 and IN2 Status LEDs

Color	System Status
Off	Alarm IN1 or IN2 not configured.
Green	Alarm IN1 or IN2 configured, no alarm detected.
Blinking red	Major alarm detected.
Red	Minor alarm detected.

Power Status LEDs

The switch can operate with one or two DC power sources. Each DC input has an associated LED that shows the status of the corresponding DC input. If power is present on the circuit, the LED is green. If power is not present, the LED color depends on the alarm configuration. If alarms are configured, the LED is red when power is not present; otherwise, the LED is off.

If the switch has dual power sources, the switch draws power from the power source with the higher voltage. If one of the DC sources fails, the alternate DC source powers the switch, and the corresponding power status LED is green. The power status for the failed DC source is either off or red, depending on the alarm configuration.

Table 8 Power Status LEDs

Color	System Status
Green	Power is present on the associated circuit, system is operating normally.
Off	Power is not present on the circuit, or the system is not powered up.
Red	Power is not present on the associated circuit, and the power supply alarm is configured.

The Power A and Power B LEDs show that power is not present on the switch if the power input drops below the low valid level. The power status LEDs only show that power is present if the voltage at the switch input exceeds the valid level.

For information about the power LED colors during the boot fast sequence, see [Verifying Switch Operation, page 73](#).

Port Status LEDs

Each port and SFP uplink slot has a status LED, as shown in [Figure 9 on page 21](#) and [Figure 10 on page 24](#).

Table 9 Port Status LEDs

Color	System Status
Off	No link.
Solid green	Link present.
Blinking green	Activity. Port is sending or receiving data.
Alternating green-amber	Link fault. Error frames can affect connectivity, and errors such as excessive collisions, CRC errors, and alignment and jabber errors are monitored for a link-fault indication.
Solid amber	Port is not forwarding. The port was disabled by management, an address violation, or STP. Note: After a port is reconfigured, the port LED can remain amber for up to 30 seconds while STP checks the switch for possible loops.

Dual-Purpose Port LEDs

[Figure 10 on page 24](#) shows the LEDs on a dual-purpose port. The LEDs show how the port is being used (Ethernet or SFP module). The LED colors have the same meanings as for the [Port Status LEDs, page 23](#).

Figure 10 Dual-Purpose Port LEDs

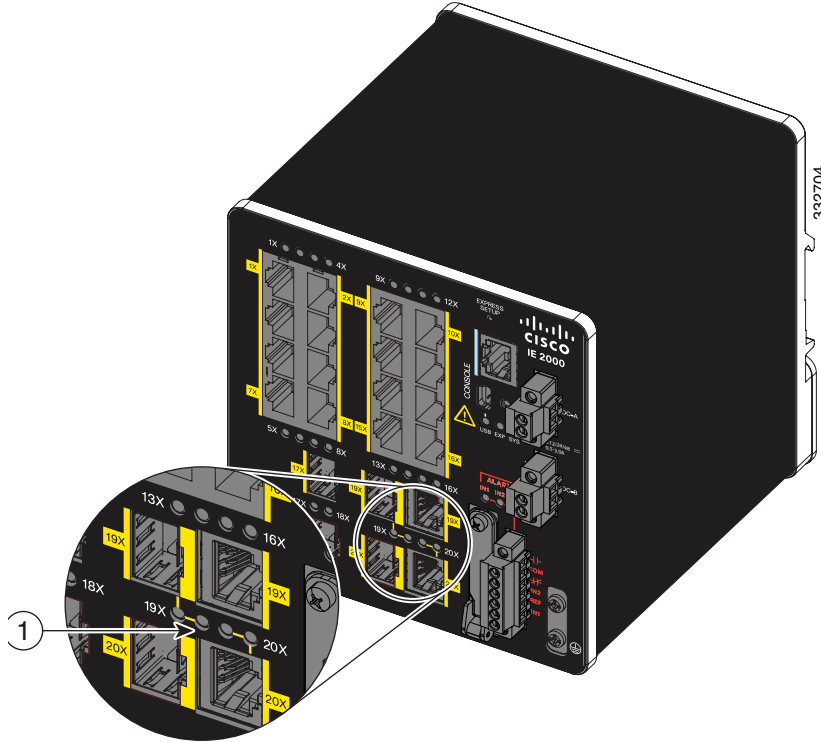

1 Dual-purpose port LEDs

PoE Status LED

The PoE STATUS LED is located on the front panel of the IE 2000 switch models that are equipped with PoE ports. The LED displays the functionality and status of the PoE ports.

Table 10 PoE Status LED

Color	PoE Status
Off	PoE is off. If the powered device is receiving power from a non-PoE power source, the port LED is off even if the powered device is connected to the switch port.
Green	PoE is on. The port LED is green only when the PoE port is providing power.
Alternating green and amber	PoE is denied because providing power to the powered device will exceed the switch power capacity.
Flashing amber	PoE is off due to a fault. Caution: Non-compliant cabling or powered devices can cause a PoE port fault. Use only standard-compliant cabling to connect Cisco pre-standard IP Phones and wireless access points or IEEE 802.3af-compliant devices. You must remove any cable or device that causes a PoE fault.
Amber	PoE for the port is disabled. (PoE is enabled by default.)

Flash Memory Card

The switch supports a flash memory card that makes it possible to replace a failed switch without reconfiguring the new switch. The slot for the flash memory card is on the front of the switch. The flash card is hot swappable and can be accessed on the front panel. A cover protects the flash card and holds the card firmly in place. The cover is hinged and closed with a captive screw. This prevents the card from coming loose and protects against shock and vibration.

For more information on inserting and removing the flash memory card, see [Installing or Removing the Flash Memory Card \(Optional\)](#), page 33.

Note: The replacement SD card part number is SD-IE-1GB.

Rear Panel

The rear panel of the switch has a latch for installation on a DIN rail. See [Figure 11 on page 26](#). The latch is spring-loaded to move down to position the switch over a DIN rail and return to the original position to secure the switch to a DIN rail.

Figure 11 Cisco IE 2000 Switch Rear Panel

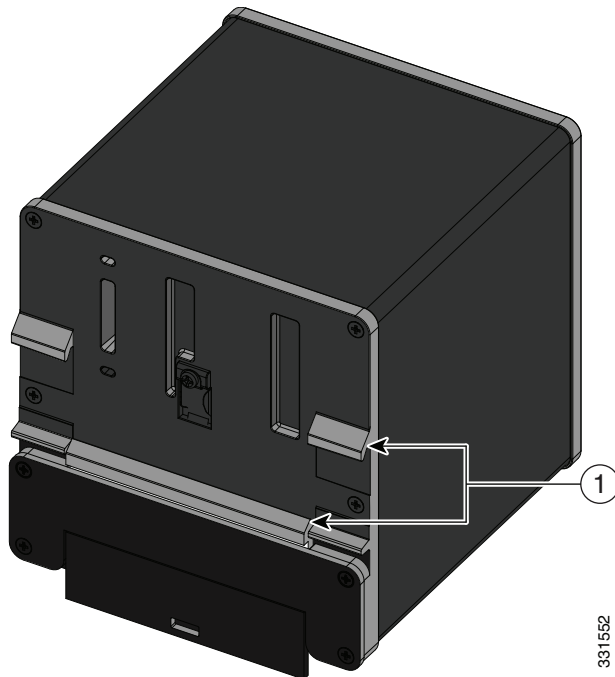

1 Latch

Management Options

The switch supports these management options:

- Cisco Network Assistant

Cisco Network Assistant is a PC-based network management GUI application optimized for LANs of small- and medium-sized businesses. Using the GUI, you can configure and manage switch clusters or standalone switches. Cisco Network Assistant is available at no cost and can be downloaded from this URL:

http://www.cisco.com/en/US/products/ps5931/tsd_products_support_series_home.html

For information on starting the Cisco Network Assistant application, see the *Getting Started with Cisco Network Assistant* guide on Cisco.com.

- Device Manager

You can use Device Manager, which is in the switch memory, to manage individual and standalone switches. This web interface offers quick configuration and monitoring. You can access Device Manager from anywhere in your network through a web browser. For more information, see [Running Express Setup, page 97](#) and the Device Manager online help.

- Cisco IOS CLI

The switch CLI is based on Cisco IOS software and is enhanced to support desktop-switching features. You can fully configure and monitor the switch. You can access the CLI either by connecting your management station directly to the switch management port, or a console port, or by using Telnet from a remote management station. See the switch command reference on Cisco.com for more information.

-
- Cisco Prime LAN Management Solution 4.2

http://www.cisco.com/en/US/docs/net_mgmt/ciscoverworks_lan_management_solution/4.2/device_support/table/ms42sdt.html#Cisco IE 2000 Series Switches

- SNMP network management

You can manage switches from a SNMP-compatible management station that is running platforms such as HP OpenView or SunNet Manager. The switch supports a comprehensive set of Management Information Base (MIB) extensions and four Remote Monitoring (RMON) groups. See the switch software configuration guide on Cisco.com and the documentation that came with your SNMP application for more information.

- Common Industrial Protocol

The Common Industrial Protocol (CIP) management objects are supported. The Cisco IE 2000 can be managed by CIP-based management tools, allowing the user to manage an entire industrial automation system with one tool.

- PROFINET TCP/IP and RT

This switch supports PROFINET TCP/IP and RT and can be managed by Siemens' automation software such as STEP 7.

Network Configurations

See the switch software configuration guide on Cisco.com for network configuration concepts and examples of using the switch to create dedicated network segments and interconnecting the segments through Gigabit Ethernet connections.



Switch Installation

This chapter describes how to install your switch, verify the boot fast, and connect the switch to other devices. It also includes information specifically for installations in hazardous environments.

Read these topics, and perform the procedures in this order:

- [Preparing for Installation, page 29](#)
- [Installing or Removing the Flash Memory Card \(Optional\), page 33](#)
- [Connecting to a Console Port, page 35](#)
- [Connecting to Power, page 39](#)
- [Installing the Switch, page 56](#)
- [Connecting Alarm Circuits, page 59](#)
- [Connecting Destination Ports, page 64](#)
- [Verifying Switch Operation, page 73](#)
- [Where to Go Next, page 73](#)

Preparing for Installation

This section provides information about these topics:

- [Warnings, page 29](#)
- [Additional Information for Installation in a Hazardous Environment, page 30](#)
- [Installation Guidelines, page 32](#)
- [Verifying Package Contents, page 33](#)

Warnings

These warnings are translated into several languages in the *Regulatory Compliance and Safety Information* for this switch.

Warning: Before working on equipment that is connected to power lines, remove jewelry (including rings, necklaces, and watches). Metal objects will heat up when connected to power and ground and can cause serious burns or weld the metal object to the terminals. Statement 43

Warning: Do not work on the system or connect or disconnect cables during periods of lightning activity. Statement 1001

Warning: Before performing any of the following procedures, ensure that power is removed from the DC circuit. Statement 1003

Warning: Read the installation instructions before you connect the system to its power source. Statement 1004

Warning: This unit is intended for installation in restricted access areas. A restricted access area can be accessed only through the use of a special tool, lock and key, or other means of security. Statement 1017

Warning: This equipment must be grounded. Never defeat the ground conductor or operate the equipment in the absence of a suitably installed ground conductor. Contact the appropriate electrical inspection authority or an electrician if you are uncertain that suitable grounding is available. Statement 1024

Warning: This unit might have more than one power supply connection. All connections must be removed to de-energize the unit. Statement 1028

Warning: Only trained and qualified personnel should be allowed to install, replace, or service this equipment. Statement 1030

Warning: Ultimate disposal of this product should be handled according to all national laws and regulations. Statement 1040

Warning: For connections outside the building where the equipment is installed, the following ports must be connected through an approved network termination unit with integral circuit protection. 10/100/1000 Ethernet Statement 1044

Warning: To prevent the system from overheating, do not operate it in an area that exceeds the maximum recommended ambient temperature of: 140° F (60° C) Statement 1047

Warning: Installation of the equipment must comply with local and national electrical codes. Statement 1074

Caution: Airflow around the switch must be unrestricted. To prevent the switch from overheating, there must be the following minimum clearances:

- Top and bottom: 2.0 in. (50.8 mm)
- Sides: 2.0 in. (50.8 mm)
- Front: 2.0 in. (50.8 mm)

Additional Information for Installation in a Hazardous Environment

Hazardous Area Installation Warnings

Warning: Exposure to some chemicals could degrade the sealing properties of materials used in the sealed relay device. Statement 381

Warning: Failure to securely tighten the captive screws can result in an electrical arc if the connector is accidentally removed. Statement 397

Warning: When you connect or disconnect the power and/or alarm connector with power applied, an electrical arc can occur. This could cause an explosion in hazardous area installations. Be sure that all power is removed from the switch and any other circuits. Be sure that power cannot be accidentally turned on or verify that the area is nonhazardous before proceeding. Statement 1058

Warning: In switch installations in a hazardous location, the DC power source could be located away from the vicinity of the switch. Before performing any of the following procedures, locate the DC circuit to ensure that the power is removed and cannot be turned on accidentally, or verify that the area is nonhazardous before proceeding. Statement 1059

Warning: This equipment is supplied as “open type” equipment. It must be mounted within an enclosure that is suitably designed for those specific environmental conditions that will be present and appropriately designed to prevent personal injury resulting from accessibility to live parts. The interior of the enclosure must be accessible only by the use of a tool. The enclosure must meet IP 54 or NEMA type 4 minimum enclosure rating standards. Statement 1063

Warning: When used in a Class I, Division 2, hazardous location, this equipment must be mounted in a suitable enclosure with proper wiring method, for all power, input and output wiring, that complies with the governing electrical codes and in accordance with the authority having jurisdiction over Class I, Division 2 installations. Statement 1066

Warning: Use twisted-pair supply wires suitable for 86° F (30° C) above surrounding ambient temperature outside the enclosure. Statement 1067

Warning: This equipment is intended for use in a Pollution Degree 2 industrial environment, in overvoltage Category II applications (as defined in IEC publication 60664-1), and at altitudes up to 2000 meters without derating. Statement 1068

Warning: Do not connect or disconnect cables to the ports while power is applied to the switch or any device on the network because an electrical arc can occur. This could cause an explosion in hazardous location installations. Be sure that power is removed from the switch and cannot be accidentally be turned on, or verify that the area is nonhazardous before proceeding. Statement 1070

Warning: If you connect or disconnect the console cable with power applied to the switch or any device on the network, an electrical arc can occur. This could cause an explosion in hazardous location installations. Be sure that power is removed or the area is nonhazardous before proceeding. Statement 1080

Warning: Explosion Hazard—Do not connect or disconnect wiring while the field-side power is on; an electrical arc can occur. This could cause an explosion in hazardous location installations. Be sure that power is removed or that the area is nonhazardous before proceeding. Statement 1081

Warning: Explosion Hazard—The area must be known to be nonhazardous before installing, servicing, or replacing the unit. Statement 1082

Warning: Explosion Hazard—Substitution of components may impair suitability for Class I, Division 2/Zone 2. Statement 1083

Warning: Do not insert and remove SFP modules while power is on; an electrical arc can occur. This could cause an explosion in hazardous location installations. Be sure that power is removed or the area is nonhazardous before proceeding. Statement 1087

Caution: This equipment is only suitable for use in Class I, Division 2, Groups A, B, C, D, or nonhazardous locations.

North American Hazardous Location Approval

The following information applies when operating this equipment in hazardous locations:

English: Products marked "Class I, Div 2, GP A, B, C, D" are suitable for use in Class I Division 2 Groups A, B, C, D, Hazardous Locations and nonhazardous locations only. Each product is supplied with markings on the rating nameplate indicating the hazardous location temperature code. When combining products within a system, the most adverse temperature code (lowest "T" number) may be used to help determine the overall temperature code of the system. Combinations of equipment in your system are subject to investigation by the local Authority Having Jurisdiction at the time of installation.

Français: Informations sur l'utilisation de cet équipement en environnements dangereux:

Les produits marqués "Class I, Div 2, GP A, B, C, D" ne conviennent qu'à une utilisation en environnements de Classe I Division 2 Groupes A, B, C, D dangereux et non dangereux. Chaque produit est livré avec des marquages sur sa plaque d'identification qui indiquent le code de température pour les environnements dangereux. Lorsque plusieurs produits sont combinés dans un système, le code de température le plus défavorable (code de température le plus faible) peut être utilisé pour déterminer le code de température global du système. Les combinaisons d'équipements dans le système sont sujettes à inspection par les autorités locales qualifiées au moment de l'installation.

EMC Environmental Conditions for Products Installed in the European Union

This section applies to products to be installed in the European Union.

The equipment is intended to operate under the following environmental conditions with respect to EMC:

- A separate defined location under the user's control.
- Earthing and bonding shall meet the requirements of ETS 300 253 or CCITT K27.
- AC-power distribution shall be one of the following types, where applicable: TN-S and TN-C as defined in IEC 364-3.

In addition, if equipment is operated in a domestic environment, interference could occur.

Installation Guidelines

When determining where to place the switch, observe these guidelines.

Environment and Enclosure Guidelines

Review these environmental and enclosure guidelines before installation:

- This equipment is intended for use in a Pollution Degree 2 industrial environment, in overvoltage Category II applications (as defined in IEC publication 60664-1), at altitudes up to 9842 ft (3 km) without derating.
- This equipment is considered Group 1, Class A industrial equipment, according to IEC/CISPR Publication 11. Without appropriate precautions, there may be potential difficulties ensuring electromagnetic compatibility in other environments due to conducted as well as radiated disturbance.
- This equipment is supplied as open-type equipment. It must be mounted within an enclosure that is suitably designed for those specific environmental conditions that will be present and appropriately designed to prevent personal injury resulting from accessibility to live parts. The enclosure must have suitable flame-retardant properties to prevent or minimize the spread of flame, complying with a flame-spread rating of 5VA, V2, V1, V0 (or equivalent) if nonmetallic. The interior of the enclosure must be accessible only by the use of a tool. Subsequent sections of this publication might contain additional information regarding specific enclosure-type ratings that are required to comply with certain product safety certifications.

General Guidelines

Before installation, observe these general guidelines:

Caution: Proper ESD protection is required whenever you handle Cisco equipment. Installation and maintenance personnel should be properly grounded by using ground straps to eliminate the risk of ESD damage to the switch.

Caution: Do not touch connectors or pins on component boards. Do not touch circuit components inside the switch. When not in use, store the equipment in appropriate static-safe packaging.

- If you are responsible for the application of safety-related programmable electronic systems (PES), you need to be aware of the safety requirements in the application of the system and be trained in using the system.
- This product is grounded through the DIN rail to chassis ground. Use zinc-plated yellow-chromate steel DIN rail to assure proper grounding. The use of other DIN rail materials (such as aluminum, plastic, and so on) that can corrode, oxidize, or are poor conductors can result in improper or intermittent grounding. Secure the DIN rail to the mounting surface approximately every 7.8 in. (200 mm), and use end-anchors appropriately.

When determining where to place the switch, observe these guidelines:

- Before installing the switch, first verify that the switch is operational by powering it on and observing boot fast. Follow the procedures in [Verifying Switch Operation, page 73](#).

-
- For 10/100 ports and 10/100/1000 ports, the cable length from a switch to an attached device cannot exceed 328 feet (100 meters).
 - For 100BASE-FX fiber-optic ports, the cable length from a switch to an attached device cannot exceed 6562 ft (2 km).
 - Operating environment is within the ranges listed in [Technical Specifications, page 81](#)
 - Clearance to front and rear panels meets these conditions:
 - Front-panel LEDs can be easily read.
 - Access to ports is sufficient for unrestricted cabling.
 - Front-panel direct current (DC) power connectors and the alarm connector are within reach of the connection to the DC power source.
 - Airflow around the switch must be unrestricted. To prevent the switch from overheating, you must have the following minimum clearances:
 - Top and bottom: 2.0 in. (50.8 mm)
 - Sides: 2.0 in. (50.8 mm)
 - Front: 2.0 in. (50.8 mm)
 - Temperature surrounding the unit does not exceed 140°F (60°C).

Note: When the switch is installed in an industrial enclosure, the temperature within the enclosure is greater than normal room temperature outside the enclosure.

Note: The temperature inside the enclosure cannot exceed 140°F (60°C), the maximum ambient enclosure temperature of the switch.
 - Cabling is away from sources of electrical noise, such as radios, power lines, and fluorescent lighting fixtures.
 - Connect the unit only to a Class 2 DC power source.

Verifying Package Contents

The *Cisco IE 2000 Switch Getting Started Guide* on Cisco.com describes the box contents. If any item is missing or damaged, contact your Cisco representative or reseller for support.

Installing or Removing the Flash Memory Card (Optional)

The software /firmware is stored on the internal flash memory in the Cisco IE2000 switch. Optionally, you can order and install an SD memory card (SD-IE-1GB=) to store the software and the configuration changes. If you need to replace the switch, you can simply insert the SD memory card instead of configuring the new switch.

Warning: Do not insert or remove the flash card while power is on; an electrical arc can occur. This could cause an explosion in hazardous location installations. Be sure that power is removed or the area is nonhazardous before proceeding. Statement 379

To install or replace the flash memory card, follow these steps:

1. On the front of the switch, locate the door that protects the flash memory card slot. Loosen the captive screw at the top of the door using a Phillips screwdriver to open the door. See [Figure 12 on page 34](#).

Figure 12 Installing the Flash Memory Card in the Switch

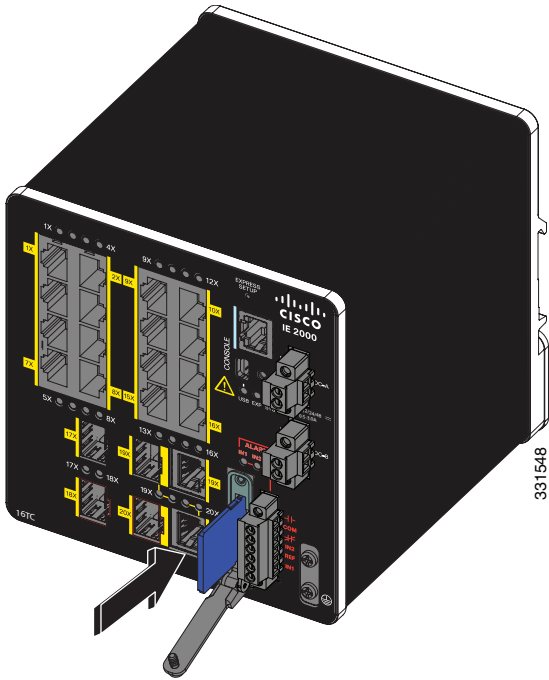
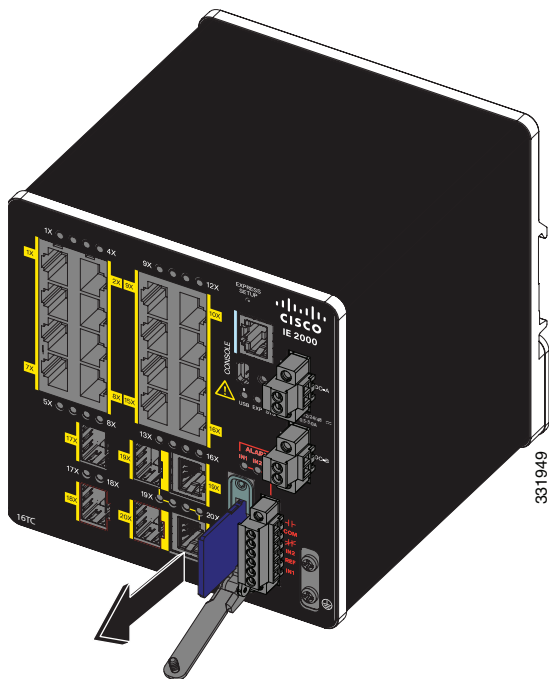

Figure 13 Removing the Flash Memory Card from the Switch



2. Install or remove the card:

- To install a card, slide it into the slot, and press it in until it clicks in place. The card is keyed so that you cannot insert it the wrong way.

-
- To remove the card, push it in until it releases for it to pop out. Place it in an antistatic bag to protect it from static discharge.
3. After the card is installed, close the guard door and fasten the captive screw using a Phillips screwdriver to keep the door in place.

Connecting to a Console Port

You can enter Cisco IOS commands and parameters through the CLI. Use one of these options to access the CLI:

- [RJ-45 Console Port, page 35](#)
- [USB Mini-Type B Console Port, page 36](#)

Warning: If you connect or disconnect the console cable with power applied to the switch or any device on the network, an electrical arc can occur. This could cause an explosion in hazardous location installations. Be sure that power is removed or the area is nonhazardous before proceeding.

Statement 1080

RJ-45 Console Port

1. Connect the RJ-45-to-DB-9 adapter cable to the 9-pin serial port on the PC (see [Figure 14 on page 36](#)).
2. Connect the other end of the cable to the switch console port.
3. Start the terminal-emulation program on the PC or the terminal.

The program, frequently a PC application such as HyperTerminal or PuTTY, makes communication between the switch and your PC or terminal possible.

Figure 14 Connecting the Console Cable

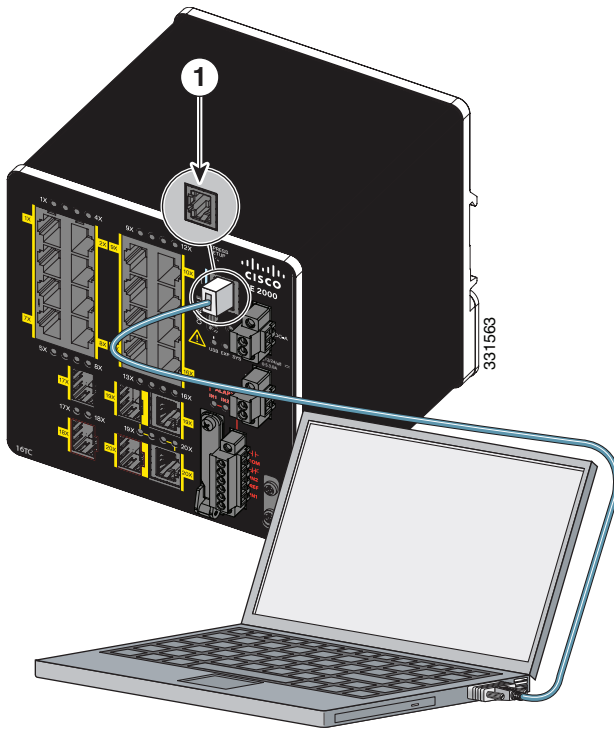

- 1 RJ-45 console port
- 2 Console cable (RJ-45-to-DB-9 adapter cable)

4. Configure the baud rate and character format of the PC or terminal to match the console port characteristics:

- 9600 baud
- 8 data bits
- 1 stop bit
- No parity
- None (flow control)

5. Connect power to the switch as described in [Connecting to Power, page 39](#).

The PC or terminal displays the bootloader sequence.

6. Press **Enter** to display the setup prompt.

7. Follow the steps in [Completing the Setup Program, page 106](#).

USB Mini-Type B Console Port

If you are connecting the switch USB-mini console port to a Windows-based PC for the first time, install a USB driver. See [Installing the Cisco Microsoft Windows XP, 2000, Vista, 7, 8, and 10 USB Device Driver, page 105](#) for more information.

To remove the cover from the USB mini-type B console port:

1. Use a Phillips screwdriver to loosen the captive screw on the USB mini-type B console port cover. See [Figure 15 on page 37](#).

2. Remove the cover.

Figure 15 Removing the USB Mini-Type B Console Port Cover

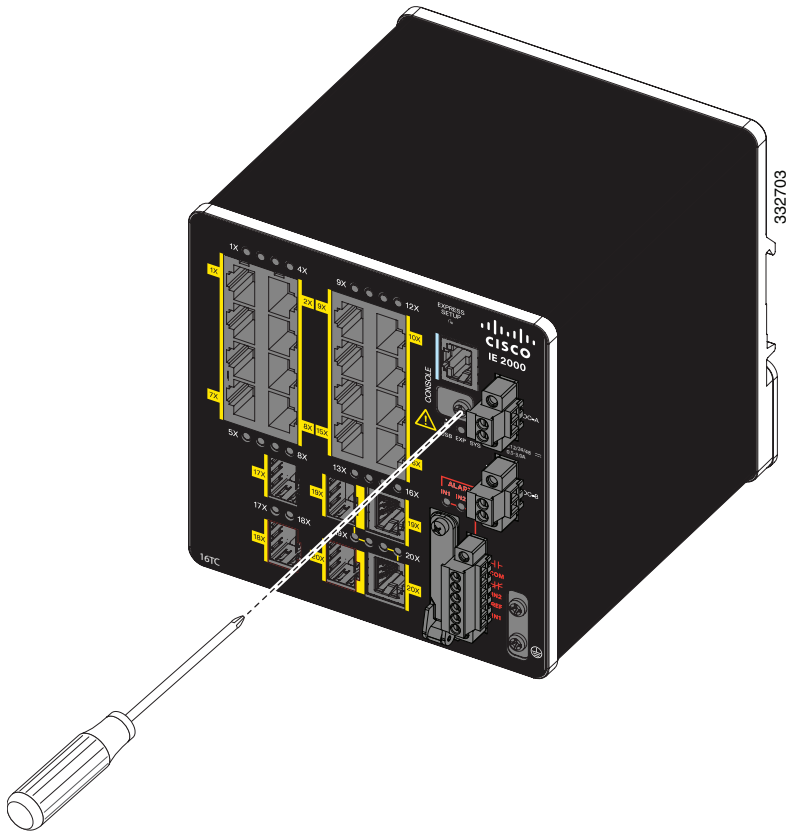

3. Connect a USB cable to the PC USB port.
4. Connect the other end of the cable to the switch mini-B (5-pin connector) USB-mini console port. See [Figure 16 on page 38](#).

Figure 16 Connecting the USB-Mini Console Cable

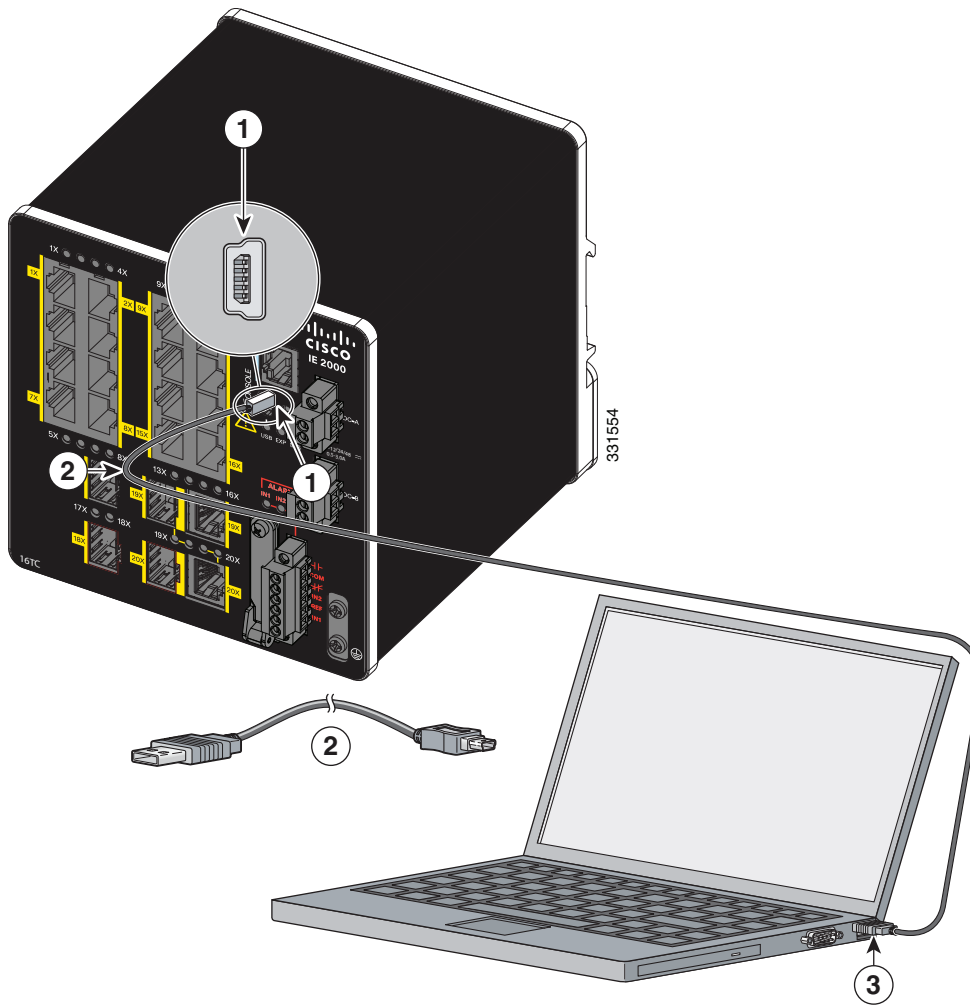

- 1 USB-mini console port 3 USB port on the PC
- 2 USB cable

5. Identify the COM port assigned to the USB-mini console port:

- a. Choose **Start > Control Panel > Systems**.
- b. Click the **Hardware** tab and choose **Device Manager**. Expand the **Ports** section. The assigned COM port appears in parenthesis at the end of the line with this entry: Cisco USB System Management Console.

6. Start the terminal-emulation program on the PC or the terminal.

The program, frequently a PC application such as HyperTerminal or ProcommPlus, makes communication possible between the switch and your PC or terminal.

7. Configure the COM port.

8. Configure the baud rate and character format of the PC or terminal to match the console port characteristics:

- 9600 baud
- 8 data bits

- 1 stop bit
- No parity
- None (flow control)

9. Connect power to the switch as described in [Connecting to Power, page 39](#).

10. When the PC or terminal displays the bootloader sequence, press **Enter** to display the setup prompt.

11. Follow the steps in [Completing the Setup Program, page 106](#).

Connecting to Power

Tools and Equipment

Obtain these necessary tools and equipment:

- Ratcheting torque flathead screwdriver that exerts up to 15 in-lb (1.69 N-m) of pressure.
- For the protective ground connector, obtain a single or pair of stud size 6 ring terminals (such as Hollingsworth part number R3456B or equivalent).
- Crimping tool (such as Thomas & Bett part number WT2000, ERG-2001, or equivalent).
- 10-gauge copper ground wire (such as Belden part number 9912 or equivalent).
- For DC power connections, use UL- and CSA-rated, style 1007 or 1569 twisted-pair copper appliance wiring material (AWM) wire (such as Belden part number 9318).
- Wire-stripping tools for stripping 10- and 18-gauge wires.
- A number-2 Phillips screwdriver.
- A flat-blade screwdriver.

Supported Power Supplies

The supported power supplies are listed in [Table 11 on page 39](#).

Table 11 Supported Power Supplies

	PWR-IE65W-PC-DC	PWR-IE65W-PC-AC	PWR-IE50W-AC-IEC	PWR-IE50W-AC
Current	DC-DC	AC-DC	AC-DC	AC-DC
Input	18-60 VDC/4.3 Amp	110/220 VAC and 88-300 VDC	110/220 VAC	110/220VAC and 88-300 VDC
Output	54VDC/1.2 Amp	54VDC/1.2 Amp	24VDC/2.1Amp	24 VDC / 2.1Amp
Dimensions	5.9 in H x 2.1 in. W x 4.9 in. D	5.9 in. H x 2.1 in. W x 4.9 in. D	5.8 in. H x 2 in. W x 4.4 in. D	5.8 in. H x 2 in. W x 4.4 in. D
Attachable?	Non-attachable	Non-attachable	Attachable unit	Attachable unit
Usage	Designed for PoE ¹ modules, can be used to power the switch.	Designed for PoE modules, can be used to power the switch.	Powers the switch. Cannot be used to power PoE modules, which require 48V DC.	Powers the switch. Cannot be used to power PoE modules, which require 48V DC.

-
1. The models that support PoE provide up to four ports of either PoE (15.4 W per port; IEEE 802.3af) or PoE+ (30 W per port; IEEE 802.3at), depending on the power source used. See [Power Requirements, page 82](#).

Installing the Power Converter on a DIN Rail, Wall, or Rack Adapter

You install the power converter on a DIN rail, wall, or rack as you would a switch module.

Warning: This equipment is supplied as “open type” equipment. It must be mounted within an enclosure that is suitably designed for those specific environmental conditions that will be present and appropriately designed to prevent personal injury resulting from accessibility to live parts. The interior of the enclosure must be accessible only by the use of a tool. The enclosure must meet IP 54 or NEMA type 4 minimum enclosure rating standards. Statement 1063

Caution: To prevent the switch assembly from overheating, there must be a minimum of 3 inches (76.19 mm) between any other device and the top, bottom, or sides of the switch assembly.

Grounding the Switch

Follow the grounding requirements at your site.

Warning: This equipment must be grounded. Never defeat the ground conductor or operate the equipment in the absence of a suitably installed ground conductor. Contact the appropriate electrical inspection authority or an electrician if you are uncertain that suitable grounding is available. Statement 1024

Warning: This equipment is intended to be grounded to comply with emission and immunity requirements. Ensure that the switch functional ground lug is connected to earth ground during normal use. Statement 1064

Caution: To ensure that the equipment is reliably connected to earth ground, follow the grounding procedure instructions, and use a UL-listed ring terminal lug suitable for number 10-to-12 AWG wire, such as Hollingsworth part number R3456B or equivalent)

Caution: Use at least a 4 mm² conductor to connect to the external grounding screw.

The ground lug is not supplied with the switch. You can use one of the these options:

- Single ring terminal
- Two single ring terminals

To ground the switch to earth ground by using the ground screw, follow these steps:

1. Use a standard Phillips screwdriver or a ratcheting torque screwdriver with a Phillips head to remove the ground screw from the front panel of the switch.

Store the ground screw for later use.

2. Use the manufacturer’s guidelines to determine the wire length to be stripped.
3. Insert the ground wire into the ring terminal lug, and using a crimping tool, crimp the terminal to the wire. See [Figure 17 on page 41](#).

If two ring terminals are being used, repeat this action for a second ring terminal.

Figure 17 Crimping the Ring Terminal

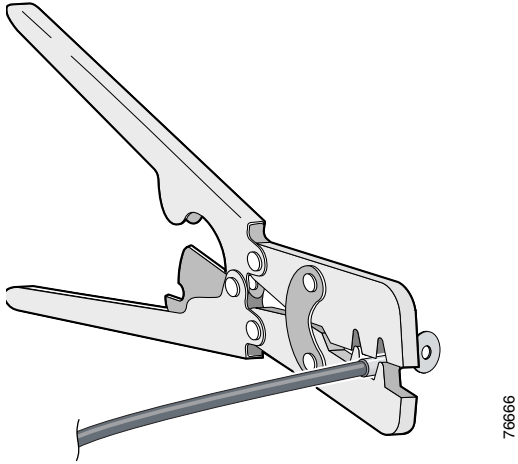

4. Slide the ground screw through the terminal.
5. Insert the ground screw into the functional ground screw opening on the front panel.
6. Use a ratcheting torque screwdriver to tighten the ground screws and ring terminal to the switch front panel to 3.5 in-lb (0.4 N-m). See [Figure 18 on page 42](#) or [Figure 19 on page 43](#).

Note: Do not exceed 3.5 in-lb (0.4 N-m) of torque.

Figure 18 Installing the Ground-Lug Screw (Single Ring Terminal)

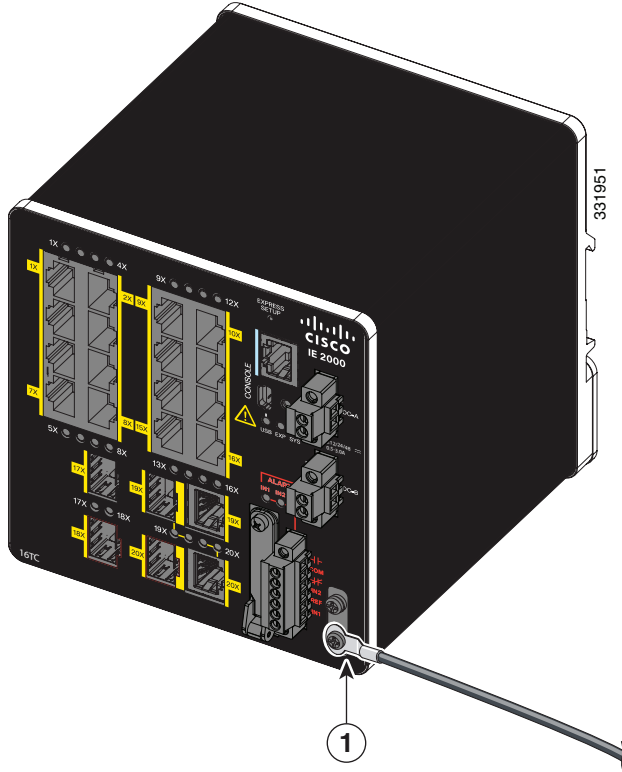

- 1 Ground cable

Figure 19 Installing the Ground-Lug Screws (Two Single Ring Terminals)

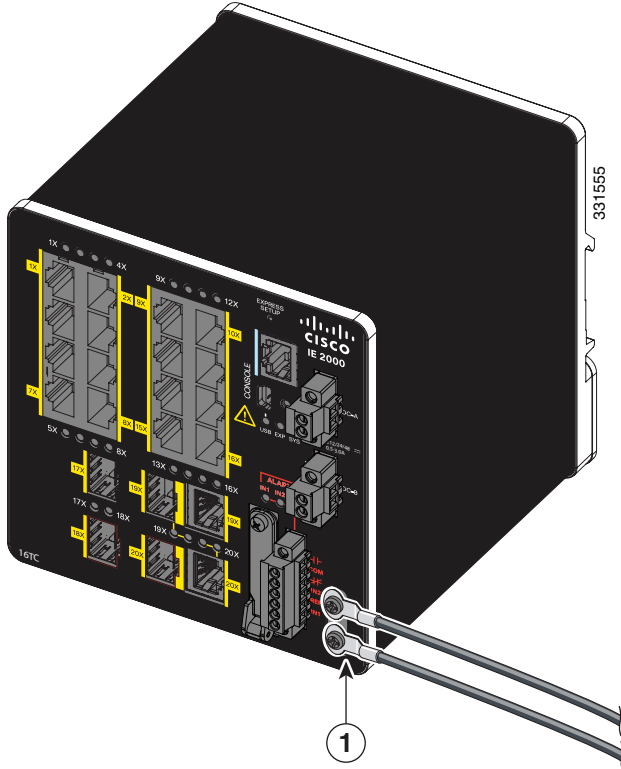

1 Ground cable

7. Attach the other end of the ground wire to a grounded bare metal surface, such as a ground bus, a grounded DIN rail, or a grounded bare rack.

Connecting the Power Converter to an AC Power Source

These sections describe the steps required to connect the power converter to an AC power source:

- [Preparing the AC Power Connection, page 43](#)
- [Connecting the AC Power Source to the Power Converter, page 44](#)

Preparing the AC Power Connection

To connect the power converter to an AC power source, you need an AC power cord. Power cord connector types and standards vary by country. Power-cord wiring color codes also vary by country. You must have a qualified electrician select, prepare, and install the appropriate power cord to the power supply.

Use copper conductors only, rated at a minimum temperature of 167° F (75° C).

This section does not apply to PWR-IE50W-AC-IEC, which has pluggable IEC connector.

Connecting the AC Power Source to the Power Converter

Caution: AC power sources must be dedicated AC branch circuits. Each branch circuit must be protected by a dedicated two-pole circuit breaker.

Caution: Do not turn on AC power until the wiring is secured.

1. Remove the plastic cover from the input power terminals and set it aside.
2. Insert the exposed ground wire lead into the power converter ground wire connection.

Ensure that only wire *with insulation* extends from the connector. See [Figure 20 on page 44](#), item 1. Note that the position of the power converter may vary on different switch models.

Figure 20 Connecting AC Power

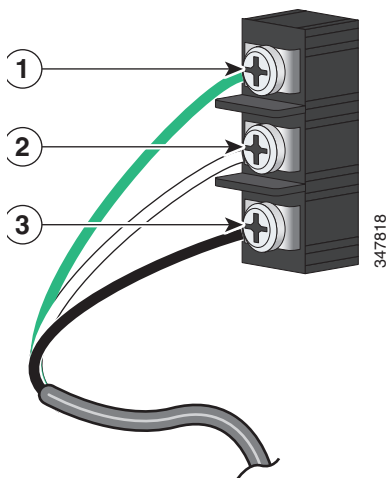

- | | | | |
|---|------------|---|---------|
| 1 | Ground | 3 | AC line |
| 2 | AC neutral | | |

3. Tighten the ground wire terminal block screw.

Note: Torque to 8 in.-lb, not to exceed 10 in.-lb.

4. Insert the line and neutral wire leads into the terminal block line and neutral connections. See [Figure 20 on page 44](#), items 2 and 3.

Ensure that you cannot see any wire lead, and that only wire *with insulation* extends from the connectors.

5. Tighten the line and neutral terminal block screws to 8 in.-lb torque.

Note: Do not exceed 10 in.-lb torque.

6. Replace the plastic cover over the terminal block.
7. Connect the other end of the wiring to your AC power source.

Connecting the Power Converter to a DC Power Source

You can also connect the power converter to a DC power source. Several power supplies can be used. Refer to [Table 11 on page 39](#) for the appropriate DC input ratings.

Use copper conductors only, rated at a minimum temperature of 167°F (75°C).

1. Measure a single length of stranded copper wire long enough to connect the power converter to the earth ground.

The wire color differs depending on country.

For connections from the power converter to earth ground, use shielded 18-AWG stranded copper wire, such as Belden part number 9912 or the equivalent.

2. Measure a length of twisted-pair copper wire long enough to connect the power converter to the DC power source.

For DC connections from the power converter to the DC source, use 18-AWG twisted-pair copper wire, such as Belden part number 9344 or the equivalent.

3. Using a 18-gauge wire-stripping tool, strip the ground wire and both ends of the twisted pair wires to 0.25 inch (6.3 mm) ± 0.02 inch (0.5 mm).

Note: Do not strip more than 0.27 inch (6.8 mm) of insulation from the wires. Stripping more than the recommended amount of wire can leave exposed wire from the power and relay connector after installation.

4. Connect one end of the stranded copper wire to a grounded bare metal surface, such as a ground bus, a grounded DIN rail, or a grounded bare rack.
5. Insert the other end of the exposed ground wire lead into the earth-ground wire connection on the power converter terminal block.

Only wire *with insulation* should extend from the connection. See [Figure 21 on page 46](#), item 1.

The position of the power converter varies on different switch models.

6. Tighten the earth-ground wire connection terminal block screw to 8 in.-lb torque.

Note: Do not exceed 10 in.-lb torque.

Figure 21 AC/DC Power Input Terminal Block Wire Connections to a DC Source

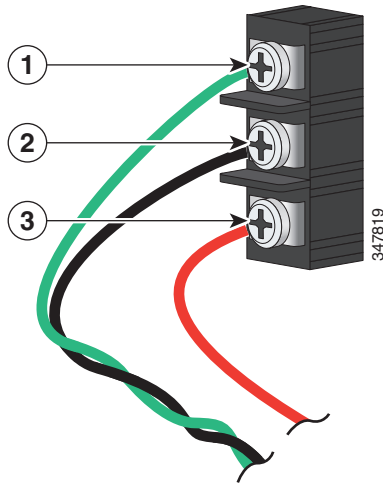

- 1 Earth ground wire connection
- 2 Return wire connection (to DC return)
- 3 Positive DC connection

Warning: An exposed wire lead from a DC-input power source can conduct harmful levels of electricity. Be sure that no exposed portion of the DC-input power source wire extends from the power and relay connector. Statement 122

- 7. Insert the twisted-pair wire leads into the terminal block line and neutral connections.
- 8. Insert the wire (labeled number 1 in [Figure 21 on page 46](#)) lead into the neutral wire connection and the wire (labeled number 2 in [Figure 21 on page 46](#)) lead into the line wire connection.
Ensure that only wire *with insulation* extends from the connectors. See [Figure 21 on page 46](#).
- 9. Tighten the line and neutral terminal block screws to 8 in.-lb torque.
note: Do not exceed 10 in.-lb torque.
- 10. Connect the red wire to the positive pole of the DC power source, and connect the black wire to the return pole.
Ensure that each pole has a current-limiting-type fuse rated to at least 600 VAC/DC (such as the KLKD Midget fuse).

Wiring the DC Power Source

Read these cautions and warnings before wiring the switch the DC power source.

Caution: This product is intended to be supplied by a Listed Class 2 power source marked with Class 2 and rated from 9.6V to 60VDC, 2.1A.

Warning: A readily accessible two-poled disconnect device must be incorporated in the fixed wiring. Statement 1022

Warning: This product relies on the building's installation for short-circuit (overcurrent) protection. Ensure that the protective device is rated not greater than: 3A. Statement 1005

Warning: Installation of the equipment must comply with local and national electrical codes. Statement 1074

Warning: Before performing any of the following procedures, ensure that power is removed from the DC circuit. Statement 1003

Warning: Only trained and qualified personnel should be allowed to install, replace, or service this equipment.
Statement 1030

Caution: For wire connections to the power and alarm connectors, you must use UL- and CSA-rated, style 1007 or 1569 twisted-pair copper appliance wiring material (AWM) wire (such as Belden part number 9318).

To wire the switch to a DC power source, follow these steps:

1. Locate the two power connectors on the switch front panel labeled DC-A and DC-B (see [Figure 22 on page 47](#))

note: On the PoE-capable models of the switch, there is a third DC-input power connector on the switch front panel labeled PoE. See [Connecting Power to the Switch PoE DC-Input \(Optional\)](#), page 53.

Figure 22 Power Connector

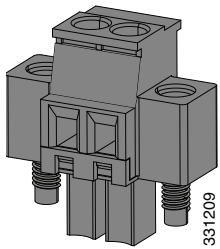

2. Identify the connector positive and return DC power connections.

The labels for power connectors DC-A and DC-B are on the switch panel as displayed in [Table 12 on page 47](#).

Table 12 DC-A and DC-B Power Connector Labels

Label	Connection
+	Positive DC power connection
-	Return DC power connection

3. Measure two strands of twisted-pair copper wire (18-to-20 AWG) long enough to connect to the DC power source.
4. Using an 18-gauge wire-stripping tool, strip each of the two twisted pair wires coming from each DC-input power source to 0.25 inch (6.3 mm) \pm 0.02 inch (0.5 mm).

Note: Do not strip more than 0.27 inch (6.8 mm) of insulation from the wire. Stripping more than the recommended amount of wire can leave exposed wire from the power connector after installation.

Figure 23 Stripping the Power Connection Wire

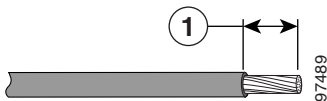

- 1 0.25 in. (6.3 mm) \pm 0.02 in. (0.5 mm)

5. Remove the two captive screws that attach the power connector to the switch, and remove the power connector.

Remove both connectors if you are connecting to two power sources. See [Figure 24 on page 48](#).

Figure 24 Removing the Power Connectors from the Switch

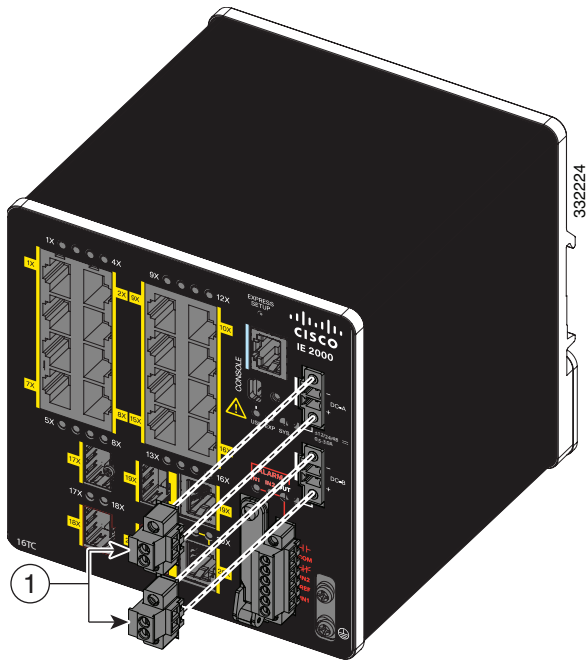

1 Power connectors

6. On the power connector, insert the exposed part of the positive wire into the connection labeled “+” and the exposed part of the return wire into the connection labeled “-”. See [Figure 25 on page 49](#).

Ensure that you cannot see any wire lead. Only wire *with insulation* should extend from the connector.

Warning: An exposed wire lead from a DC-input power source can conduct harmful levels of electricity. Be sure that no exposed portion of the DC-input power source wire extends from the connector(s) or terminal block(s).
Statement 122

Figure 25 Inserting Wires in the Power Connector

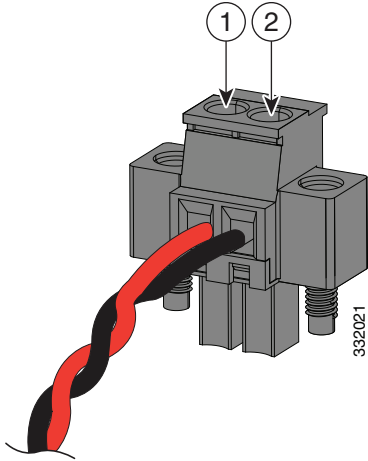

- 1 Power source positive connection 2 Power source return connection

7. Use a ratcheting torque flathead screwdriver to torque the power connector captive screws (above the installed wire leads) to 2 in-lb (0.23 N-m). See [Figure 26 on page 50](#).

Note: Do not over-torque the power connector's captive screws. The torque should not exceed 2 inch-lbs (0.23 N-m).

Figure 26 Torquing the Power Connector Captive Screws

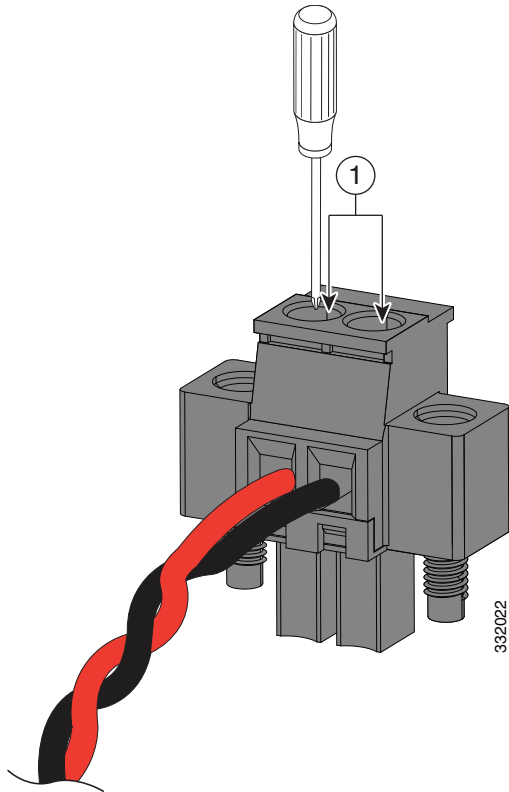

1 Power connector captive screws

8. Connect the other end of the positive wire to the positive terminal on the DC power source, and connect the other end of the return wire to the return terminal on the DC power source.

When you are testing the switch, one power connection is sufficient. If you are installing the switch and are using a second power source, repeat steps 4 through 8 using the second power connector.

[Figure 27 on page 51](#) shows the completed DC-input wiring on a power connector for a primary power source and an optional secondary power source.

Figure 27 Completed DC Power Connections on the Power Connectors

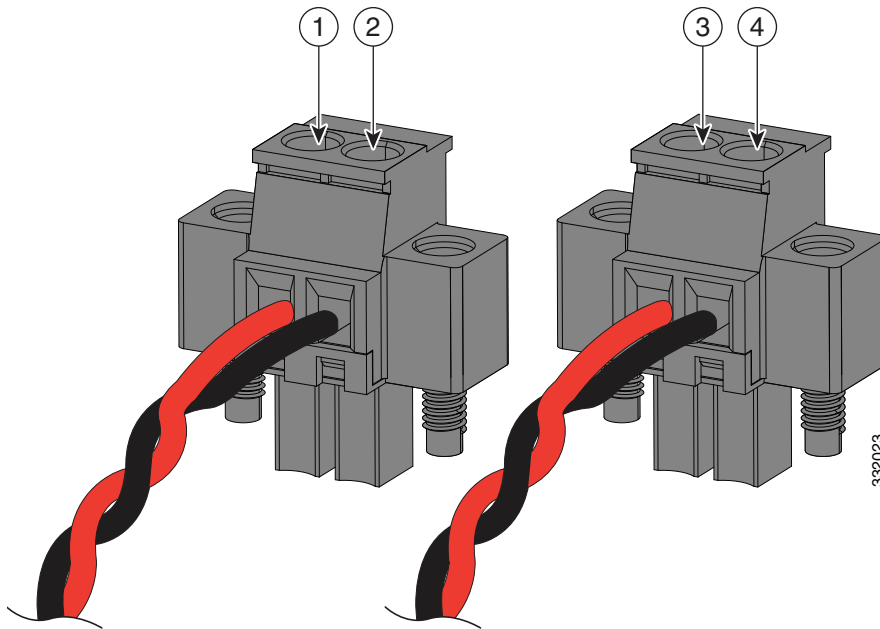

- 1 Power source A positive connection
- 2 Power source A return connection

- 3 Power source B positive connection
- 4 Power source B return connection

For a -48 VDC power source, this table describes the wiring connections for [Figure 27 on page 51](#).

- 1 Power source A return connection
- 2 Power source A -48 VDC connection

- 3 Power source B return connection
- 4 Power source B -48 VDC connection

Attaching the Power Connectors to the Switch

To attach the power connectors to the front panel of the switch, follow these steps:

1. Insert one power connector into the DC-A receptacle on the switch front panel, and the other into the DC-B receptacle. See [Figure 28 on page 52](#).

Warning: Failure to securely tighten the captive screws can result in an electrical arc if the connector is accidentally removed. Statement 397

Warning: When you connect or disconnect the power and/or alarm connector with power applied, an electrical arc can occur. This could cause an explosion in hazardous area installations. Be sure that all power is removed from the switch and any other circuits. Be sure that power cannot be accidentally turned on or verify that the area is nonhazardous before proceeding. Statement 1058

Figure 28 Attaching the Power Connectors to the Switch

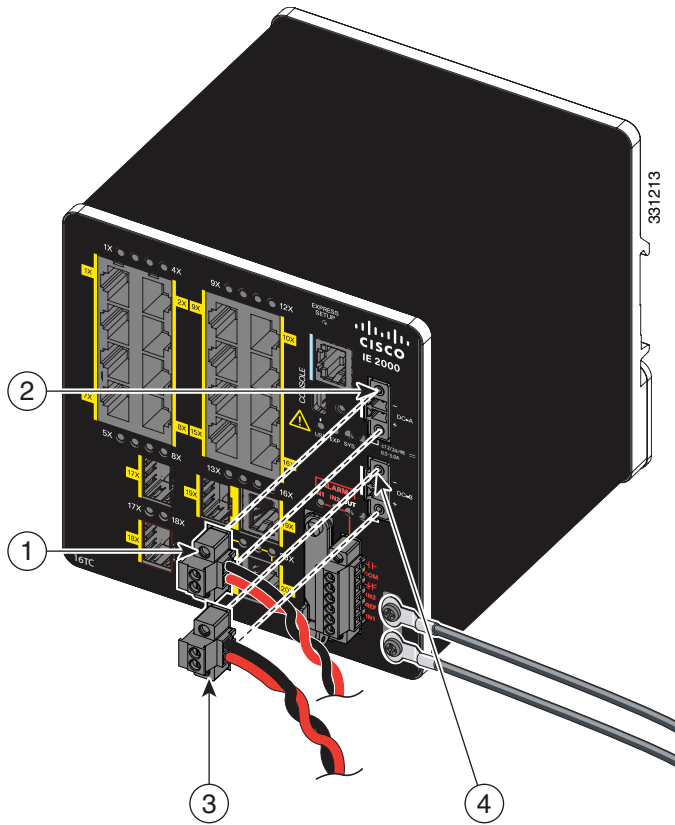

- 1 DC-A power connector
- 2 DC-A power connection

- 3 DC-B power connector
- 4 DC-B power connection

Figure 29 Connecting the Power Connectors to the Switch

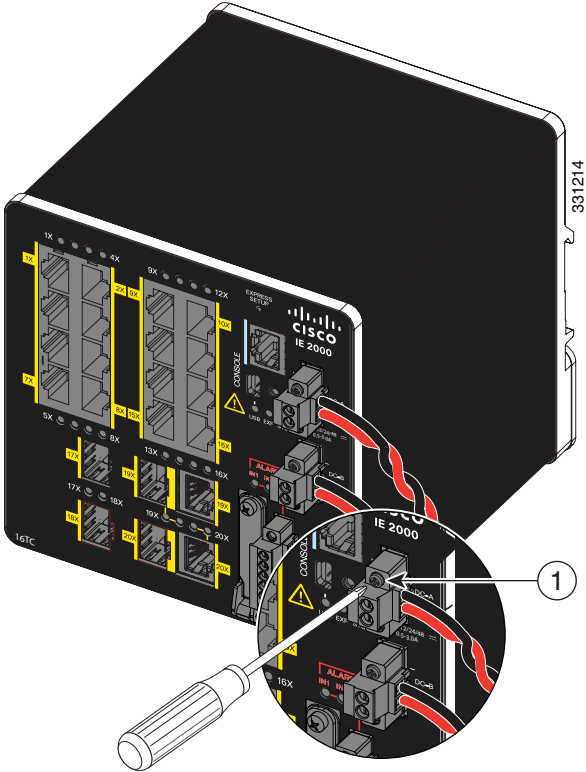

1 DC-A power connector upper captive screw

2. Use a ratcheting torque flathead screwdriver to tighten the captive screws on the sides of the power connectors.

When you are testing the switch, one power source is sufficient. If you are installing the switch and are using a second power source, repeat this procedure for the second power connector (DC-B), which installs just below the primary power connector (DC-A).

When you are installing the switch, secure the wires coming from the power connector so that they cannot be disturbed by casual contact. For example, use tie wraps to secure the wires to the rack.

Connecting Power to the Switch PoE DC-Input (Optional)

This procedure is applicable only to the IE 2000/2000U switch models that are PoE capable. If you have a PoE capable IE 2000 switch and do not plan on using PoE, you do not need to attach power to the PoE DC-input connector; the switch can operate without the connection being made.

Figure 30 shows how a second power supply is connected to the switch to support PoE. PoE-capable Switch with PoE Power Supply Module Connected.

1. Verify that power is off to the DC circuit that you are going to attach to the switch PoE DC-input connector.
This can be either of the two power supplies (AC-input or DC-input) or site source DC.

As an added precaution, place the appropriate safety flag and lockout devices at the source power circuit breaker, or place a piece of adhesive tape over the circuit breaker handle to prevent accidental power restoration while you are working on the circuit.

2. Locate the PoE DC-input power connector, which is labeled PoE, on the switch front panel.
3. Loosen the power connector's two screws and remove the plug portion of the connector from the switch.
4. Measure two strands of twisted-pair copper wire (18 AWG (0.8 mm²) long enough to connect the switch to the DC power source.
5. Using a wire-stripping tool, strip each of the two twisted pair wires coming from each DC-input power source to 0.25 inch (6.3 mm) ± 0.02 inch (0.5 mm).

Note: Do not strip more than 0.27 inch (6.8 mm) of insulation from the wire. Stripping more than the recommended amount of wire can leave exposed wire from the power connector after installation.

6. Loosen the two captive screws on the PoE power plug and insert the exposed part of the positive wire into the connection labeled "+" and the exposed part of the return wire into the connection labeled "-".

Ensure that you cannot see any wire lead. Only wire *with insulation* should extend from the connector.

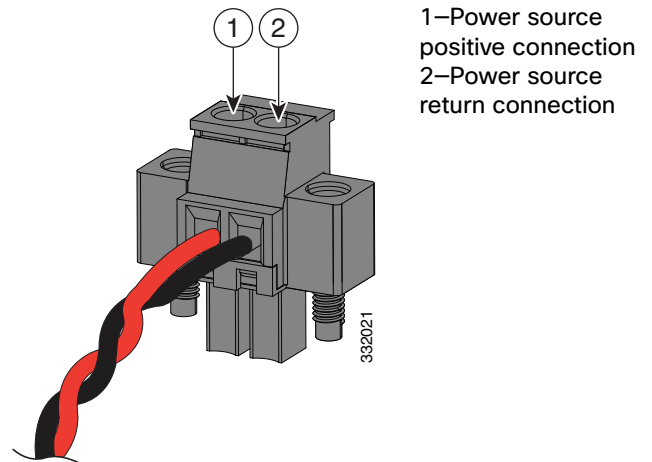

7. Use a ratcheting torque flathead screwdriver to tighten the power connector captive screws (above the installed wire leads) to 2 in-lb (0.23 N-m).

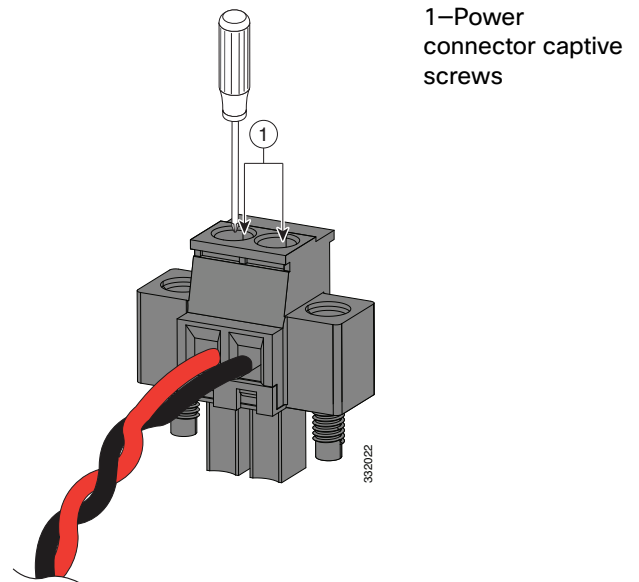

-
8. Connect the other end of the positive wire to the positive terminal on the DC power source, and connect the other end of the return wire to the return terminal on the DC power source.
 9. Insert the wired power plug into the switch PoE power connector and tighten the two screws to secure the plug.

Applying Power to the Power Converter

Move the circuit breaker for the AC outlet or the DC control circuit to the *on* position.

The LED on the power converter front panel is green when the unit is operating normally. The LED is off when the unit is not powered or is not operating normally. After the power is connected, the switch automatically begins the power-on self- test (POST), a series of tests that verifies that the switch functions properly.

Running Boot Fast

When the switch powers on, it automatically initiates a boot fast sequence. The boot fast sequence allows the switch to boot up in less than 60 seconds. To test the switch, follow the steps in these sections:

- [Powering On the Switch, page 56](#)
- [Verifying Boot Fast, page 56](#)
- [Disconnecting Power, page 56](#)

Powering On the Switch

To apply power to a switch that is directly connected to a DC power source, locate the circuit breaker on the panel board that services the DC circuit, and switch the circuit breaker to the ON position.

Verifying Boot Fast

When you power on the switch, it automatically begins a boot fast sequence. The System LED blinks green as the Cisco IOS software image loads. If the boot fast sequence fails, the System LED turns red.

Note: Boot fast failures are usually fatal. Call Cisco TAC immediately if your switch does not complete boot fast successfully. See [Obtaining Documentation and Submitting a Service Request](#).

Note: You can disable the boot fast and run POST by using the Cisco IOS CLI. See the *Cisco IE 2000 Switch Software Configuration Guide* and the *Cisco IE 2000 Switch Command Reference* for more information.

Disconnecting Power

To disconnect power after successfully running boot fast, follow these steps:

1. Turn off power to the switch.
2. Disconnect the cables.

Installing the Switch

This section describes how to install the switch:

- [Installing the Switch on a DIN Rail, page 57](#)
- [Removing the Switch from a DIN Rail, page 58](#)

Warning: This equipment is supplied as “open type” equipment. It must be mounted within an enclosure that is suitably designed for those specific environmental conditions that will be present and appropriately designed to prevent personal injury resulting from accessibility to live parts. The interior of the enclosure must be accessible only by the use of a tool. The enclosure must meet IP 54 or NEMA type 4 minimum enclosure rating standards.
Statement 1063

Warning: When used in a Class I, Division 2, hazardous location, this equipment must be mounted in a suitable enclosure with proper wiring method, for all power, input and output wiring, that complies with the governing electrical codes and in accordance with the authority having jurisdiction over Class I, Division 2 installations.
Statement 1066

Caution: To prevent the switch from overheating, ensure these minimum clearances:

- Top and bottom: 2.0 in. (50.8 mm)
- Exposed side (not connected to the module): 2.0 in. (50.8 mm)
- Front: 2.0 in. (50.8 mm)

Installing the Switch on a DIN Rail

The switch ships with a spring-loaded latch on the rear panel for a mounting on a DIN rail.

You can install the switch as a standalone device on the DIN rail or with the expansion modules already connected. You must connect expansion modules to the switch before installing the switch on the DIN rail.

To attach the switch to a DIN rail, follow these steps:

1. Position the rear panel of the switch directly in front of the DIN rail, making sure that the DIN rail fits in the space between the two hooks near the top of the switch and the spring-loaded latch near the bottom.
2. Holding the bottom of the switch away from the DIN rail, place the two hooks on the back of the switch over the top of the DIN rail. See [Figure 31 on page 58](#).

Caution: Do not stack any equipment on the switch.

Figure 31 Position the Hooks Over the DIN Rail

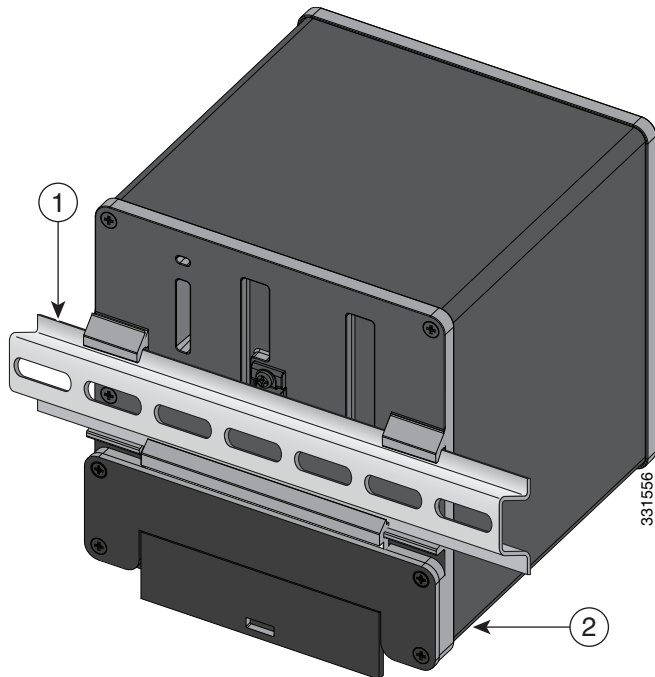

- 1 DIN Rail 2 Switch

3. Push the switch toward the DIN rail to cause the spring-loaded latch at the bottom rear of the switch to move down, and snap into place.

After the switch is mounted on the DIN rail, connect the power and alarm wires, as described in [Connecting Alarm Circuits, page 59](#).

For configuration instructions about the CLI setup program, see [Configuring the Switch with the CLI-Based Setup Program, page 101](#)

For instructions on how to remove the switch from a DIN rail, see [Removing the Switch from a DIN Rail, page 58](#).

Removing the Switch from a DIN Rail

To remove the switch from a DIN rail, follow these steps:

1. Ensure that power is removed from the switch, and disconnect all cables and connectors from the front panel of the switch.
2. Insert a tool such as a flathead screwdriver in the slot at the bottom of the spring-loaded latch and use it to release the latch from the DIN rail. See [Figure 32 on page 59](#).
3. Pull the bottom of the switch away from the DIN rail, and lift the hooks off the top of the DIN rail. See [Figure 32](#).

Figure 32 Releasing the Spring-Loaded Latch from the DIN Rail

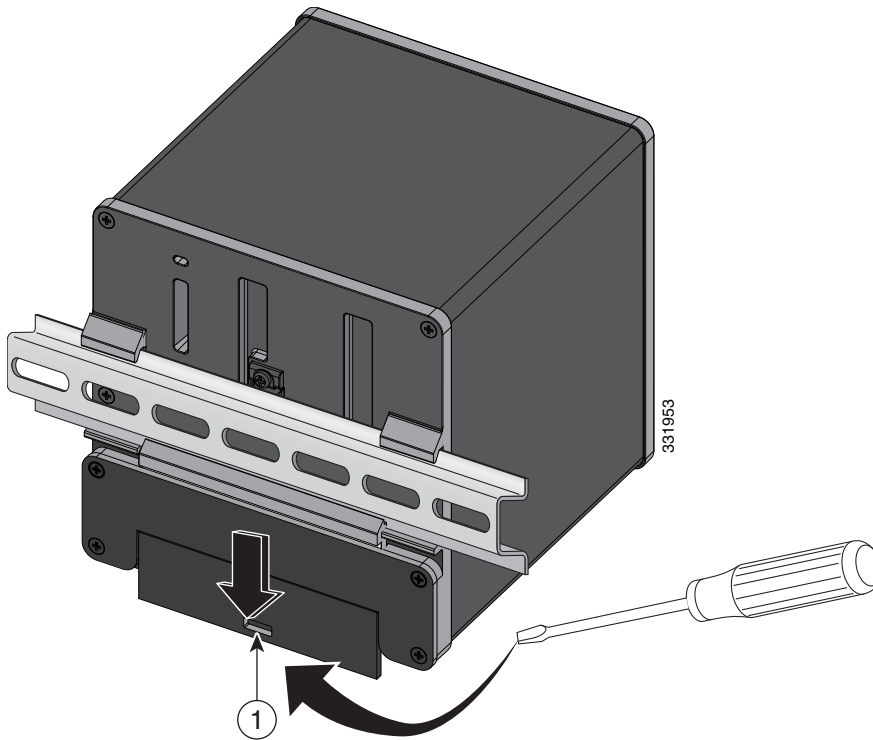

1 Push latch down

4. Remove the switch from the DIN rail.

Connecting Alarm Circuits

After the switch is installed, you are ready to connect the DC power and alarm connections.

- [Wiring the Protective Ground and DC Power for Alarm Circuits, page 59](#)
- [Wiring the External Alarms, page 59](#)

Wiring the Protective Ground and DC Power for Alarm Circuits

For instructions on grounding the switch and connecting the DC power, see [Grounding the Switch, page 40](#).

Wiring the External Alarms

The switch has two alarm input and one alarm output relay circuits for external alarms. The alarm input circuits are designed to sense if the alarm input is open or closed relative to the alarm input reference pin. Each alarm input can be configured as an open or closed contact. The alarm output relay circuit has a normally open and a normally closed contact.

Alarm signals are connected to the switch through the six-pin alarm connector. Three connections are dedicated to the two alarm input circuits: alarm input 1, alarm input 2, and a reference ground. An alarm input and the reference ground wiring connection are required to complete a single alarm input circuit. The three remaining connections are for the alarm output circuit: a normally open output, a normally closed output, and a common signal. An alarm output and the common wiring connection are required to complete a single alarm output circuit.

The labels for the alarm connector are on the switch panel and are displayed in [Table 13 on page 60](#).

Table 13 Alarm Connector Labels (Top to Bottom)

Label	Connection
NO	Alarm Output Normally Open (NO) connection
COM	Alarm Output Common connection
NC	Alarm Output Normally Closed (NC) connection
IN2	Alarm Input 2
REF	Alarm Input Reference Ground connection
IN1	Alarm Input 1

Warning: Explosion Hazard—Do not connect or disconnect wiring while the field-side power is on; an electrical arc can occur. This could cause an explosion in hazardous location installations. Be sure that power is removed or that the area is nonhazardous before proceeding. Statement 1081

Caution: The input voltage source of the alarm output relay circuit must be an isolated source and limited to less than or equal to 24 VDC, 1.0 A or 48 VDC, 0.5 A.

Note: Wire connections to the power and alarm connectors must be UL- and CSA-rated, style 1007 or 1569 twisted-pair copper appliance wiring material (AWM) wire (such as Belden part number 9318).

To wire the switch to an external alarm device, follow these steps:

1. Remove the captive screws that hold the alarm connector on the switch, and remove the connector from the switch chassis.

Figure 33 Removing the Alarm Connector

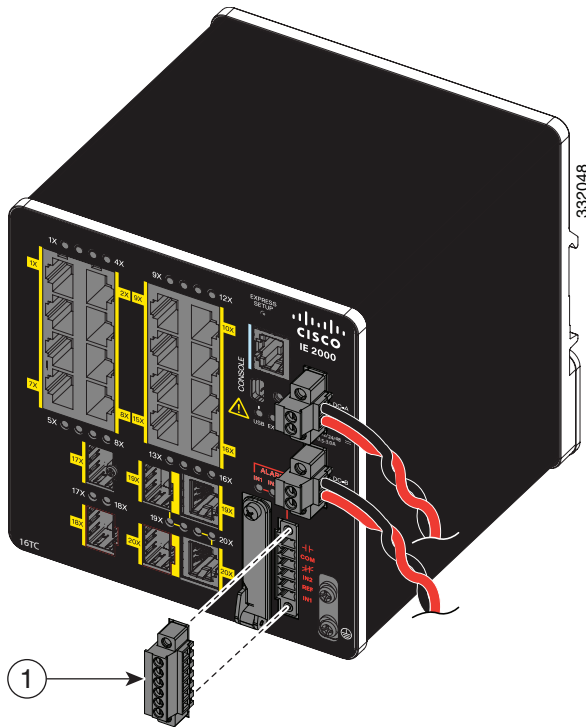

1 Alarm connector

2. Measure two strands of twisted-pair wire (18-to-20 AWG) long enough to connect to the external alarm device.
You can choose between setting up an external alarm input or output circuit.
3. Use a wire stripper to remove the casing from both ends of each wire to 0.25 inch (6.3 mm) \pm 0.02 inch (0.5 mm).
Do not strip more than 0.27 inch (6.8 mm) of insulation from the wires. Stripping more than the recommended amount of wire can leave exposed wire from the alarm connector after installation.
4. Insert the exposed wires for the external alarm device into the connections based on an alarm input or output circuit setup (see [Table 13 on page 60](#)).

For example, to wire an alarm input circuit, complete the IN1 and REF connections (See [Figure 34 on page 62](#)).

Figure 34 Inserting Wires into the Alarm Connector (Alarm Input Circuit)

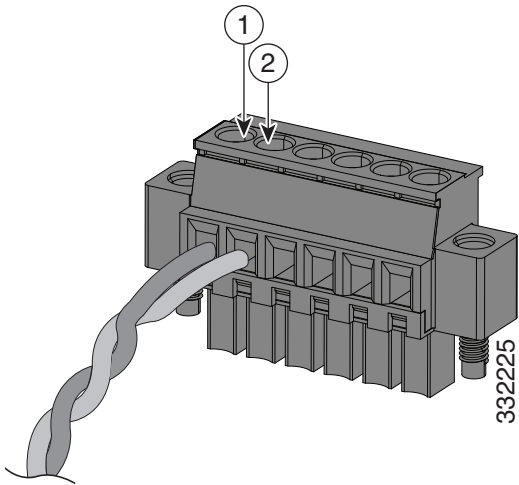

1 IN1 - External device connection 1

2 REF - External device connection 2

5. Use a ratcheting torque flathead screwdriver to tighten the alarm connector captive screw (above the installed wire leads) to 2 in-lb (0.23 N-m). (See [Figure 35 on page 62.](#))

Note: Do not over-torque the power and alarm connectors' captive screws. Do not exceed 2 inch-lbs (0.23 N-m) torque.

Figure 35 Securing the Alarm Connector Captive Screws

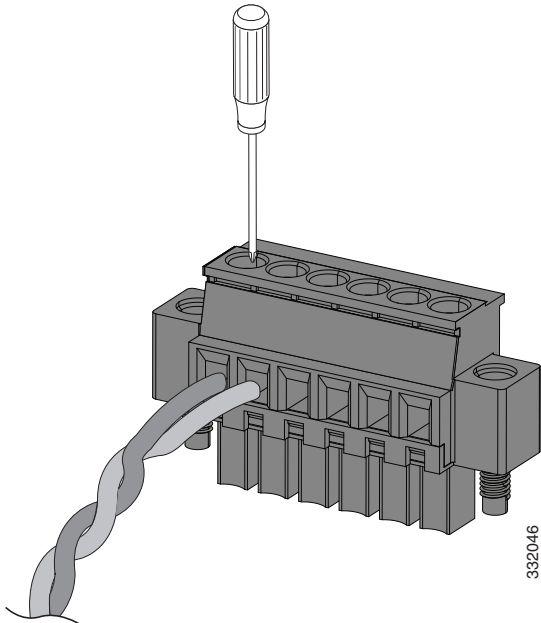

6. Repeat the above steps to insert the input and output wires of one additional external alarm device into the alarm connector.

[Figure 36 on page 63](#) shows the completed wiring for two external alarm devices. The first alarm device circuit is wired as an alarm input circuit; the IN1 and REF connections complete the circuit. The second alarm device circuit is wired as an alarm output circuit that works on a normally open contact basis; the NO and COM connections complete the circuit.

Figure 36 Completed Connections for Three External Alarm Devices on the Alarm Connector

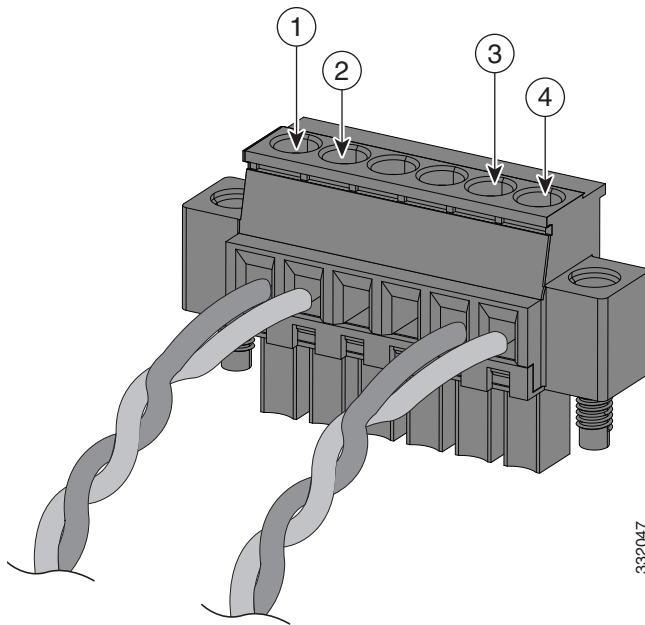

- 1 IN1 wired connection
- 2 REF wired connection

- 3 COM wired connection
- 4 NO wired connection

Attaching the Alarm Connector to the Switch

Warning: Failure to securely tighten the captive screws can result in an electrical arc if the connector is accidentally removed. Statement 397

Warning: When you connect or disconnect the power and/or alarm connector with power applied, an electrical arc can occur. This could cause an explosion in hazardous area installations. Be sure that all power is removed from the switch and any other circuits. Be sure that power cannot be accidentally turned on or verify that the area is nonhazardous before proceeding. Statement 1058

To attach the alarm connector to the front panel of the switch:

1. Insert the alarm connector into the receptacle on the switch front panel. See [Figure 37 on page 64](#).

Figure 37 Connecting the Alarm Connector to the Switch

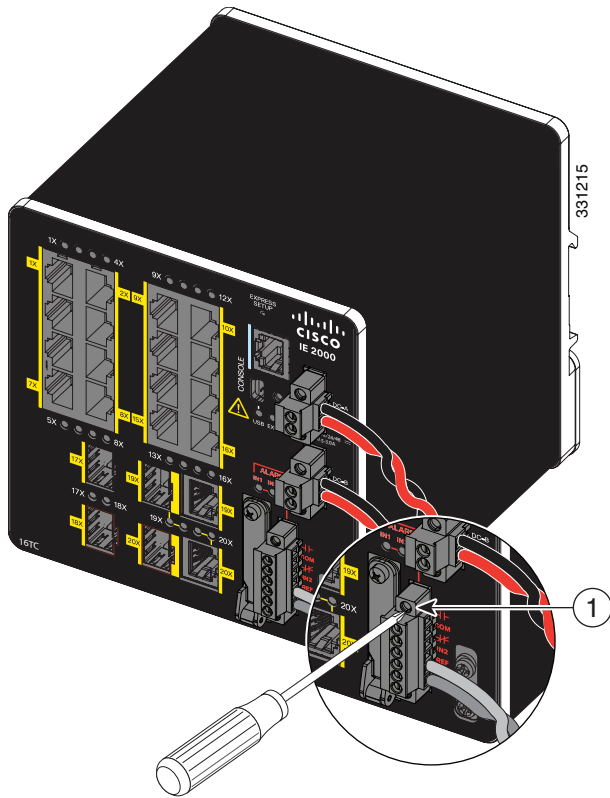

- 1 Alarm connector upper captive screw
2. Use a ratcheting torque flathead screwdriver to tighten the captive screws on the sides of the alarm connector.

Connecting Destination Ports

These section provide more information about connecting to the destination ports:

- [Connecting to 10/100 and 10/100/1000 Ports, page 64](#)
- [Installing and Removing SFP Modules, page 66](#)
- [Connecting to SFP Modules, page 70](#)
- [Connecting to a Dual-Purpose Port, page 72](#)

Connecting to 10/100 and 10/100/1000 Ports

The switch 10/100/1000 ports automatically configure themselves to operate at the speed of attached devices. If the attached ports do not support autonegotiation, you can explicitly set the speed and duplex parameters. Connecting devices that do not autonegotiate or that have their speed and duplex parameters manually set can reduce performance or result in no linkage.

Warning: Do not connect or disconnect cables to the ports while power is applied to the switch or any device on the network because an electrical arc can occur. This could cause an explosion in hazardous location installations. Be sure that power is removed from the switch and cannot be accidentally be turned on, or verify that the area is nonhazardous before proceeding. Statement 1070

To maximize performance, choose one of these methods for configuring the Ethernet ports:

- Let the ports autonegotiate both speed and duplex.
- Set the port speed and duplex parameters on both ends of the connection.

The models that support PoE provide up to four ports of either PoE (15.4 W per port; IEEE 802.3af) or PoE+ (30 W per port; IEEE 802.3at), depending on the power source used. For more information, see [Technical Specifications, page 81](#).

Caution: To prevent electrostatic-discharge (ESD) damage, follow standard board and component handling procedures.

To connect to 10BASE-T, 100BASE-TX or 1000BASE-T devices, follow these steps:

1. When connecting to workstations, servers, routers, and Cisco IP phones, connect a straight-through cable to an RJ-45 connector on the front panel. See [Figure 38 on page 65](#).

When connecting to 1000BASE-T-compatible devices, use a twisted four-pair, CAT5 or higher cable.

The auto-MDIX feature is enabled by default. For configuration information for this feature, see the *Cisco IE 2000 Switch Software Configuration Guide* or the *Cisco IE 2000 Switch Command Reference*.

Figure 38 Connecting to an Ethernet Port

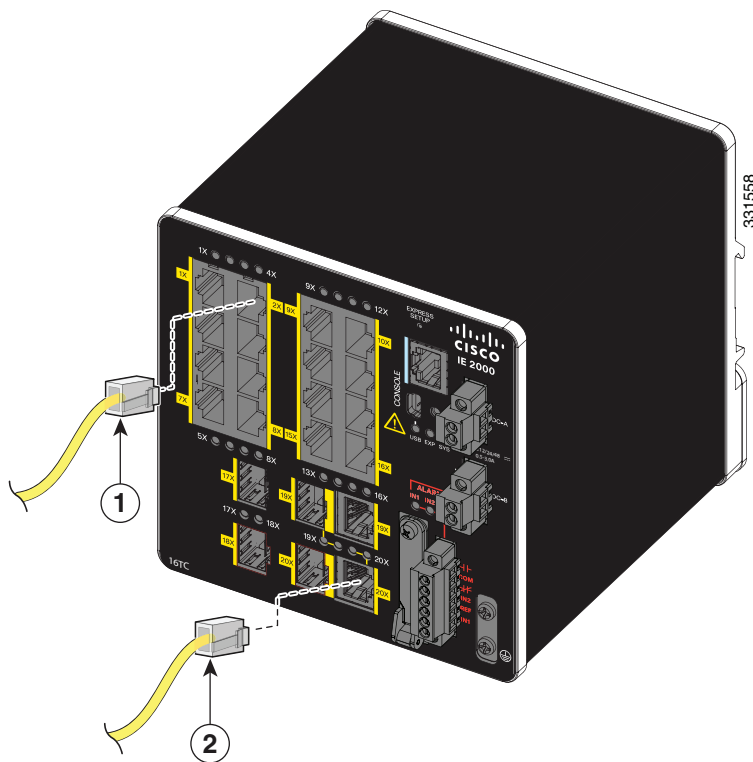

1 10/100 port

2 10/100 or 10/100/100 port (depending on model)

2. Connect the other end of the cable to an RJ-45 connector on the other device.

The port LED turns on when both the switch and the connected device establish the link.

The port LED is amber while Spanning Tree Protocol (STP) discovers the topology and searches for loops. This can take up to 30 seconds, and then the port LED turns green. If the port LED does not turn on:

-
- The device at the other end might not be turned on.
 - There might be a cable problem or a problem with the adapter installed in the attached device. For solutions to cabling problems, see [Troubleshooting, page 75](#)

3. Reconfigure and reboot the connected device if necessary.

4. Repeat Steps 1 through 3 to connect each device.

Installing and Removing SFP Modules

These sections describe how to install and remove SFP modules. SFP modules are inserted into SFP module slots on the front of the switch. Field-replaceable SFP modules provide the uplink interfaces, send (TX) and receive (RX).

You can use any combination of rugged SFP modules. See [Table 2 on page 19](#) for a list of supported modules. Each SFP module must be of the same type as the SFP module on the other end of the cable, and the cable must not exceed the stipulated cable length for reliable communications. See [Table 2 on page 19](#) for cable stipulations for SFP module connections.

Caution: When you use commercial SFP modules such as CWDM and 1000BX-U/D, reduce the maximum operating temperature by 59° F (15° C). The minimum operating temperature is 32° F (0° C).

Caution: To prevent electrostatic-discharge (ESD) damage, follow standard board and component handling procedures.

Warning: Do not insert and remove SFP modules while power is on; an electrical arc can occur. This could cause an explosion in hazardous location installations. Be sure that power is removed or the area is nonhazardous before proceeding. Statement 1087

[Figure 39 on page 67](#) shows an LC SFP module with a bale-clasp latch.

Caution: Do not install or remove the LC SFP module with fiber-optic cables attached because of potential damage to the cables, the cable connector, or the optical interfaces in the SFP module. Disconnect all cables before removing or installing an SFP module. Removing and installing an SFP module can shorten its useful life. Do not remove and insert SFP modules more often than is absolutely necessary.

Figure 39 LC SFP Module with Open Bale-Clasp Latch

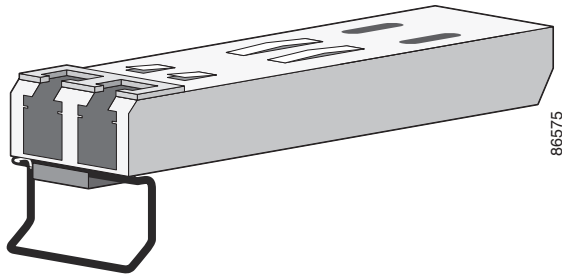
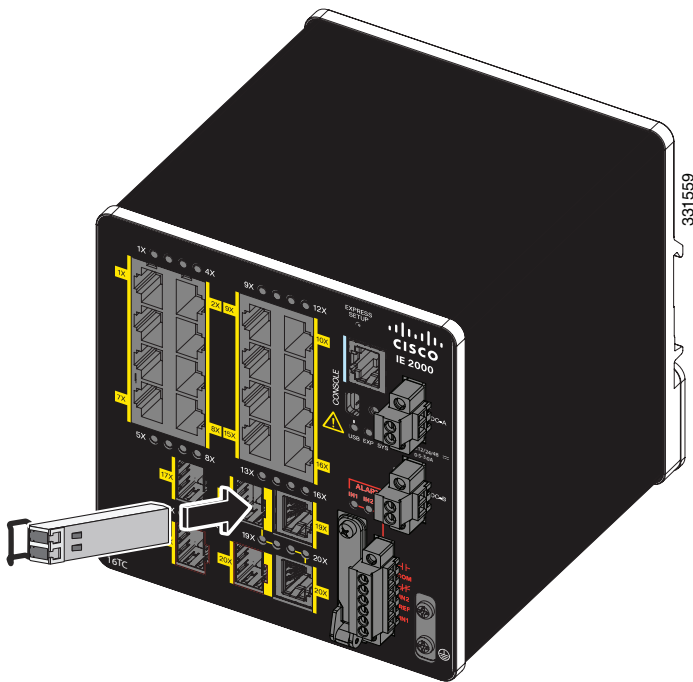

Figure 40 Installing an SFP Module into an SFP Module Slot



Installing LC SFP Modules

To insert an LC SFP module into the SFP module slot:

1. Attach an ESD-preventive wrist strap to your wrist and to a grounded bare metal surface.
2. Find the send (TX) and receive (RX) markings that identify the correct side of the SFP module.

On some SFP modules, the send and receive (TX and RX) markings might be replaced by arrows that show the direction of the connection, either send or receive (TX or RX).

3. Align the SFP module sideways in front of the slot opening.
4. Insert the SFP module into the slot until the connector on the module snaps into place in the rear of the slot. See [Figure 40 on page 67](#).
5. Remove the dust plugs from the SFP module optical ports and store them for later use.

Caution: Do not remove the dust plugs from the SFP module port or the rubber caps from the fiber-optic cable until you are ready to connect the cable. The plugs and caps protect the SFP module ports and cables from contamination and ambient light.

6. Insert the LC cable connector into the SFP module.

Installing 1000BASE-T SFP Modules

The 1000BASE-T (copper) SFP transceiver, see [Figure 41 on page 68](#), has a bale-clasp locking mechanism that secures the transceiver in the module socket. An RJ-45 connector provides the transceiver's interface point to the network.

Figure 41 1000BASE-T SFP Transceiver

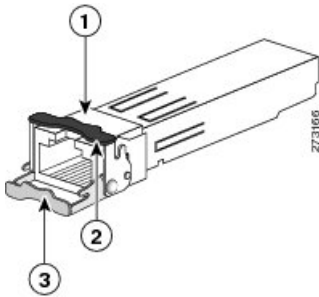

- | | |
|--|--|
| <ol style="list-style-type: none">1 RJ-45 connector2 Closed bale-clasp latch mechanism (locked) | <ol style="list-style-type: none">3 Open bale-clasp latch (unlocked) |
|--|--|

Caution: To comply with GR-1089 intrabuilding lightning immunity requirements, you must use grounded, shielded, twisted-pair, CAT5 cabling.

When connecting to a 1000BASE-T-compatible server, workstation, or router, use four twisted-pair, straight-through CAT5 cabling for the SFP transceiver port. When connecting to a 1000BASE-T-compatible switch or repeater, use four twisted-pair, crossover CAT5 cabling.

To install a 1000BASE-T SFP transceiver:

1. Attach an ESD-preventive wrist strap to your wrist and to the ESD ground connector on the chassis or to a properly grounded bare metal surface.

Caution: To avoid ESD damage, handle the SFP by its sides; do not touch the connector pins.

2. Remove the new 1000BASE-T SFP module from its protective packaging.
3. Check the markings on the SFP transceiver to verify that you have the correct model for your network.
4. Position the SFP transceiver in front of the port socket opening.

Note: Different Cisco devices have different SFP transceiver socket configurations. Your Cisco device might require that the SFP transceiver be installed with the bale-clasp either in a latch-up or a latch-down orientation. Verify that the SFP transceiver is oriented correctly when you position it in front of the port socket.

5. With the bale-clasp closed (locked), slide the SFP transceiver into the socket until you feel it snap in place in the socket. You may hear an audible click as the SFP transceiver latch engages in the socket ([Figure 40 on page 67](#)).
6. Connect the network interface cable RJ-45 plug to the SFP RJ-45 connector.
7. Observe the port status LED:
 - Green indicates that the SFP transceiver and the target device established a link.

- Amber indicates that the port is discovering the network topology and searching for loops. This process takes about 30 seconds, and then the LED turns green.
- Off indicates that the target device might not be turned on, there might be a cable problem, or there might be a problem with the adapter installed in the target device. Refer to [Troubleshooting, page 75](#) for solutions to cabling problems.

Removing SFP Modules from SFP Module Slots

To remove an SFP module from a module receptacle:

1. Attach an ESD-preventive wrist strap to your wrist and to a grounded bare metal surface.
2. Disconnect the LC from the SFP module.
3. Insert a dust plug into the optical ports of the SFP module to keep the optical interfaces clean.
4. Unlock and remove the SFP module.

If the module has a bale-clasp latch, pull the bale out and down to eject the module. If the bale-clasp latch is obstructed and you cannot use your index finger to open it, use a small, flat-blade screwdriver or other long, narrow instrument to open the bale-clasp latch. See [Figure 42 on page 69](#).

Figure 42 Opening a Bale-Clasp Latch on an SFP Module Using a Flat-Blade Screwdriver

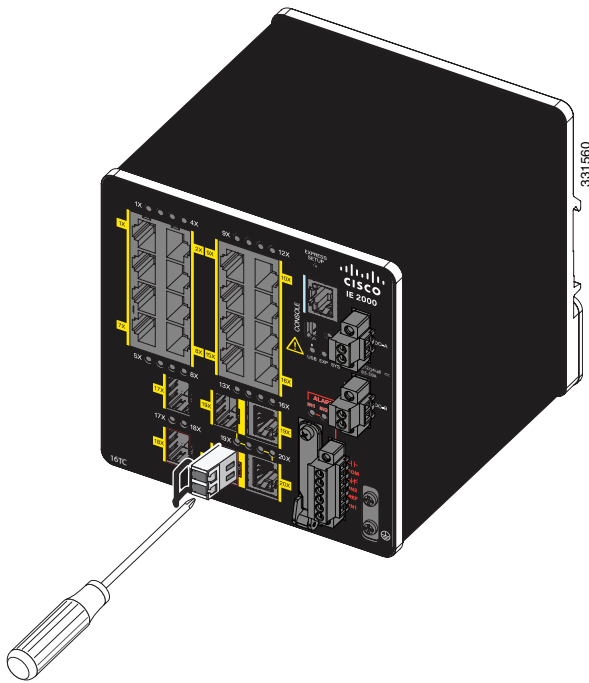

1 Bale clasp

5. Grasp the SFP module between your thumb and index finger, and carefully remove it from the module slot.
6. Place the removed SFP module in an antistatic bag or other protective environment.

Connecting to SFP Modules

This section describes how to connect to a fiber-optic or copper SFP port. To connect to an RJ-45 Gigabit Ethernet port, see [Connecting to a Dual-Purpose Port, page 72](#). For instructions on how to install or remove an SFP module, see [Installing and Removing SFP Modules, page 66](#).

Warning: Class 1 laser product. Statement 1008

Warning: Do not connect or disconnect cables to the ports while power is applied to the switch or any device on the network because an electrical arc can occur. This could cause an explosion in hazardous location installations. Be sure that power is removed from the switch and cannot be accidentally be turned on, or verify that the area is nonhazardous before proceeding. Statement 1070

Caution: Do not remove the rubber plugs from the SFP module port or the rubber caps from the fiber-optic cable until you are ready to connect the cable. The plugs and caps protect the SFP module ports and cables from contamination and ambient light.

Caution: Before connecting to the SFP module, be sure that you understand the port and cabling guidelines in [Preparing for Installation, page 29](#). See [Cable and Connectors, page 87](#) for information about the LC on the SFP module.

Caution: To prevent ESD damage, follow standard board and component handling procedures.

Connecting to a Fiber Optic SFP Module

To connect a fiber-optic cable to an SFP module, follow these steps:

1. Remove the rubber plugs from the module port and fiber-optic cable, and store them for future use.
2. Insert one end of the fiber-optic cable into the SFP module port. See [Figure 43 on page 71](#).

Figure 43 Connecting to a Fiber-Optic SFP Module Port

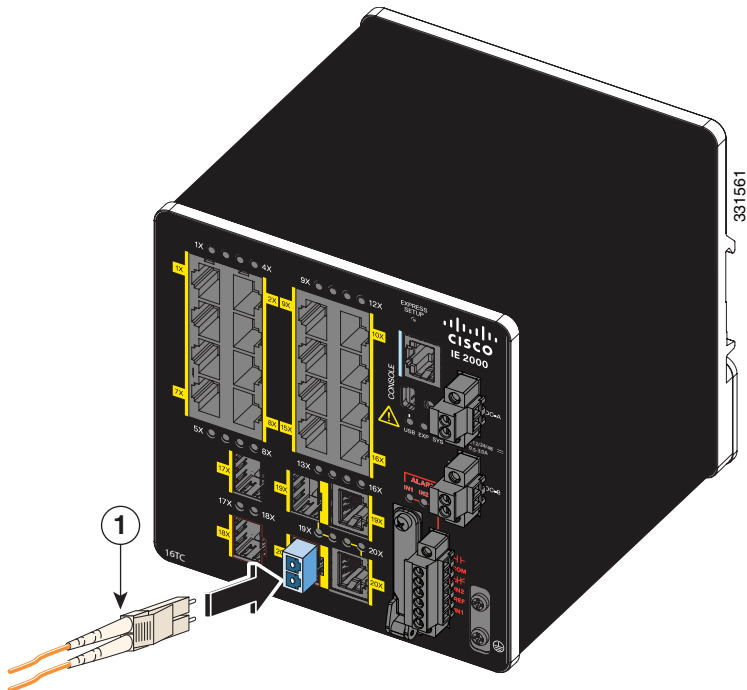

1 LC connector

3. Insert the other cable end into a fiber-optic receptacle on a target device.

4. Observe the port status LED:

- The LED turns green when the switch and the target device have an established link.
- The LED turns amber while the STP discovers the network topology and searches for loops. This process takes about 30 seconds, and then the port LED turns green.
- If the LED is off, the target device might not be turned on, there might be a cable problem, or there might be a problem with the adapter installed in the target device. See [Troubleshooting, page 75](#) for solutions to cabling problems.

5. If necessary, reconfigure and restart the switch or the target device.

Connecting to a 1000BASE-T SFP Module

Follow these steps to connect a CAT5 cable to a 1000BASE-T SFP module:

1. When connecting to servers, workstations, and routers, insert a four twisted-pair, straight-through cable in the RJ-45 connector. When connecting to switches or repeaters, insert a four twisted-pair, crossover cable.

When connecting to a 1000BASE-T device, use a four twisted-pair CAT5 cable.

2. Insert the other cable end in an RJ-45 connector on a target device.

3. Observe the port status LED.

- The LED turns green when the switch and the target device have an established link.

-
- The LED turns amber while the STP discovers the network topology and searches for loops. This process takes about 30 seconds, and then the port LED turns green.
 - If the LED is off, the target device might not be turned on, there might be a cable problem, or there might be problem with the adapter installed in the target device. See [Troubleshooting, page 75](#) for solutions to cabling problems.

4. If necessary, reconfigure and restart the switch or target device.

Connecting to a Dual-Purpose Port

The dual-purpose port is a single port with two interfaces, one for an RJ-45 cable and another for an SFP module. Only one interface can be active at a time. If both interfaces are connected, the SFP module has priority. For more information about dual-purpose ports, see [Power Connectors, page 17](#).

Warning: Class 1 laser product. Statement 1008

Caution: Do not remove the rubber plugs from the SFP module port or the rubber caps from the fiber-optic cable until you are ready to connect the cable. The plugs and caps protect the SFP module ports and cables from contamination and ambient light.

Caution: Before connecting to the SFP module, be sure that you understand the port and cabling stipulations in [Preparing for Installation, page 29](#). See [Cable and Connectors, page 87](#) for information about the LC on the SFP module.

To connect to a dual-purpose port, follow these steps:

1. Connect an RJ-45 connector to the 10/100/1000 port, or install an SFP module into the SFP module slot, and connect a cable to the SFP module port. See [Figure 44 on page 73](#).

For more information about RJ-45 connections, SFP modules, and optical connections, see [Connecting to 10/100 and 10/100/1000 Ports, page 64](#), [Installing and Removing SFP Modules, page 66](#), and [Connecting to SFP Modules, page 70](#).

Figure 44 Connecting to a Dual-Purpose Port

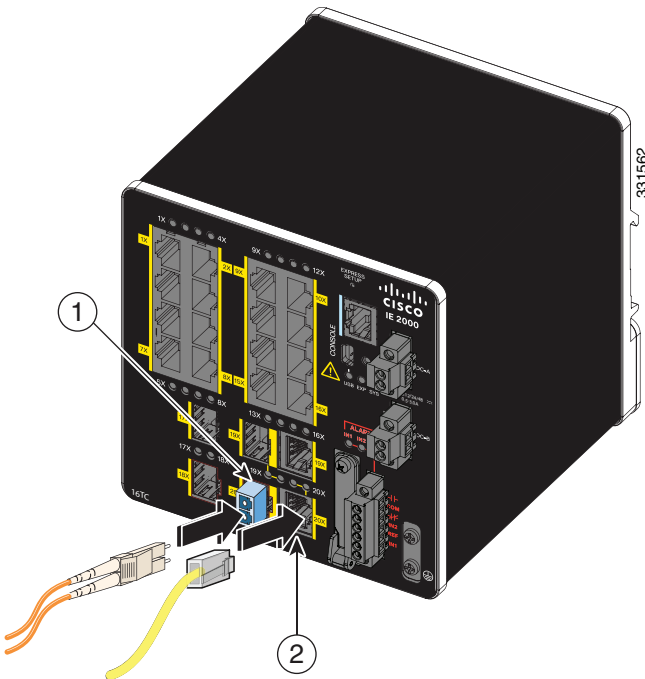

- 1 LC connector (optical) 2 RJ-45 connector (copper)

2. Connect the other end of the cable to the other device.

By default, the switch detects whether an RJ-45 connector or SFP module is connected to a dual-purpose port and configures the port accordingly. You can change this setting and configure the port to recognize only an RJ-45 connector or only an SFP module by using the **media type** interface configuration command. For more information, see the *Cisco IE 2000 Switch Command Reference*.

Verifying Switch Operation

Before installing the switch in its final location, power on the switch, and verify that the switch powers up in boot fast style. The boot fast sequence allows the switch to boot up in less than 60 seconds.

Where to Go Next

If the default configuration is satisfactory, the switch does not need further configuration. You can use any of these management options to change the default configuration:

- Start Device Manager, which is in the switch memory, to manage individual and standalone switches. This is an easy-to-use web interface that offers quick configuration and monitoring. You can access Device Manager from anywhere in your network through a web browser. For more information, see [Running Express Setup, page 97](#) and the Device Manager online help.
- Start the Cisco Network Assistant application, which is described in the *Getting Started with Cisco Network Assistant* guide. Using the GUI, you can configure and monitor a switch cluster or an individual switch.

-
- Use the CLI to configure the switch as an individual switch from the console. See the *Command Reference* on Cisco.com for information about using the CLI.
 - Start an SNMP application such as the CiscoView application.
 - Start the Common Industrial Protocol (CIP) management tool. You can manage an entire industrial automation system with the CIP-based tools.



Troubleshooting

This chapter provides these topics for troubleshooting problems:

- [Diagnosing Problems, page 75](#)
- [How to Recover Passwords, page 78](#)
- [Finding the Switch Serial Number, page 78](#)

Diagnosing Problems

The switch LEDs provide troubleshooting information about the switch. They show boot fast failures, port-connectivity problems, and overall switch performance. You can also get statistics from Device Manager, the CLI, or an SNMP workstation. See the *Cisco IE 2000 Switch Software Configuration Guide*, the *Cisco IE 2000 Switch Command Reference* on Cisco.com, or the documentation that came with your SNMP application for details.

Switch Boot Fast

See [Verifying Switch Operation, page 73](#) for information on boot fast.

Note: Boot fast failures are usually fatal. Contact your Cisco TAC representative if your switch does not successfully complete boot fast.

Note: You can disable the boot fast and run POST by using the Cisco IOS CLI, see the *Cisco IE 2000 Switch Software Configuration Guide* and the *Cisco IE 2000 Switch Command Reference* for more information.

Switch LEDs

Look at the port LEDs information when troubleshooting the switch. See [LEDs, page 20](#) for a description of the LED colors and their meanings.

Switch Connections

Bad or Damaged Cable

Always examine the cable for marginal damage or failure. A cable might be just good enough to connect at the physical layer, but it could corrupt packets as a result of subtle damage to the wiring or connectors. You can identify this problem because the port has many packet errors or it constantly flaps (loses and regains link).

- Exchange the copper or fiber-optic cable with a known good cable.
- Look for broken or missing pins on cable connectors.
- Rule out any bad patch panel connections or media converters between the source and the destination. If possible, bypass the patch panel, or eliminate media converters (fiber-optic-to-copper).
- Try the cable in another port to see if the problem follows the cable.

Ethernet and Fiber-Optic Cables

Ensure that you have the correct cable:

- For Ethernet, use Category 3 copper cable for 10 Mb/s UTP connections. Use either CAT5, CAT5e, or CAT6 UTP for 10/100, 10/100/1000 Mb/s, and PoE connections.
- Verify that you have the correct fiber-optic cable for the distance and port type. Make sure that the connected device ports match and use the same type encoding, optical frequency, and fiber type.
- Determine if a copper crossover cable was used when a straight-through was required or the reverse. Enable auto-MDIX on the switch, or replace the cable.

Link Status

Verify that both sides have a link. A broken wire or a shutdown port can cause one side to show a link even though the other side does not have a link.

A port LED that is on does not guarantee that the cable is functional. It might have encountered physical stress, causing it to function at a marginal level. If the port LED does not turn on:

- Connect the cable from the switch to a known good device.
- Make sure that both ends of the cable are connected to the correct ports.
- Verify that both devices have power.
- Verify that you are using the correct cable type. See [Cables and Adapters, page 90](#) for information.
- Look for loose connections. Sometimes a cable appears to be seated but is not. Disconnect the cable, and then reconnect it.

10/100 and 10/100/1000 Port Connections

If a port appears to malfunction:

- Verify the status of all ports by checking the LEDs. For more information, see [Switch LEDs, page 75](#).
- Use the **show interfaces** privileged EXEC command to see if the port is error-disabled, disabled, or shut down. Reenable the port if necessary.
- Verify the cable type. See [Cable and Connectors, page 87](#).

SFP Module

Use only Cisco SFP modules. Each Cisco module has an internal serial EEPROM that is encoded with security information. This encoding verifies that the module meets the requirements for the switch.

- Inspect the SFP module. Exchange the suspect module with a known good module.
- Verify that the module is supported on this platform. (The switch release notes on Cisco.com list the SFP modules that the switch supports.)
- Use the **show interfaces** privileged EXEC command to see if the port or module is error-disabled, disabled, or shutdown. Reenable the port if needed.
- Ensure that all fiber-optic connections are clean and securely connected.

Interface Settings

Verify that the interface is not disabled or powered off. If an interface is manually shut down on either side of the link, it does not come up until you re-enable the interface. Use the **show interfaces** privileged EXEC command to see if the interface is error-disabled, disabled, or shut down on either side of the connection. If needed, re-enable the interface.

Ping End Device

Ping from the directly connected switch first, and then work your way back port by port, interface by interface, trunk by trunk, until you find the source of the connectivity issue. Make sure that each switch can identify the end device MAC address in its Content-Addressable Memory (CAM) table.

Spanning Tree Loops

STP loops can cause serious performance issues that look like port or interface problems.

A unidirectional link can cause loops. It occurs when the traffic sent by the switch is received by the neighbor, but the traffic from the neighbor is not received by the switch. A broken cable, other cabling problems, or a port issue can cause this one-way communication.

You can enable UniDirectional Link Detection (UDLD) on the switch to help identify unidirectional link problems. For information about enabling UDLD on the switch, see the “Understanding UDLD” section in the switch software configuration guide on Cisco.com.

Switch Performance

Speed, Duplex, and Autonegotiation

Port statistics that show a large amount of alignment errors, frame check sequence (FCS), or late-collisions errors, might mean a speed or duplex mismatch.

A common issue occurs when duplex and speed settings are mismatched between two switches, between a switch and a router, or between the switch and a workstation or server. Mismatches can happen when manually setting the speed and duplex or from autonegotiation issues between the two devices.

To maximize switch performance and to ensure a link, follow one of these guidelines when changing the duplex or the speed settings.

- Let both ports autonegotiate both speed and duplex.
- Manually set the speed and duplex parameters for the interfaces on both ends of the connection.
- If a remote device does not autonegotiate, use the same duplex settings on the two ports. The speed parameter adjusts itself even if the connected port does not autonegotiate.

Autonegotiation and Network Interface Cards

Problems sometimes occur between the switch and third-party network interface cards (NICs). By default, the switch ports and interfaces autonegotiate. Laptops or other devices are commonly set to autonegotiate, yet sometimes issues occur.

To troubleshoot autonegotiation problems, try manually setting both sides of the connection. If this does not solve the problem, there could be a problem with the firmware or software on the NIC. You can resolve this by upgrading the NIC driver to the latest version.

Cabling Distance

If the port statistics show excessive FCS, late-collision, or alignment errors, verify that the cable distance from the switch to the connected device meets the recommended guidelines. See [Cables and Adapters, page 90](#).

Resetting the Switch

These are reasons why you might want to reset the switch to the factory default settings:

- You installed the switch in your network and cannot connect to it because you assigned the wrong IP address.
- You want to reset the password on the switch.

Note: Resetting the switch deletes the configuration and reboots the switch.

Caution: If you press the Express Setup button when you power on, the automatic boot sequence stops, and the switch enters bootloader mode.

To reset the switch:

1. Press and hold the Express Setup button for about 10 seconds. The switch reboots. The system LED turns green after the switch completes rebooting.
2. Press the Express Setup button again for 3 seconds. A switch 10/100 Ethernet port blinks green.

The switch now behaves like an unconfigured switch. You can configure the switch by using the CLI setup procedure described in [Configuring the Switch with the CLI-Based Setup Program, page 101](#). You can also configure the switch by using Express Setup as described in [Running Express Setup, page 97](#).

How to Recover Passwords

Password recovery is a feature that a system administrator can enable or disable. If password recovery is disabled, the only way to recover from a lost or forgotten password is to clear the switch configuration entirely. For this procedure, see [How to Recover Passwords, page 78](#).

The *Cisco IE 2000 Switch Software Configuration Guide* provides details about enabling and disabling the password recovery feature and the procedure for recovering passwords.

Finding the Switch Serial Number

If you contact Cisco Technical Assistance, you need to know the serial number of your switch. The serial number is on the compliance label on the right-hand side of the switch. See [Figure 45 on page 79](#). You can also use the **show version** privileged EXEC command to obtain the switch serial number.

Figure 45 Serial Number Location for the Cisco IE-2000 Switches

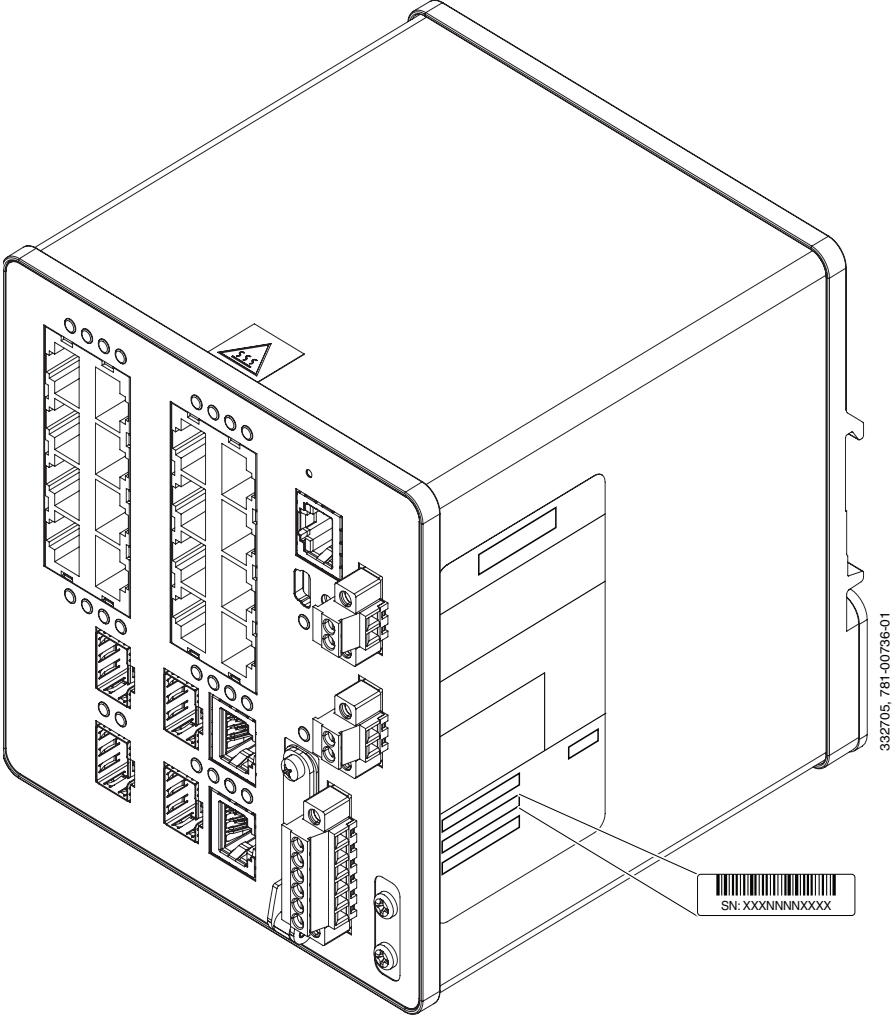



Technical Specifications

This appendix provides the technical specification for the Cisco IE 2000 switches.

Operating Temperature Specifications

Table 14 on page 81 lists the operating temperatures for the Cisco IE 2000 switches in three different environments.

Table 14 Operating Temperature for the Cisco IE 2000 Switches

	Industrial Automation and Hazardous Locations	Substation	Traffic Signal
Enclosure types	Sealed enclosures For example: NEMA4, NEMA4X, NEMA12, NEMA13, IP54, and IP66.	Vented enclosures For example: NEMA1, IP20, and IP21.	Fan or blower-equipped enclosures For example: NEMA TS-2. Note: The minimum airflow is 150 lfm ¹ .
¹ lfm = linear feet per minute.			

The safety certifications apply only to ambient temperatures under 140°F (60°C). However, the Cisco IE 2000 switch can function in the substation and traffic signal installations under the environmental conditions shown in Table 14 on page 81.

Technical Specifications

Table 15 on page 81 lists the technical specifications for the Cisco IE 2000 switches.

Table 15 Cisco IE 2000 Series Technical Specifications

Environmental Ranges	
Operating temperature ¹	-40C to +74C n -40C to +70C (Vented Enclosure Operating) n -40C to +60C (Sealed Enclosure Operating) n -34C to +74C (100LFM or more Fan or Blower equipped Enclosure Operating) n -40C to +85C (Type Tested to +85C for 16 hours) ²
Storage temperature	-40 to 185° F (-40 to 85° C)
Operating humidity	5 to 95% (non-condensing)
Operating shock	30 g at 11 ms
Operating altitude	Up to 13,000 ft (3962 m)
Storage altitude	Up to 40,000 ft (12,192 m)

Table 15 Cisco IE 2000 Series Technical Specifications (continued)

Power Requirements	
DC input voltage	<ul style="list-style-type: none"> ■ Maximum operating range: 9.6 to 60 VDC ■ Nominal: 12, 24, or 48 VDC ■ The DC-input power supply is an SELV circuit, and it can only be connected to another SELV circuit. ■ Input voltage for power supplies: <ul style="list-style-type: none"> – To power the switch, PWR-IE50W-AC-IEC and PWR-IE50W-AC provide 24 VDC at 2.1 A. – To support PoE, power supplies PWR-IE65W-PC-AC and PWR-IE65W-PC-DC provide 54 VDC at 1.2 A. ■ The IE 2000 switch models with PoE capability are equipped with an additional DC input terminal block that allows the connection of a second power supply or a second input from site source DC power to operate the PoE ports. The PoE terminal block accepts 48 VDC or 54 VDC at up to 2.5 A, depending on the amount of power that is provided to the connected devices. <ul style="list-style-type: none"> – PoE mode: 48 VDC (nominal)/44-57 VDC (absolute range) – PoE+ mode: 54 VDC (nominal)/50-57 VDC (absolute range)
Maximum DC input current	<ul style="list-style-type: none"> ■ 1 A @ 48 VDC ■ 2 A @ 24 VDC ■ Switch models with PoE capability: 48 VDC or 54 VDC at 2.5 A
Power consumption ¹	<p>6-port models—9.5 W (typical), 15 W (maximum)</p> <ul style="list-style-type: none"> ■ Cisco IE-2000-4T-L ■ Cisco IE-2000-4T-B ■ Cisco IE-2000-4T-G-L ■ Cisco IE-2000-4T-G-B ■ Cisco IE-2000-4TS-L ■ Cisco IE-2000-4TS-B ■ Cisco IE-2000-4TS-G-L ■ Cisco IE-2000-4TS-G-B <p>6-port models—12W (typical), 18W (maximum)</p> <ul style="list-style-type: none"> ■ Cisco IE-2000-4S-TS-G-L ■ Cisco IE-2000-4S-TS-G-B

Table 15 Cisco IE 2000 Series Technical Specifications (continued)

<p>Power consumption¹ (continued)</p>	<p>10-port models—12.5 W (typical), 17 W (maximum)</p> <ul style="list-style-type: none"> ■ Cisco IE-2000-8TC-L ■ Cisco IE-2000-8TC-B ■ Cisco IE-2000-8TC-G-L ■ Cisco IE-2000-8TC-G-B ■ Cisco IE-2000-8TC-G-N <p>10-port models—15 W (typical), 20 W (maximum)</p> <ul style="list-style-type: none"> ■ Cisco IE-2000-8TC-G-E <hr/> <p>18-port models—11 W (typical), 18 W (maximum)</p> <ul style="list-style-type: none"> ■ Cisco IE-2000-16PTC-G-E ■ Cisco IE-2000-16PTC-G-L ■ Cisco IE-2000-16PTC-G-NX <hr/> <p>20-port models—21 W (typical), 30 W (maximum)</p> <ul style="list-style-type: none"> ■ Cisco IE-2000-16TC-L ■ Cisco IE-2000-16TC-B ■ Cisco IE-2000-16TC-G-L ■ Cisco IE-2000-16TC-G-E ■ Cisco IE-2000-16TC-G-N ■ Cisco IE-2000-16TC-G-X
<p>Physical Dimensions</p>	
<p>Weight</p>	<p>6-port models—2.45 lbs (1.11 kg)</p> <ul style="list-style-type: none"> ■ Cisco IE-2000-4T-L ■ Cisco IE-2000-4T-B ■ Cisco IE-2000-4T-G-L ■ Cisco IE-2000-4T-G-B ■ Cisco IE-2000-4TS-L ■ Cisco IE-2000-4TS-B ■ Cisco IE-2000-4TS-G-L ■ Cisco IE-2000-4TS-G-B ■ Cisco IE-2000-4S-TS-G-L ■ Cisco IE-2000-4S-TS-G-B

Table 15 Cisco IE 2000 Series Technical Specifications (continued)

<p>Weight (continued)</p>	<p>10-port models—2.75 lbs (1.25 kg)</p> <ul style="list-style-type: none"> ■ Cisco IE-2000-8TC-L ■ Cisco IE-2000-8TC-B ■ Cisco IE-2000-8TC-G-L ■ Cisco IE-2000-8TC-G-B ■ Cisco IE-2000-8TC-G-N <p>10-port models—3.45 lbs (1.57 kg)</p> <ul style="list-style-type: none"> ■ Cisco IE-2000-8TC-G-E <hr/> <p>18- and 20-port models: 4.35 lbs (1.98 kg)</p> <ul style="list-style-type: none"> ■ Cisco IE-2000-16PTC-G-E ■ Cisco IE-2000-16PTC-G-L ■ Cisco IE-2000-16PTC-G-NX ■ Cisco IE-2000-16TC-L ■ Cisco IE-2000-16TC-B ■ Cisco IE-2000-16TC-G-L ■ Cisco IE-2000-16TC-G-E ■ Cisco IE-2000-16TC-G-N ■ Cisco IE-2000-16TC-G-X
<p>Dimensions ² (H x W x D) including DIN rail</p>	<p>6-port models—5.1 x 2.95 x 4.51 in. (12.7 x 7.37 x 11.46 cm)</p> <ul style="list-style-type: none"> ■ Cisco IE-2000-4S-TS-G-L ■ Cisco IE-2000-4S-TS-G-B ■ Cisco IE-2000-4T-L ■ Cisco IE-2000-4T-B ■ Cisco IE-2000-4T-G-L ■ Cisco IE-2000-4T-G-B ■ Cisco IE-2000-4TS-L ■ Cisco IE-2000-4TS-B

Table 15 Cisco IE 2000 Series Technical Specifications (continued)

Dimensions ² (H x W x D) including DIN rail (continued)	10-port models—5.1 x 3.6 x 4.51 in. (12.7 x 8.89 x 11.46 cm)
	<ul style="list-style-type: none"> ■ Cisco IE-2000-8TC-L ■ Cisco IE-2000-8TC-B ■ Cisco IE-2000-8TC-G-L ■ Cisco IE-2000-8TC-G-B ■ Cisco IE-2000-8TC-G-N
	10-port models—5.1 x 3.6 x 5.26 in. (12.7 x 8.89 x 13.36 cm)
	<ul style="list-style-type: none"> ■ Cisco IE-2000-8TC-G-E
	18-port and 20-port models—5.1 x 5.0 x 5.26 in. (12.7 x 12.45 x 13.36 cm)
	<ul style="list-style-type: none"> ■ Cisco IE-2000-16TC-L ■ Cisco IE-2000-16TC-B ■ Cisco IE-2000-16TC-G-L ■ Cisco IE-2000-16TC-G-E ■ Cisco IE-2000-16TC-G-N ■ Cisco IE-2000-16TC-G-X ■ Cisco IE-2000-16PTC-G-E ■ Cisco IE-2000-16PTC-G-L ■ Cisco IE-2000-16PTC-G-NX

¹Typical power consumption is with a 24 VDC input voltage at a 40°C (104°F) ambient temperature. Maximum power consumption is the extreme level at any operational DC input voltage over the entire operating temperature range.

² To calculate the depth excluding the rail, subtract 0.22 in. (0.6 cm).

1. Operating temperatures exceeding 60C are not covered by the product safety certifications and approvals. However, the switch can function in the installations under the environmental conditions listed.

2. The maximum operating temperature of the switch varies depending on the type of SFP module that you use.

Alarm Ratings

Table 16 on page 85 lists the alarm ratings for the Cisco IE 2000 switches.

Table 16 Alarm Input and Output Ratings

Alarm Ratings	Specification
Alarm input electrical specification	No power required—open or closed state detected.
Alarm output electrical specification	1.0 A @ 24 VDC or 0.5 A @ 48 VDC

Hazardous Locations Standards

Table 17 on page 86 lists the hazardous location standards for the Cisco IE 2000 switches.

Table 17 Hazardous Locations Standards

The following standards were used for the hazardous locations approvals and certifications:	Les normes suivantes ont été appliquées pour les approbations et les certifications dans le cadre d'environnements dangereux :
ANSI/ASA 12.12.01-2013	ANSI/ASA 12.12.01-2013
CAN/CSA C22.2 No. 60079-0: 11	CAN/CSA C22.2 n° 60079-0 : 11
CAN/CSA C22.2 No. 60079-15:12	CAN/CSA C22.2 n° 60079-15 :12
CSA C22.2 No. 213-M1987	CSA C22.2 n° 213-M1987
EN 60079-0:2012	EN 60079-0:2012
EN 60079-15:2010	EN 60079-15:2010
IEC 60079-0 6th Edition	IEC 60079-0, 6e édition
IEC 60079-15 4th Edition	IEC 60079-15, 4e édition
UL 60079-0, 5th Ed, 2009-10-21	UL 60079-0, 5e éd., 21-10-2009
UL 60079-15, 3rd Ed, 2009-7-17	UL 60079-15, 3e éd., 17-07-2009



Cable and Connectors

- [Connector Specifications, page 87](#)
- [Cables and Adapters, page 90](#)

Connector Specifications

- [10/100 Ports, page 87](#)
- [SFP Module Connectors, page 88](#)
- [Dual-Purpose Ports, page 88](#)
- [Alarm Port, page 89](#)

10/100 Ports

The 10/100 Ethernet ports on the switches use RJ-45 connectors. [Figure 46 on page 87](#) shows the pinouts.

Figure 46 10/100 Port Pinouts

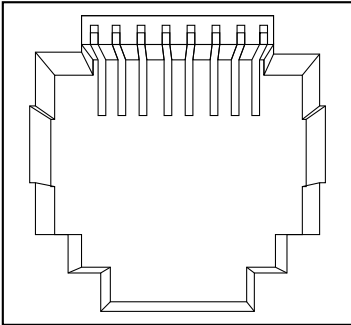
Pin	Label	1	2	3	4	5	6	7	8
1	RD+								
2	RD-								
3	TD+								
4	NC								
5	NC								
6	TD-								
7	NC								
8	NC								

For the three models of IE 2000 switch that support PoE, connector pins 4 and 5 supply +48 VDC and pins 7 and 8 are the DC voltage return lines.

SFP Module Connectors

Figure 47 on page 88 shows the MT-RJ SFP module fiber-optic local connector (LC).

Figure 47 Fiber-Optic SFP Module LC Connector

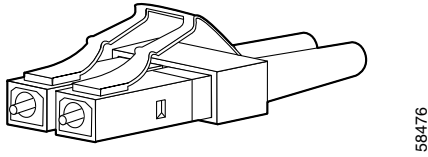

Warning: Invisible laser radiation may be emitted from disconnected fibers or connectors. Do not stare into beams or view directly with optical instruments. Statement 1051

Figure 48 on page 88 shows the 1000BASE-T SFP module RJ-45 connector.

Figure 48 1000BASE-T SFP Module Connector

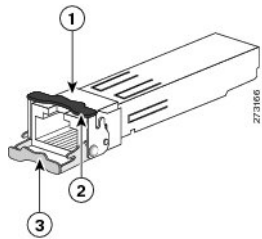

- 1 RJ-45 connector
- 2 Bale-clasp latching mechanism in the closed (locked) position
- 3 Bale-clasp latching mechanism in the open (unlocked) position

Dual-Purpose Ports

The 10/100/1000 Ethernet ports on the dual-purpose ports use RJ-45 connectors. Figure 49 on page 88 shows the pinouts.

Figure 49 10/100/1000 Port Pinouts

Pin	Label	1	2	3	4	5	6	7	8
1	TP0+								
2	TP0-								
3	TP1+								
4	TP2+								
5	TP2-								
6	TP1-								
7	TP3+								
8	TP3-								

Console Port

The switch has two console ports: a USB 5-pin mini-Type B port on the front panel (see [Figure 50 on page 89](#)) and an RJ-45 console port on the rear panel.

Figure 50 USB Mini-Type B Port

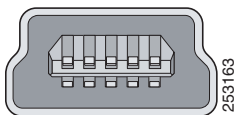

The USB console port uses a USB Type A to 5-pin mini-Type B cable, shown in [Figure 51 on page 89](#). The USB Type A-to-USB mini-Type B cable is not supplied. You can order an accessory kit (part number 800-33434) that contains this cable.

Figure 51 USB Type A-to-USB 5-Pin Mini-Type B Cable

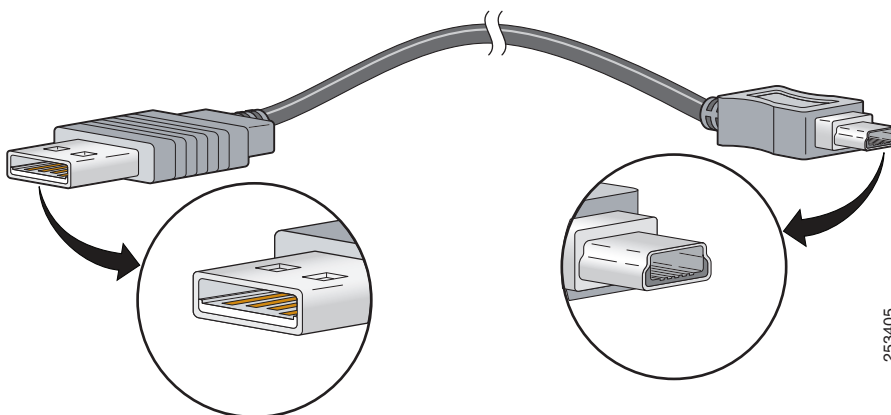

The RJ-45 console port uses an 8-pin RJ-45 connector (see [Table 22 on page 95](#) and [Table 23 on page 95](#)). The supplied RJ-45-to-DB-9 adapter cable is used to connect the console port of the switch to a console PC. You need to provide an RJ-45-to-DB-25 female DTE adapter if you want to connect the switch console port to a terminal. You can order a kit (part number ACS-DSBUASYN=) containing that adapter. For console port and adapter pinout information, see [Table 22 on page 95](#) and [Table 23 on page 95](#).

Alarm Port

For information on alarm ratings, see [Alarm Ratings, page 85](#).

The labels for the alarm connector pin-outs are on the switch panel and are displayed in [Table 18 on page 89](#).

Table 18 Alarm Connector Labels (Top to Bottom)

Label	Connection
NO	Alarm Output Normally Open (NO) connection
COM	Alarm Output Common connection
NC	Alarm Output Normally Closed (NC) connection
IN2	Alarm Input 2
REF	Alarm Input Reference Ground connection
IN1	Alarm Input 1

Cables and Adapters

- [SFP Module Cables, page 90](#)
- [Cable Pinouts, page 93](#)
- [Console Port Adapter Pinouts, page 94](#)

SFP Module Cables

Each port must match the wave-length specifications on each end of the cable, and for reliable communications, the cable must not exceed the allowable length. Copper 1000BASE-T SFP transceivers use standard four twisted-pair, CAT5 (or greater) cable at lengths up to 328 feet (100 meters).

Notes

- The maximum operating temperature of the switch varies depending on SFP module type. See [Table 2 on page 19](#) for supported temperature ranges.
- Modal bandwidth applies only to multimode fiber (MMF).
- A mode-field diameter/cladding diameter = 9 micrometers/125 micrometers.
- 1000BASE-LX/LH SFP modules connected with MMF over a short link distance require a mode-conditioning patch cord.

Ordinary patch cords can cause transceiver saturation, resulting in an elevated bit error rate (BER). Using the 1000BASE-LX/LH SFP module with 62.5-micron diameter multimode fiber (MMF) requires a mode-conditioning patch cord between the single mode fiber (SMF) SFP module and the MMF cable on both the send and receive link ends.

- Link distances greater than 984 feet (300 m) require a mode-conditioning patch cord.
- 1000BASE-ZX SFP modules can send data up to 62 miles (100 km) by using dispersion-shifted SMF or low-attenuation SMF. The distance depends on fiber quality, the number of splices, and the connectors.
- Fiber-optic cable spans less than 15.43 miles (25 km) require a 5-decibel (dB) or 10-dB inline optical attenuator between the fiber-optic cable plant and the receiving port on the 1000BASE-ZX SFP module.

Table 19 Industrial and Rugged SFPs—Fiber-Optic SFP Module Port Cabling Specifications

Type of SFP Module	Model	Wavelength (nanometers)	Fiber Type	Core Size/Cladding Size (micron)	Modal Bandwidth (MHz/km)	Cable Distance
1000BASE-LX/LH	GLC-LX-SM-RGD	1310	M	62.5	500	1804 feet (550 m)
			SMF	50.0	400	1804 feet (550 m)
				50.0	500	1804 feet (550 m)
				G.652	—	6.2 miles (10 km)
1000BASE-SX	GLC-SX-MM-RGD	850	MMF	62.5/125	160	722 feet (220 m)
				62.5/125	200	902 feet (275 m)
				50/125	400	1640 feet (500 m)
				50/125	500	1804 feet (550 m)
1000BASE-ZX	GLC-ZX-SM-RGD	1550	SMF	G.652	—	43.4 to 62 miles (70 to 100 km)

Table 19 Industrial and Rugged SFPs–Fiber-Optic SFP Module Port Cabling Specifications (continued)

Type of SFP Module	Model	Wavelength (nanometers)	Fiber Type	Core Size/Cladding Size (micron)	Modal Bandwidth (MHz/km)	Cable Distance
100BASE-FX	GLC-FE-100FX-RGD	1310	MMF	62.5/125 62.5/125 50/125 50/125	160 200 400 500	1.24 miles (2 km)
100BASE-LX10	GLC-FE-100LX-RGD	1310	SMF	G.652	–	6.2 miles (10 km)
1000BASE-BX-D	GLC-BX40-D-I GLC-BX40-DA-I GLC-BX80-D-I)	1550 1490 1570	SMF	G.652	–	24.9 miles (40 km) 24.9 miles (40 km) 49.8 miles (80 km)
1000BASE-BX-U	GLC-BX40-U-I GLC-BX80-U-I	1310 1490	SMF	G.652	–	24.9 miles (40 km) 49.8 miles (80 km)

Table 20 Commercial SFPs–Fiber-Optic SFP Module Port Cabling Specifications

Type of SFP Module	Model	Wavelength (nanometers)	Fiber Type	Core Size/Cladding Size (micron)	Modal Bandwidth (MHz/km)	Cable Distance
1000BASE-BX10-D	GLC-BX-D	1490 TX 1310 RX	SMF	G.652	–	6.2 miles (10 km)
1000BASE-BX10-U	GLC-BX-U	1490 TX 1310 RX	SMF	G.652	–	6.2 miles (10 km)
1000BASE-LX/LH	GLC-LH-SM	1310	MMF SMF	62.5/125 50/125 50/125 G.652	500 400 500 –	1804 feet (550 m) 1804 feet (550 m) 1804 feet (550 m) 6.2 miles (10 km)
1000BASE-SX	GLC-SX-MM	850	MMF	62.5/125 62.5/125 50/125 50/125	160 200 400 500	722 feet (220 m) 902 feet (275 m) 1640 feet (500 m) 1804 feet (550 m)
100BASE-BX10-D	GLC-FE-100BX-D	1310 TX 1550 RX	SMF	G.652	–	6.2 miles (10 km)
100BASE-BX10-U	GLC-FE-100BX-U	1310 TX	SMF	G.652	–	6.2 miles (10 km)
100BASE-EX	GLC-FE-100EX	1310	SMF	G.652	–	24.9 miles (40 km)
100BASE-FX SFP	GLC-FE-100FX	1310	MMF	50/125 62.5/125	500	6562 feet (2 km)
100BASE-LX10	GLC-FE-100LX	1310	SMF	G.652	–	6.2 miles (10 km)
100BASE-ZX	GLC-FE-100ZX	1550	SMF	G.652	–	49.7 miles (80 km)

Table 20 Commercial SFPs–Fiber-Optic SFP Module Port Cabling Specifications (continued)

Type of SFP Module	Model	Wavelength (nanometers)	Fiber Type	Core Size/ Cladding Size (micron)	Modal Bandwidth (MHz/km)	Cable Distance
1000BASE-CWDM	CWDM	1470, 1490, 1510, 1530, 1550, 1570, 1590, 1610	SMF	G.652	–	62 miles (100 km)
1000BASE-DWDM	DWDM	1530.33, 1531.12, 1531.90, 1532.68, 1534.25, 1535.04, 1535.82, 1538.19, 1539.77, 1539.98, 1539.77, 1540.56, 1542.14, 1542.94, 1544.53, 1546.12, 1546.92, 1547.72, 1548.51, 1550.12, 1550.92, 1551.72, 1552.52, 1554.13, 1554.94, 1555.75, 1556.55, 1558.17, 1558.98, 1559.79, 1560.61	SMF	G.652	–	62 miles (100 km)
1000BASE-T	GLC-T	–	MMF	–	–	328 ft. (100 m)

View the CWDM data sheet at

http://www.cisco.com/en/US/prod/collateral/modules/ps5455/ps6575/product_data_sheet09186a00801a557c_ps4999_Products_Data_Sheet.html

View the DWDM data sheet at

http://www.cisco.com/en/US/prod/collateral/modules/ps5455/ps6576/product_data_sheet0900aecd80582763.html

Table 21 Extended Temperature SFPs–Fiber-Optic SFP Module Port Cabling Specifications

Type of SFP Module	Model	Wavelength (nanometers)	Fiber Type	Core Size/ Cladding Size (micron)	Modal Bandwidth (MHz/km)	Cable Distance
1000BASE-LX/LH	SFP-GE-L	1300	MMF or SMF	62.2 50 50 9/10	500 400 500 –	1804 feet (550 m) 1804 feet (550 m) 1804 feet (550 m) 6.2 miles (10 km)
1000BASE-LX/LH	GLC-LH-SMD	1310	MMF SMF	62.5 50.0 50.0 G.652	500 400 500 –	1804 feet (550 m) 1804 feet (550 m) 1804 feet (550 m) 6.2 miles (10 km)
1000BASE-EX	GLC-EX-SMD	1310	SMF	G.652	–	24.9 miles (40 km)

Table 21 Extended Temperature SFPs–Fiber-Optic SFP Module Port Cabling Specifications (continued)

Type of SFP Module	Model	Wavelength (nanometers)	Fiber Type	Core Size/ Cladding Size (micron)	Modal Bandwidth (MHz/km)	Cable Distance
1000BASE-SX	SFP-GE-S	850	MMF	62.5 62.5 50.0 50.0	160 200 400 500	722 feet (220 m) 902 feet (275 m) 1640 feet (500 m) 1804 feet (550 m)
1000BASE-SX	GLC-SX-MMD	850	MMF	62.5 62.5 50.0 50.0 50.0	160 200 400 500 2000	722 feet (220 m) 902 feet (275 m) 1640 feet (500 m) 1804 feet (550 m) 3281 feet (1 km)
1000BASE-ZX	SFP-GE-Z	1550	SMF SMF	9/10 8	–	43.5 miles (70 km) 62 miles (100 km)

Cable Pinouts

Figure 52 Two Twisted-Pair Straight-Through Cable Schematic for 10/100 Ports

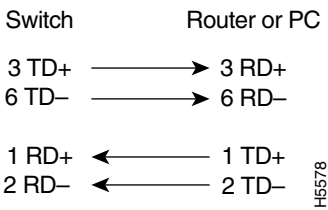

Figure 53 Two Twisted-Pair Crossover Cable Schematic for 10/100 Ports

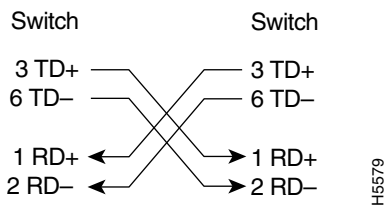

Figure 54 Four Twisted-Pair Straight-Through Cable Schematic for 1000BASE-T Ports

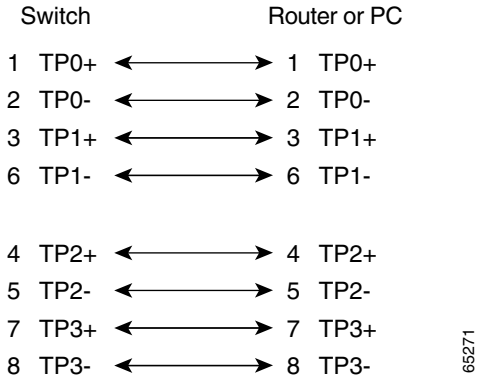
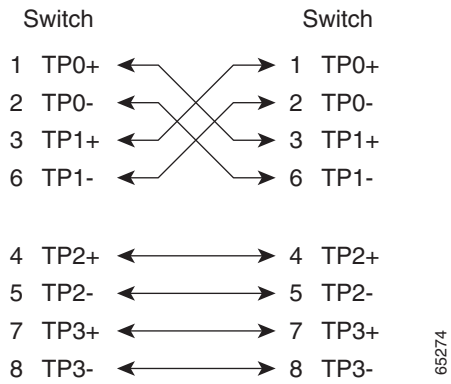
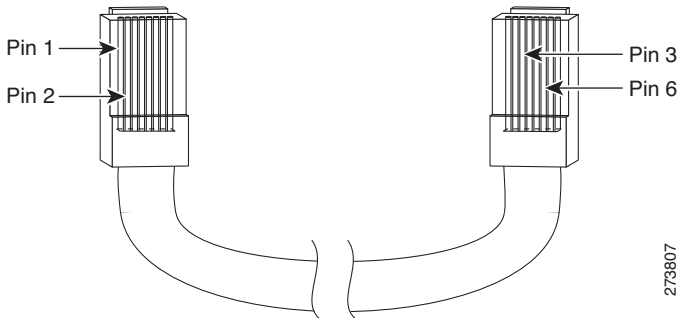

Figure 55 Four Twisted-Pair Crossover Cable Schematics for 1000BASE-T Ports



To identify a crossover cable, hold the cable ends side-by-side, with the tab at the back. The wire connected to pin 1 on the left end should be the same color as the wire connected to pin 3 on the right end. The wire connected to pin 2 on the left end should be the same color as the wire connected to pin 6 on the right end.

Figure 56 Identifying a Crossover Cable



Console Port Adapter Pinouts

The console port uses an 8-pin RJ-45 connector, which is described in b and [Table 23 on page 95](#). If you did not order a console cable, you need to provide an RJ-45-to-DB-9 adapter cable to connect the switch console port to a PC console port. You need to provide an RJ-45-to-DB-25 female DTE adapter if you want to connect the switch console

port to a terminal. You can order an adapter (part number ACS-DSBUASYN=). For console port and adapter pinout information, see [Table 22 on page 95](#) and [Table 23 on page 95](#).

[Table 22 on page 95](#) lists the pinouts for the console port, the RJ-45-to-DB-9 adapter cable, and the console device.

Table 22 Console Port Signaling Using a DB-9 Adapter

Switch Console Port (DTE)	RJ-45-to-DB-9 Terminal Adapter	Console Device
Signal	DB-9 Pin	Signal
RTS	8	CTS
DTR	6	DSR
TxD	2	RxD
GND	5	GND
RxD	3	TxD
DSR	4	DTR
CTS	7	RTS

[Table 23 on page 95](#) lists the pinouts for the switch console port, RJ-45-to-DB-25 female DTE adapter, and the console device.

Note: The RJ-45-to-DB-25 female DTE adapter is not supplied with the switch. You can order this adapter from Cisco (part number ACS-DSBUASYN=).

Table 23 Console Port Signaling Using a DB-25 Adapter

Switch Console Port (DTE)	RJ-45-to-DB-25 Adapter	Console Device
Signal	DB-25 Pin	Signal
RTS	5	CTS
DTR	6	DSR
TxD	3	RxD
GND	7	GND
RxD	2	TxD
DSR	20	DTR
CTS	4	RTS



Running Express Setup

When you first set up the switch, you should use Express Setup to enter the initial IP information. This process enables the switch to connect to local routers and the Internet. You can then access the switch through the IP address for additional configuration.

You need this equipment to set up the switch:

- PC with Windows XP, Vista, or Windows 7
- Web browser (Internet Explorer 6.0, 7.0 or Firefox 1.5, 2.0, 3.0 or later) with JavaScript enabled
- Straight-through or crossover Category 5 or higher grade cable

Before running Express Setup, disable any pop-up blockers or proxy settings on your browser and any wireless client running on your PC.

To run Express Setup:

1. Make sure that nothing is connected to the switch.

During Express Setup, the switch acts as a DHCP server. If your PC has a static IP address, temporarily configure your PC settings to use DHCP before going to the next step.

Note: Write down the static IP address. You will need this IP address in Step 13.

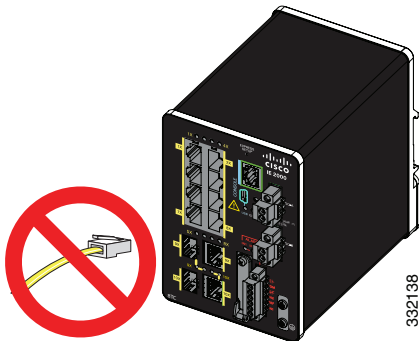

2. Connect power to the switch.

See the wiring instructions in [Grounding the Switch, page 40](#) and [Wiring the DC Power Source, page 46](#).

3. After the switch powers on, it begins the boot fast sequence, which can take up to 60 seconds.

During boot fast, the SYS LED blinks green, and the other LEDs turn green.

When boot fast is complete, the SYS LED turns green, and the other LEDs turn off.

Troubleshooting:

If the SYS LED is off (system not powered on), continues to blink green (POST in progress), or is solid red (Fault), contact the Cisco Technical Assistance Center (TAC). The SYS LED should be solid green when operating normally in Cisco IOS.

4. Press the Express Setup button for 2 to 3 seconds. This button is recessed behind the front panel, so you can use a simple tool, such as a paper clip.

When you press the Express Setup button, a switch port LED begins blinking green.

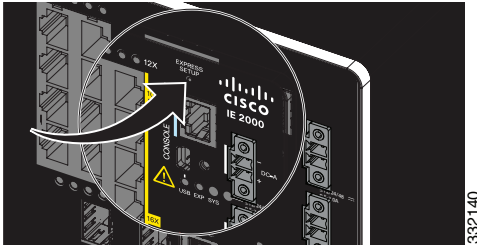

5. Connect a Category 5 Ethernet cable (not provided) from the blinking switch port to the Ethernet port on your PC.

The port LEDs on your PC and on the switch blink green while the switch configures the connection. The green port LEDs indicate a successful connection.

Troubleshooting:

If the port LEDs do not turn green after about 30 seconds, make sure that:

- You connected the Ethernet cable to one of the downlink switch ports (not to an uplink port such as the dual-purpose port).
- You are using an undamaged Category 5 or higher grade cable.
- The other device is turned on.

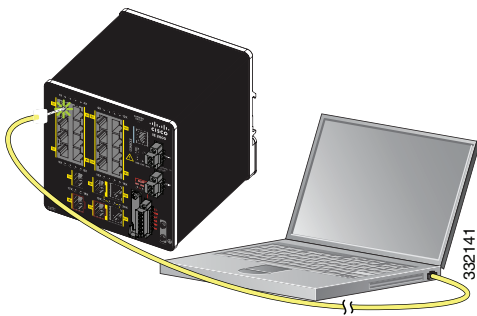

6. When the Setup LED turns solid green, start a browser session on the PC. A login prompt appears.
7. Leave the username blank and enter the default password, *cisco*.

Note: The switch ignores text in the username field.

The Express Setup window appears.

Troubleshooting:

If the Express Setup window does not appear, make sure that any pop-up blockers or proxy settings on your browser are disabled and that any wireless client is disabled on your PC or laptop.

8. Enter all entries in English letters and Arabic numbers.

Required Fields

In the Network Settings fields:

- **Management Interface (VLAN):** We recommend using the default, **VLAN 1**. The management VLAN establishes an IP connection to the switch.

Note: Enter a new VLAN ID only if you want to change the management interface through which you manage the switch. The VLAN ID range is 1 to 1001.

- **IP Assignment Mode:** We recommend using the default, **Static**, so that the switch always has the IP address that you assign. Use the **DHCP** setting when you want the switch to automatically obtain an IP address from a DHCP server.
- **IP Address:** Enter the IP address for the switch. You can later use the IP address to access the switch through Device Manager.
- **Subnet Mask:** Select a mask from the drop-down list.
- **Default Gateway:** Enter the IP address of the router.
- **Switch Password:** Enter a password. The password can be from 1 to 25 alphanumeric characters, can start with a number, is case sensitive, allows embedded spaces, but does not allow spaces at the beginning or end. In the **Confirm Password** field, enter the password again.

Note: You must change the password from the default password, *cisco*.

9. Enter the Control Industrial Protocol (CIP) VLAN settings:

- **CIP VLAN:** Enter the VLAN on which CIP will be enabled. The CIP VLAN can be the same as the management VLAN, or you can isolate CIP traffic on another VLAN that is already configured on the switch. The default CIP VLAN is VLAN 1. Only one VLAN on a switch can have CIP enabled.
- **IP Address:** Enter the IP address for the CIP VLAN. If the CIP VLAN is different from the management VLAN, you must specify an IP address for the CIP VLAN. Make sure that the IP address that you assign to the switch is not being used by another device in your network.
- **Subnet Mask:** Select a mask from the drop-down list.

For more information about the CIP VLAN settings, click **Help** on the toolbar.

10. Optional settings

You can enter the optional information now, or enter it later by using Device Manager. For more information about the Express Setup fields, see the online help for the Express Setup window.

Click **Submit** to save your changes and to complete the initial setup.

For more information about the optional settings, click **Help** on the toolbar.

11. After you click **Submit, these events occur:**

- The switch is configured and exits Express Setup mode.
- The browser displays a warning message and tries to connect with the earlier switch IP address. Typically, connectivity between the PC and the switch is lost because the configured switch IP address is in a different subnet from the IP address on the PC.

-
12. Turn off DC power at the source, disconnect all cables to the switch, and install the switch in your network. See [Management Options, page 26](#) for information about configuring and managing the switch.
 13. If you changed the static IP address on your PC in Step 1, change it to the previously configured static IP address.
 14. You can now manage the switch by using the Cisco Network Assistant, Device Manager, or the Cisco IOS Command Line Interface (CLI). See [Management Options, page 26](#) for information about configuring and managing the switch.

You can display Device Manager by following these steps:

- a. Start a web browser on your PC or laptop.
- b. Enter the switch IP address, username, and password (assigned in Step 7) in the web browser, and press **Enter**. The Device Manager page appears.

Troubleshooting

If the Device Manager page does not appear:

- Confirm that the port LED for the switch port connected to your network is green.
- Confirm that the PC or laptop that you are using to access the switch has network connectivity by connecting it to a well-known web server in your network. If there is no network connection, troubleshoot the network settings on the PC or laptop.
- Make sure that the switch IP address in the browser is correct.
- If the switch IP address in the browser is correct, the switch port LED is green, and the PC or laptop has network connectivity, continue troubleshooting by reconnecting the PC or laptop to the switch. Configure a static IP address on the PC or laptop that is in the same subnet as the switch IP address. For example:
 - If your switch IP address is 172.20.20.85 and your PC or laptop IP address is 172.20.20.84, both devices are in the same network.
 - If your switch IP address is 172.20.20.85 and your PC or laptop IP address is 10.0.0.2, the devices are in different networks and cannot communicate directly.
- When the LED on the switch port connected to the PC or laptop is green, reenter the switch IP address in a web browser to display the Device Manager. When Device Manager appears, you can continue with the switch configuration.



Configuring the Switch with the CLI-Based Setup Program

This appendix provides a command-line interface (CLI)-based setup procedure for a switch. For information about setting up the switch by using Express Setup, see [Running Express Setup, page 97](#).

Before connecting the switch to a power source, review the safety warnings in [Warnings, page 29](#).

For installation procedures, see [Switch Installation, page 29](#).

Accessing the CLI Through the Console Port

You can enter Cisco IOS commands and parameters through the CLI. Use one of these options to access the CLI:

- [RJ-45 Console Port, page 102](#)
- [USB Mini-Type B Console Port, page 103](#)

Removing the USB Mini-Type B Console Port Cover

To remove the cover from the USB mini-type B console port:

1. Use a Phillips screwdriver to loosen the captive screw on the USB mini-type B console port cover. See [Figure 57 on page 102](#).
2. Remove the cover.

Figure 57 Removing the USB Mini-Type B Console Port Cover

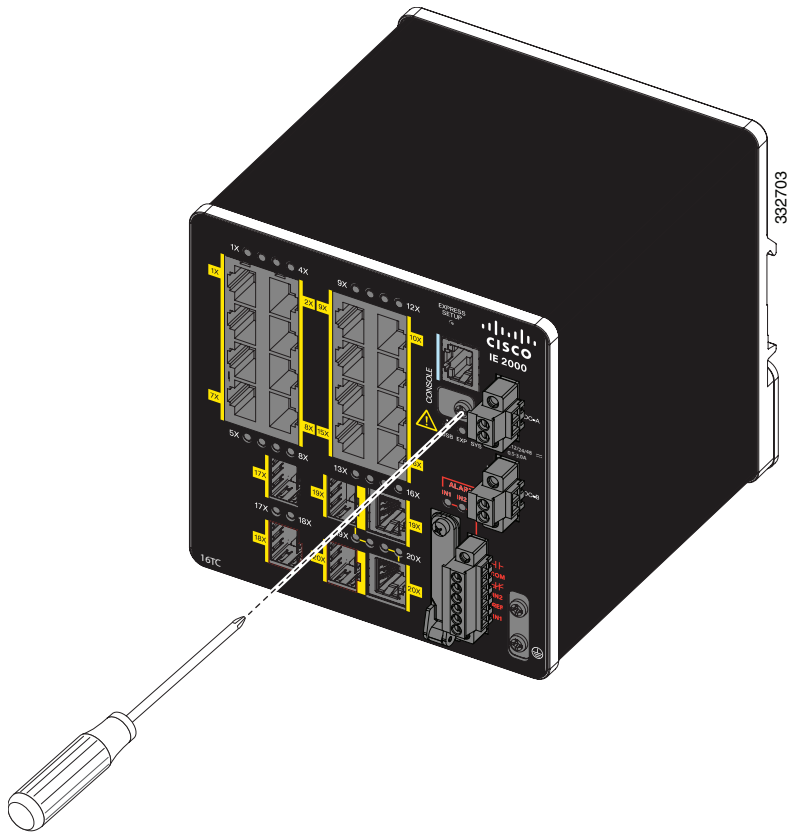

RJ-45 Console Port

1. Connect the RJ-45-to-DB-9 adapter cable to the 9-pin serial port on the PC. Connect the other end of the cable to the switch console port.
2. Start the terminal-emulation program on the PC or the terminal. The program, frequently a PC application such as HyperTerminal or ProcommPlus, makes communication between the switch and your PC or terminal possible.

Figure 58 Connecting the Console Cable

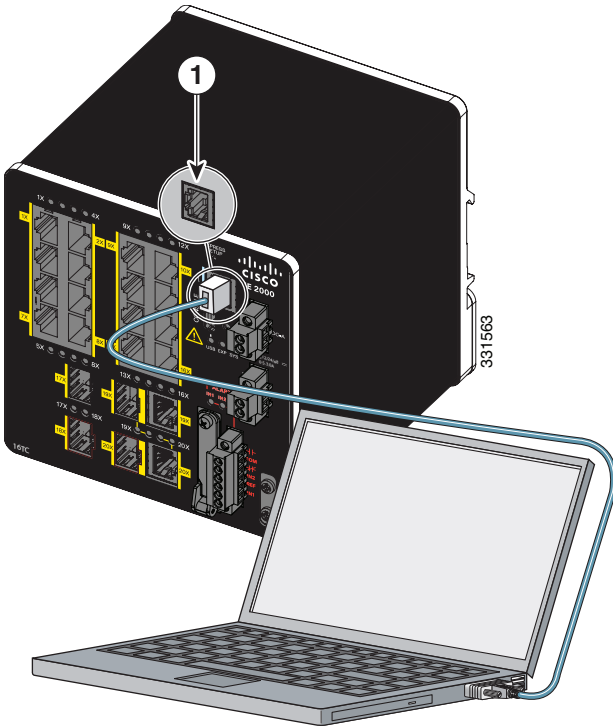

- 1 RJ-45 console port
- 2 Console cable (RJ-45-to-DB-9 adapter cable)

3. Configure the baud rate and character format of the PC or terminal to match the console port characteristics:

- 9600 baud
- 8 data bits
- 1 stop bit
- No parity
- None (flow control)

4. Connect power to the switch as described in [Connecting to Power, page 39](#).

The PC or terminal displays the bootloader sequence.

5. Press **Enter** to display the setup prompt.

6. Follow the steps in [Completing the Setup Program, page 106](#).

USB Mini-Type B Console Port

1. If you are connecting the switch USB-mini console port to a Windows-based PC for the first time, install a USB driver. See [Installing the Cisco Microsoft Windows XP, 2000, Vista, 7, 8, and 10 USB Device Driver, page 105](#) for more information.

Figure 59 Connecting the USB-Mini Console Cable

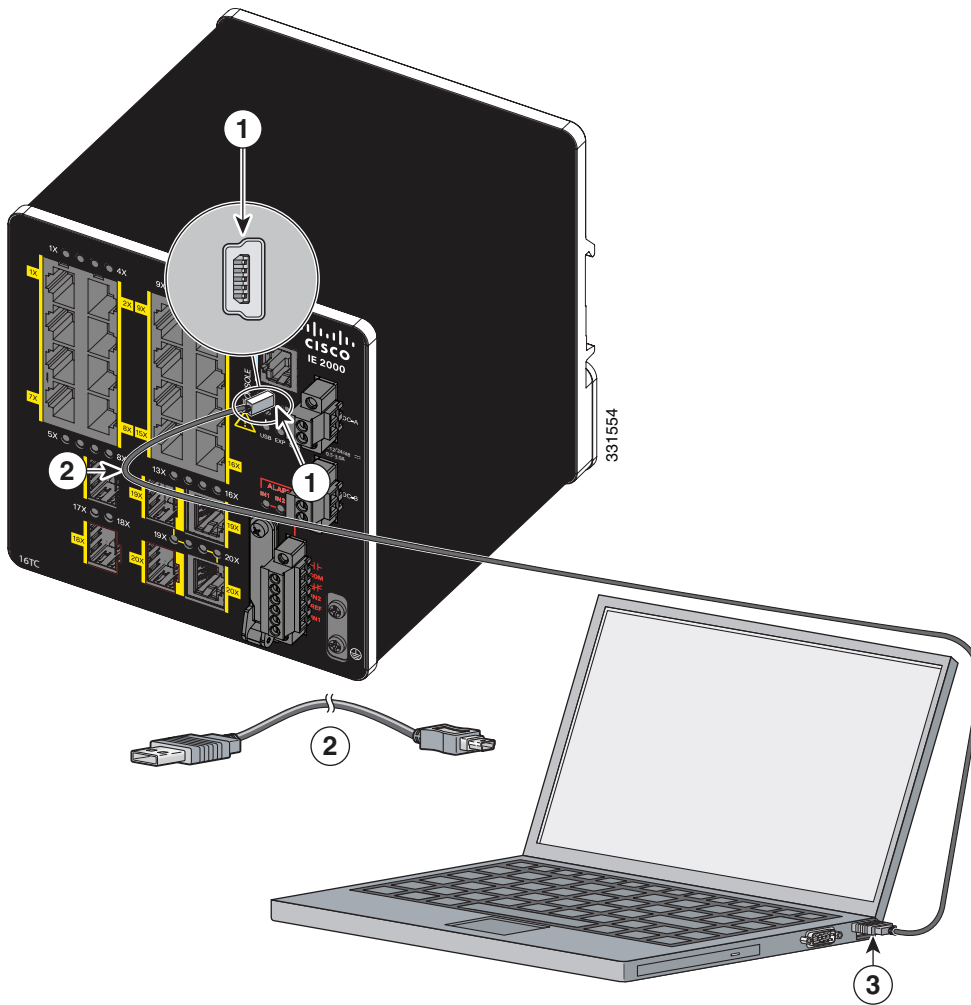

- 1 USB-mini console port 3 USB port on the PC
- 2 USB cable

2. Connect an USB cable to the PC USB port, and connect the other end of the cable to the switch mini-B (5-pin-connector) USB-mini console port. See [Figure 59](#).

3. Identify the COM port assigned to the USB-mini console port:

a. Choose **Start > Control Panel > Systems**.

b. Click the **Hardware** tab and choose **Device Manager**. Expand the **Ports** section. The assigned COM port appears in parenthesis at the end of the line with this entry: Cisco USB System Management Console.

4. Start the terminal-emulation program on the PC or the terminal.

The program, frequently a PC application such as HyperTerminal or ProcommPlus, makes communication possible between the switch and your PC or terminal.

5. Configure the COM port.

6. Configure the baud rate and character format of the PC or terminal to match the console port characteristics:

-
- 9600 baud
 - 8 data bits
 - 1 stop bit
 - No parity
 - None (flow control)
7. Connect power to the switch as described in [Connecting to Power, page 39](#).
The PC or terminal displays the bootloader sequence.
 8. Press **Enter** to display the setup prompt.
 9. Follow the steps in [Completing the Setup Program, page 106](#).

Installing the Cisco Microsoft Windows XP, 2000, Vista, 7, 8, and 10 USB Device Driver

A USB device driver must be installed the first time a Microsoft Windows-based PC is connected to the USB console port on the switch. Use this procedure to install the USB driver on Windows XP, Windows 2000, Windows Vista, Windows 7, Windows 8, and Windows 10.

1. Obtain the file `Cisco_usbconsole_driver_3_1.zip` from the Cisco.com website <https://software.cisco.com/download/release.html?mdfid=282979369&softwareid=282855122&release=3.1>

The file details are as follows:

- Description: `Cisco_usbconsole_driver_3_1.zip`
 - Release: 3.1
 - Release Date: 27/Nov/2014
 - File Name: `Cisco_usbconsole_driver_3_1.zip`
 - Size: 14.35 MB (15045453 bytes)
 - MD5 Checksum: `eff2e955edcdc70209e6f9c8f6bd59cd`
2. Unzip the file and install the corresponding exe file.
 3. Navigate to the **Device Manager** window by performing a search in Windows for **Device Manager** and opening it.
 4. Connect the USB cable from the Windows PC to the Cisco switch.
 5. From the **Device Manager** page, expand **Ports (COM & LPT)**. Select **USB Serial Port**. Right-click and select **Update Driver Software ...**
 6. In the Update Driver Software window, select **Browse my computer for driver software**. Then choose **Let me pick from a list of device drivers on my computer** and click **Next**.
 7. Enable **Show compatible hardware** and choose **Cisco Serial** as the model. Click **Next**.
After the update is completed, Windows displays **Windows has successfully updated your driver software**.
 8. Click **Close**.

Uninstalling the Cisco Microsoft Windows XP, 2000, Vista, 7, 8, and 10 USB Driver

Note: Disconnect the switch console terminal before uninstalling the driver.

1. Run setup.exe for Windows 32-bit or setup(x64).exe for Windows-64bit.
2. Click **Next**.
3. When the InstallShield Wizard for Cisco Virtual Com appears, click **Next**.
4. When the Program Maintenance window appears, select the **Remove** radio button.
5. Click **Next**.
6. When the Remove the Program window appears, click **Remove**.

If a User Account Control warning appears, click **Allow - I trust this program to proceed**.

7. When the InstallShield Wizard Completed window appears, click **Finish**.

Entering the Initial Configuration Information

To set up the switch, you must complete the setup program, which runs automatically after the switch is powered on. Assign an IP address and any other configuration information necessary for the switch to communicate with the local routers and the Internet. This information is also required if you plan to use Device Manager or Cisco Network Assistant to configure and manage the switch.

IP Settings

Gather this information from your network administrator before completing the setup program:

- Switch IP address
- Subnet mask (IP netmask)
- Default gateway (router)
- Enable secret password
- Enable password
- Telnet password

Completing the Setup Program

To complete the setup program and to create an initial configuration for the switch:

1. Enter **Yes** at these two prompts:

```
Would you like to enter the initial configuration dialog? [yes/no]: yes
```

```
At any point you may enter a question mark '?' for help.  
Use ctrl-c to abort configuration dialog at any prompt.  
Default settings are in square brackets '[]'.
```

```
Basic management setup configures only enough connectivity  
for management of the system, extended setup will ask you  
to configure each interface on the system.
```

```
Would you like to enter basic management setup? [yes/no]: yes
```

2. Enter a hostname for the switch, and press **Return.**

On a command switch, the hostname is limited to 28 characters; on a member switch, it is limited to 31 characters. Do not use *-n*, where *n* is a number, as the last character in a hostname for any switch.

```
Enter host name [Switch]: host_name
```

3. Enter an enable secret password, and press **Return.**

The password can be from 1 to 25 alphanumeric characters, can start with a number, is case sensitive, allows spaces, but ignores leading spaces. The secret password is encrypted, and the enable password is in plain text.

```
Enter enable secret: secret_password
```

4. Enter an enable password, and press **Return.**

```
Enter enable password: enable_password
```

5. Enter a virtual terminal (Telnet) password, and press **Return.**

The password can be from 1 to 25 alphanumeric characters, is case sensitive, allows spaces, but ignores leading spaces.

```
Enter virtual terminal password: terminal_password
```

6. (Optional) Configure Simple Network Management Protocol (SNMP) by responding to the prompts.

You can also configure SNMP later through the CLI, Device Manager, or the Cisco Network Assistant application.

To configure SNMP later, enter **no**.

```
Configure SNMP Network Management? [no]: no
```

7. Enter the interface name (physical interface or VLAN name) of the interface that connects to the management network, and press **Return.**

For this release, always use **vlan1** as that interface.

```
Enter interface name used to connect to the  
management network from the above interface summary: vlan1
```

8. Configure the interface by entering the switch IP address and subnet mask and pressing **Return.**

The IP address and subnet masks shown here are examples.

```
Configuring interface vlan1:  
Configure IP on this interface? [yes]: yes  
IP address for this interface: 10.4.120.106  
Subnet mask for this interface [255.0.0.0]: 255.0.0.0
```

9. Enter **Y to configure the switch as the cluster command switch. Enter **N** to configure it as a member switch or as a standalone switch.**

If you enter **N**, the switch appears as a candidate switch in the Cisco Network Assistant GUI. You can configure the switch as a command switch later through the CLI, Device Manager, or the Cisco Network Assistant application.

To configure it later, enter **no**.

```
Would you like to enable as a cluster command switch? [yes/no]: no
```

You have now completed the initial configuration of the switch, and the switch displays its initial configuration script:

The following configuration command script was created:

```
hostname Switch
enable secret 5 $1$ZQRe$DPuLYXyQLm77v/a4Bmu6Y.
enable password cisco
line vty 0 15
password cisco
no snmp-server
!
!
interface Vlan1
no shutdown
ip address 10.4.120.106 255.0.0.0
!
interface FastEthernet1/1
!
interface FastEthernet1/2
!
interface FastEthernet1/3
!
...(output abbreviated)
!
interface GigabitEthernet1/1
!
interface GigabitEthernet1/2
!
end
```

These choices appear:

- [0] Go to the IOS command prompt without saving this config.
- [1] Return back to the setup without saving this config.
- [2] Save this configuration to nvram and exit.

If you want to save the configuration and use it the next time the switch reboots, save it in NVRAM by selecting option 2.

Enter your selection [2]:**2**

10. Make your selection, and press **Return.**

After you complete the setup program, the switch can run the default configuration that you created. To change this configuration or perform other management tasks, use one of these tools:

- Command-line interface (CLI)
- Cisco Network Assistant (for one or more switches)

To use the CLI, enter commands at the Switch> prompt through the console port by using a terminal emulation program or through the network by using Telnet.

For configuration information, see the *Cisco IE 2000 Switch Software Configuration Guide* or the *Cisco IE 2000 Switch Command Reference*.

To use the Cisco Network Assistant, see the *Getting Started with Cisco Network Assistant* guide on Cisco.com.